

PROJECT DESCRIPTION:

CONDUCT PERIODIC MAINTENANCE/REPAIR WORK ON EXISTING RESIDENTIAL DOCK ON LAKE WASHINGTON. WORN WOODEN DECKING TO BE REPLACED WITH THRUFLOW GRATED DECKING. WORN DOCK FRAMING ELEMENTS TO BE REPLACED AS SHOWN.

PROPERTY OWNER:

NANCY MULLEN
5233 82ND AVE. SE
MERCER ISLAND, WA 98040

CONTACT:

IRWIN LAND USE CONSULTING, LLC
P.O. BOX 1715
BELLINGHAM, WA 98227
(360) 410-6745
irwinlanduse@gmail.com

LEGAL DESCRIPTION:

CARRS LAKE SIDE ADD TRACT B MERCER ISLAND SHORT PLAT NO 80-06-08 REC NO 8007039004 SD TRACT DAF-BEG NXN OF WLY MGN 82ND SE & NLY LN OF SLY 10 FT OF LOT 7 AS MEAS AT R/A TH N 89-52-08 W ALG SD NLY LN 214.95 FT TO TPOB TH N 43-06-37 E 87.56 FT TH ON CRV RGT RAD 133.10 FT DIS 39.67 FT TH N 60-11-12 E 21.58 FT TH ON CRV RGT RAD 74.03 FT DIS 35.95 FT TH N 88-00-25 E 23.22 FT TO SD WLY MGN 82ND SE TH NLY ALG SD WLY MGN TO NLY LN SD LOT 10 TH N 89-45-23 W ALG SD NLY LN TO NLY LN SLY 10 FT OF LOT 7 TH S 89-52-08 E TO TPOB & 2ND CL SH LDS ADJ

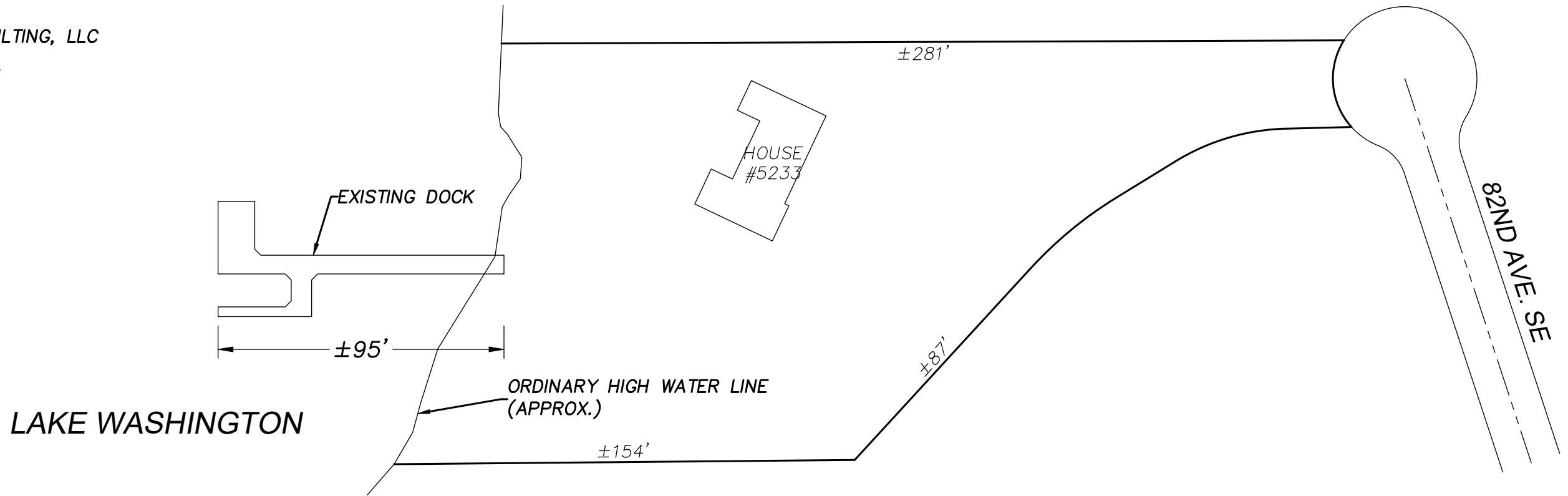
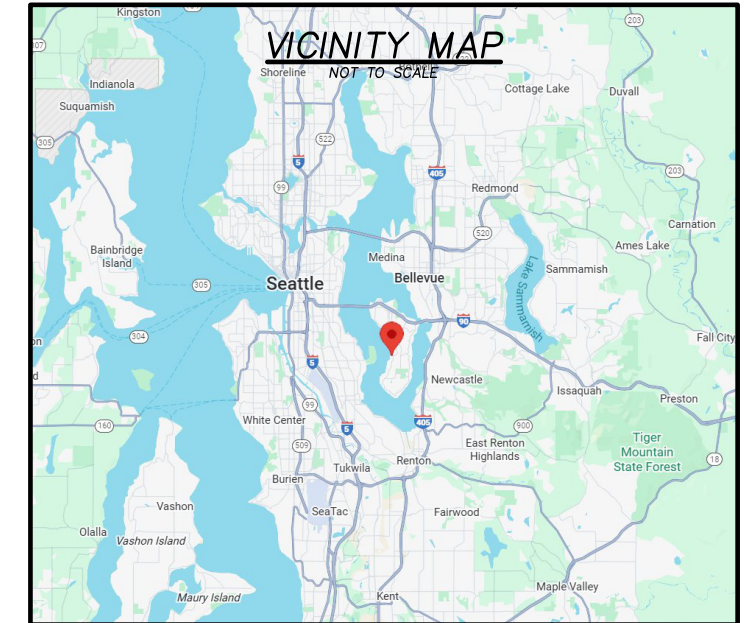
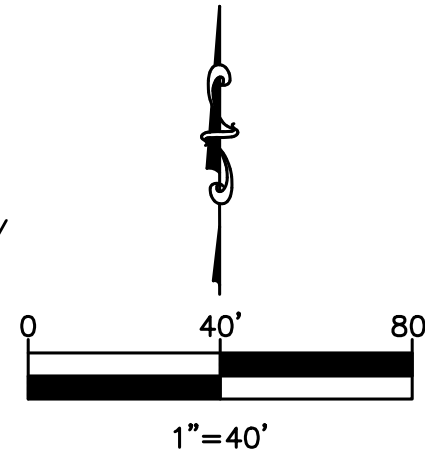

*LOT BOUNDARIES AND BUILDING LOCATIONS PER ROS AFN 198007039004 AND KING COUNTY ASSESSOR'S GIS DATA. DOCK DIMENSIONS, PROJECT DESCRIPTION AND WATER DEPTHS PER LAKESIDE CONSTRUCTION.



LAKESIDE CONSTRUCTION
P.O. BOX 525
ISSAQUAH, WA 98027
(206) 850-0250
sales@lakesideseattle.com

REV	DATE	BY	DESCRIPTION

MULLEN
DOCK REPAIR
5233 82ND AVE. SE
MERCER ISLAND, WA 98040

PROJECT NUMBER:	2534
PARCEL NUMBER:	1410300040
ISSUE DATE:	1/30/2026

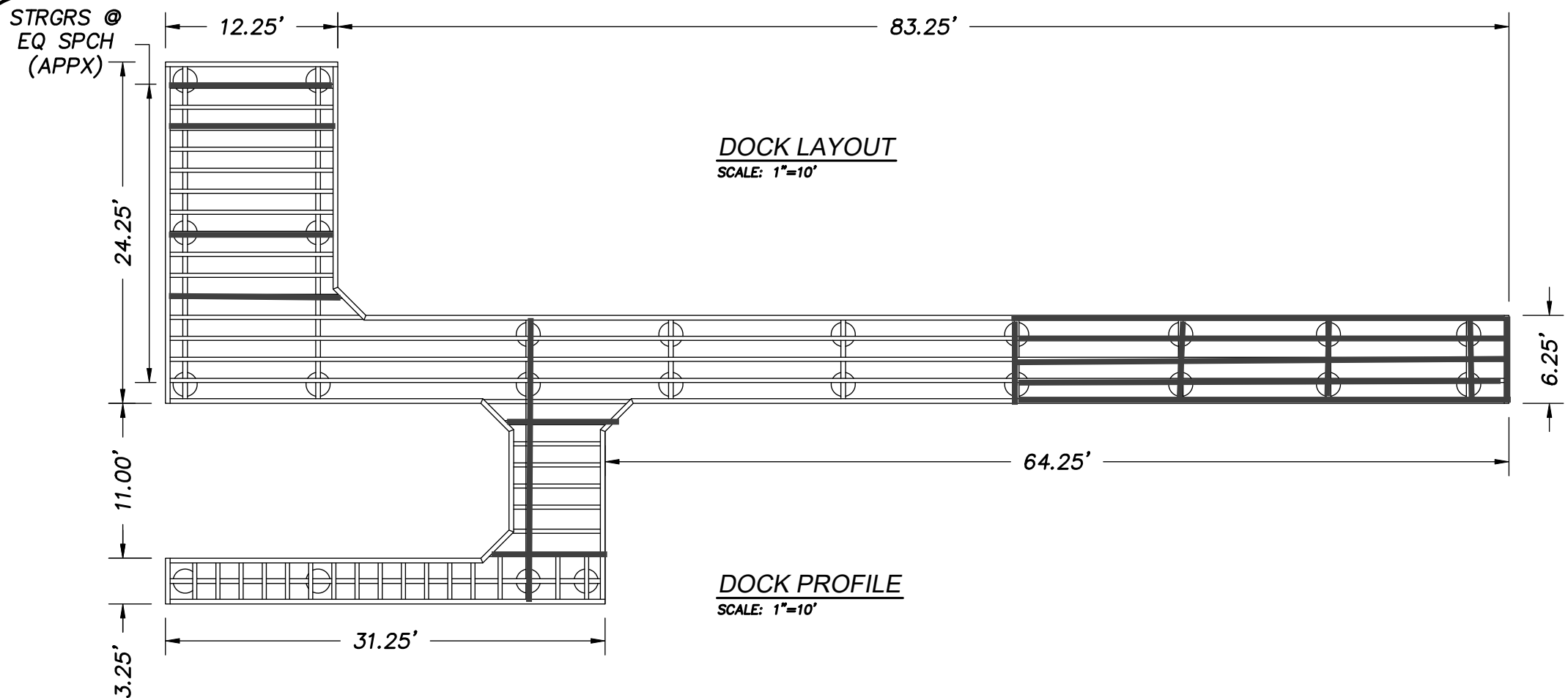

PROJECT DETAILS:

- PERCENTAGE OF DOCK SURFACING TO BE REPLACED = 100%
- REPLACEMENT DECKING TO BE THRUFLOW GRATED PANELS. SEE ATTACHED MANUFACTURER'S SPECIFICATIONS INDICATING 43% (MIN.) LIGHT PERMEABILITY.
- FRAMING MEMBERS TO BE REPLACED SHOWN IN BOLD LINES.
- NOTE: REPLACEMENT FRAMING MEMBERS TO BE ACZA TREATED FIR (SEE ATTACHED WHITE PAPER/ PRODUCT ANALYSIS FROM WDFW REGARDING ACZA TREATMENT).

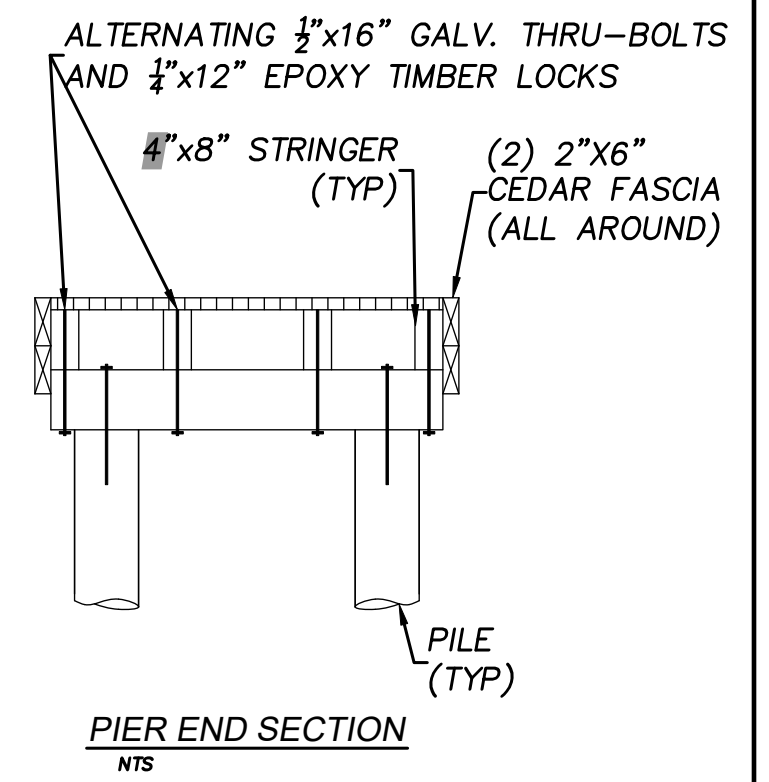
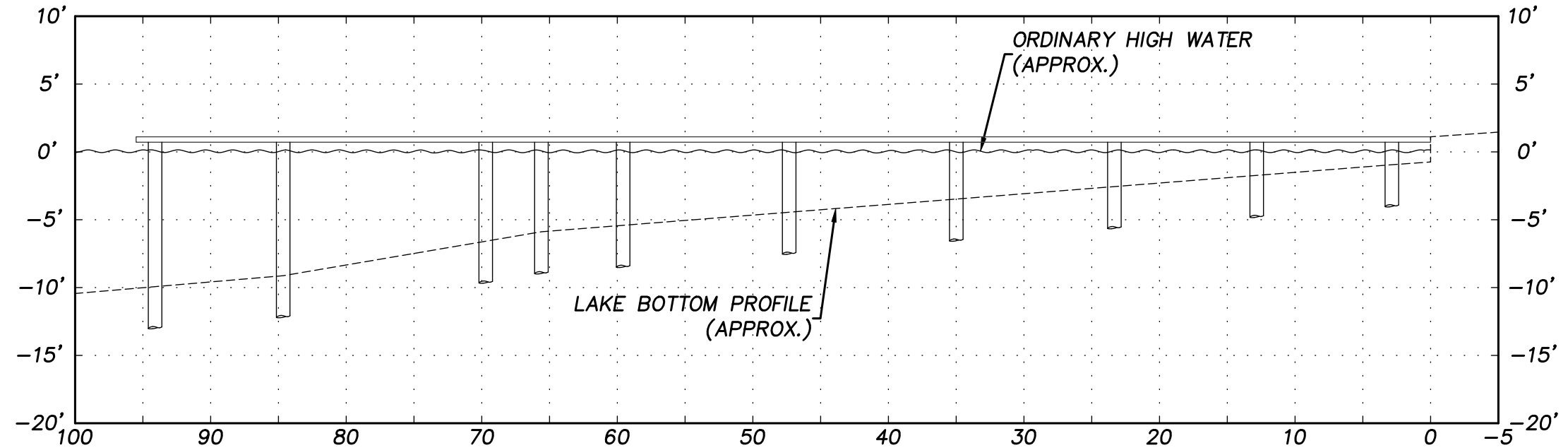

LAKESIDE CONSTRUCTION
P.O. BOX 525
ISSAQUAH, WA 98027
(206) 850-0250
sales@lakesideseattle.com

REV	DATE	BY	DESCRIPTION

MULLEN
DOCK REPAIR
5233 82ND AVE. SE
MERCER ISLAND, WA 98040

PROJECT NUMBER:	2534
PARCEL NUMBER:	1410300040
ISSUE DATE:	1/30/2026