

PROJECT DESCRIPTION:

CONDUCT PERIODIC MAINTENANCE/REPAIR WORK ON EXISTING RESIDENTIAL DOCK ON LAKE WASHINGTON. DOCK FRAMING TO BE REPLACED WITH ACZA TREATED FIR AS SHOWN – STRINGERS TO BE 4" X 8", JOISTS/PILE CAPS TO BE 6" X 8". WOODEN DECKING TO BE REPLACED WITH THRUFLOW GRATED PANELS. PILES TO BE SLEEVED AS SHOWN WITH HDPE TUBES. ALL WORK TO BE DONE IN EXISTING DOCK FOOTPRINT.

PROPERTY OWNER:

YEI (ALBERT) SUN
2451 60TH AVE SW
MERCER ISLAND, WA 98040

CONTACT:

IRWIN LAND USE CONSULTING, LLC
P.O. BOX 1715
BELLINGHAM, WA 98227
(360) 410-6745
irwinlanduse@gmail.com

LEGAL DESCRIPTION:

CENTRAL ADD TO EAST SEATTLE LOT "B" MERCER ISLAND SHORT PLAT NO M.I. 96-021 REC NO. 9806189005 SD SHORT PLAT DAF -- ALL LOTS 6-7-8 AND 17-18-19 IN BLOCK 2 AND ALL LOTS 8-9-10&11 IN BLOCK 1 OF CENTRAL ADDITION TO EAST SEATTLE TGW THAT POR OF LOT 7 IN BLOCK 1 LY SOUTH OF EXTD NORTH LN OF LOTS 8 & 17 IN BLOCK 2 LESS POR OF SD LOT 7 BLOCK 1 INCL 2ND CL SH LDS – ALSO THAT POR OF LOT 12 BLOCK 1 LY NORTH OF EXTD SOUTH LN OF LOTS 6 & 19 IN BLOCK 2-TGW POR OF ALLEY BTWN SD PORS OF BLOCK 1 & 2 LY SOUTH OF EXTD NORTH LN OF LOT 8 OF SD BLK 2 AND NORTH OF EXTD SOUTH LN OF LOT 6 OF SD BLOCK 2-TGW ALL 2ND CL SH LDS LY IN FRONT OF LOTS 8-9-10 & 11 AND NORTH 11.05 FT OF LOT 12 BLOCK 1 OF SD PLAT

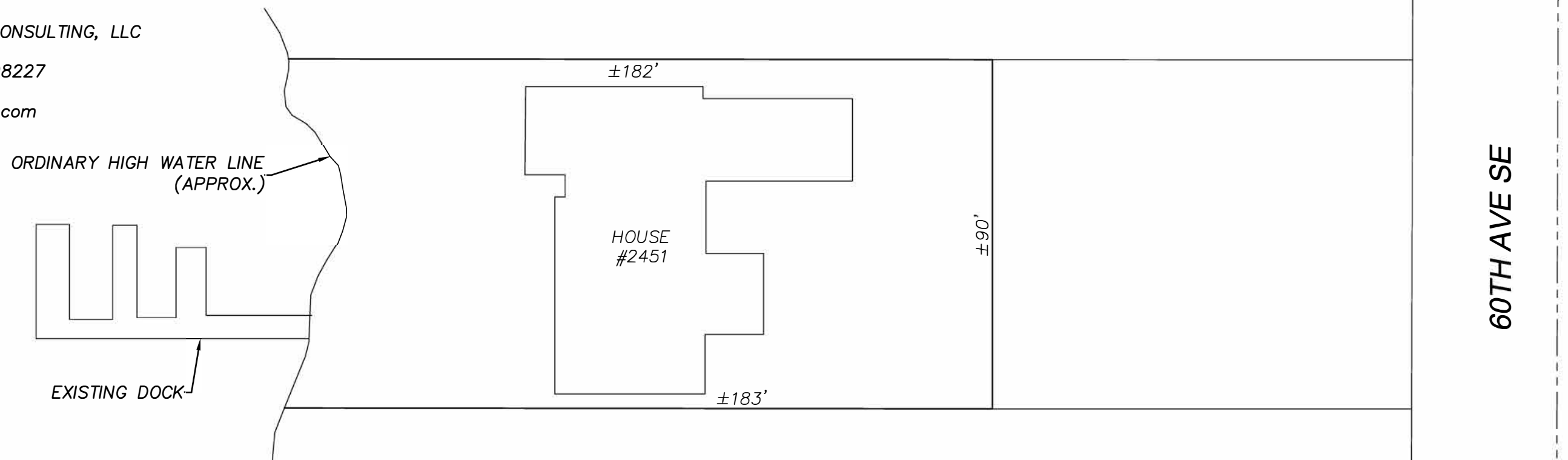
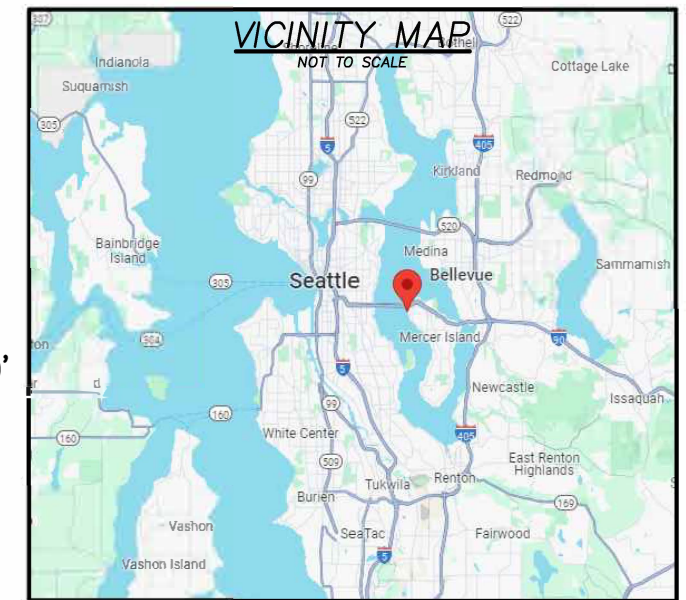
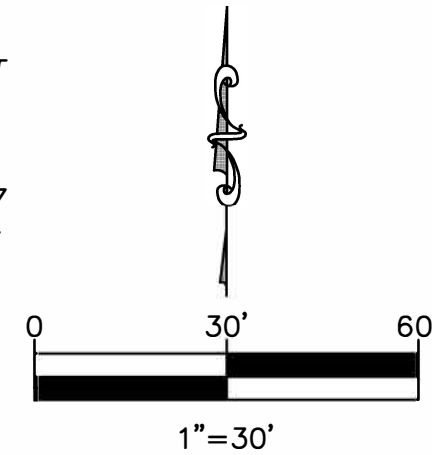

LAKE WASHINGTON

*LOT BOUNDARIES AND BUILDING LOCATIONS PER SURVEY AFN 9806189005 AND KING COUNTY ASSESSOR'S DATA. DOCK DIMENSIONS, PROJECT DESCRIPTION AND WATER DEPTHS PER LAKESIDE CONSTRUCTION.



LAKESIDE CONSTRUCTION
P.O. BOX 525
ISSAQUAH, WA 98027
(206) 850-0250
sales@lakesideseattle.com

REV	DATE	BY	DESCRIPTION

SUN
DOCK REPAIR
2451 60TH AVE SW
MERCER ISLAND, WA 98040

PROJECT NUMBER:	2415
PARCEL NUMBER:	1483300036
ISSUE DATE:	10/2/2024

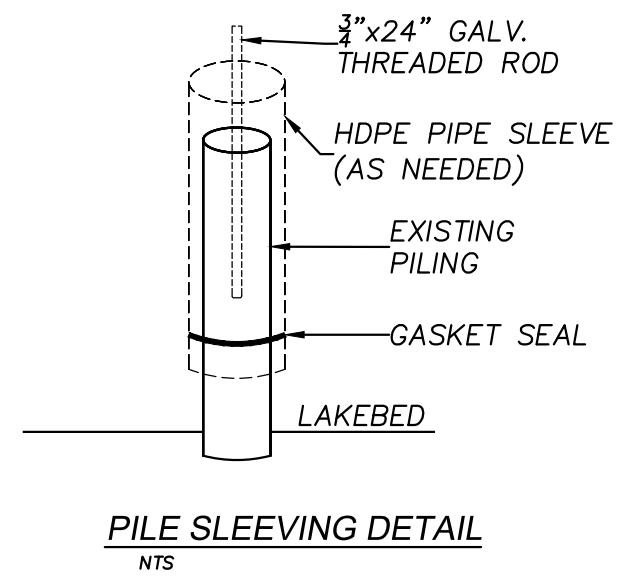
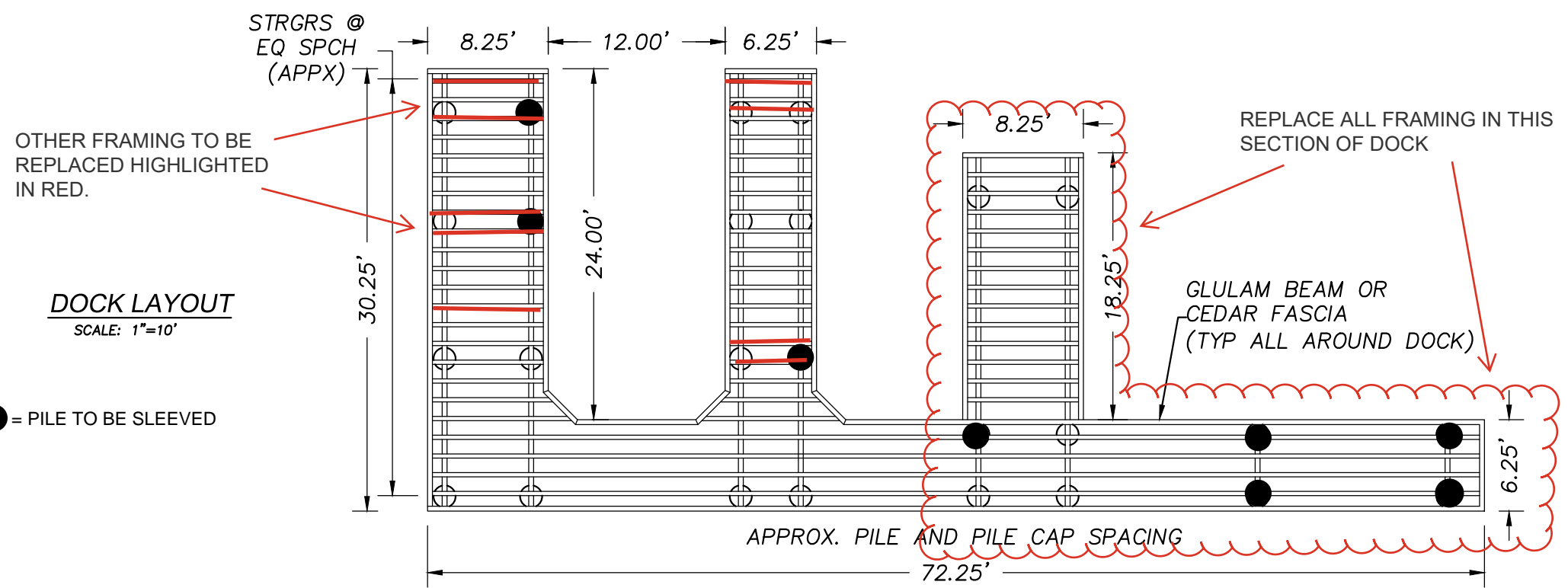

DOCK LAYOUT
SCALE: 1"=10'

PILE SLEEVING DETAIL
NTS

DOCK PROFILE
SCALE: 1"=10'

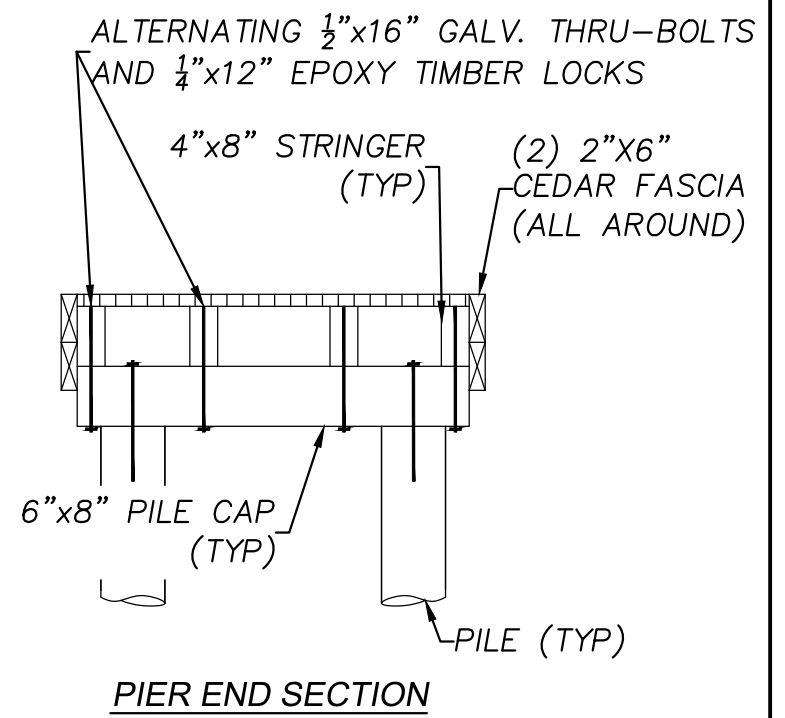
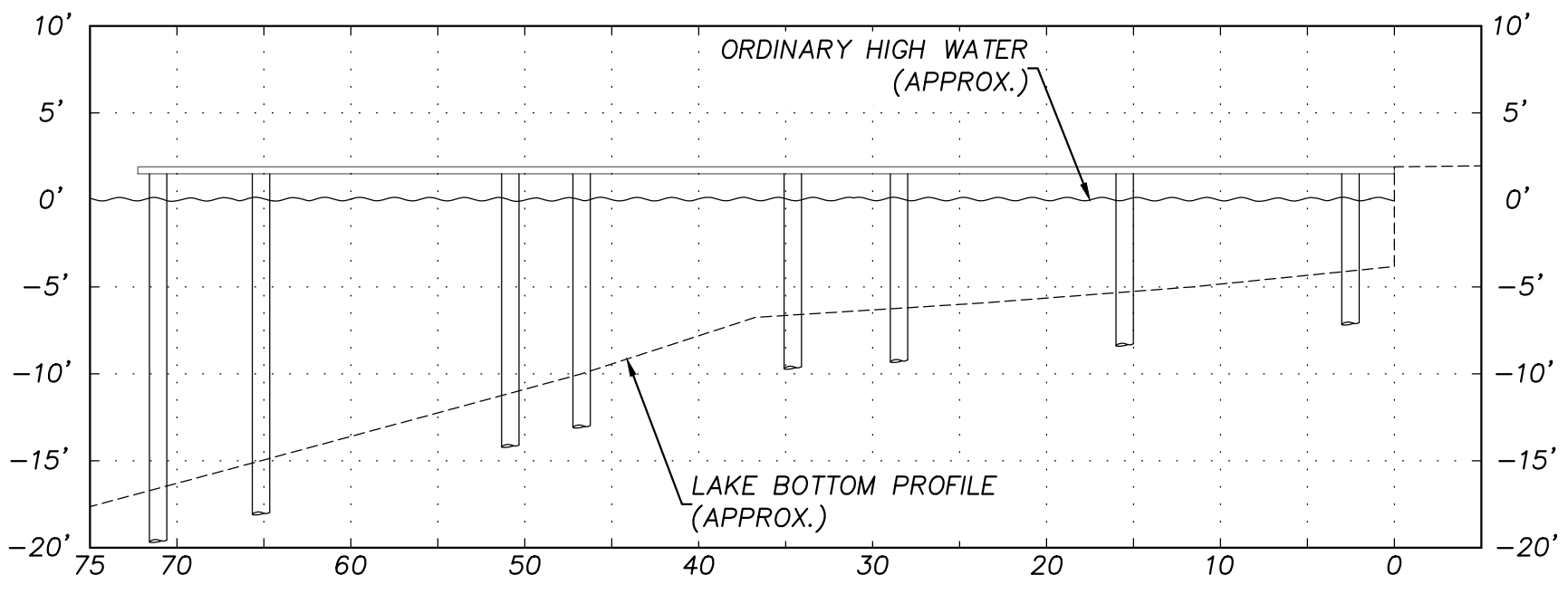

PIER END SECTION



LAKESIDE CONSTRUCTION
P.O. BOX 525
ISSAQUAH, WA 98027
(206) 850-0250
sales@lakesideseattle.com

REV	DATE	BY	DESCRIPTION

SUN
DOCK REPAIR
2451 60TH AVE SW
MERCER ISLAND, WA 98040

PROJECT NUMBER:	2415
PARCEL NUMBER:	1483300036
ISSUE DATE:	10/2/2024