

# CITY OF MERCER ISLAND

## COMMUNITY PLANNING & DEVELOPMENT

9611 SE 36TH STREET | MERCER ISLAND, WA 98040

PHONE: 206.275.7605 | [www.mercerisland.gov](http://www.mercerisland.gov)

Inspection Requests: Online: [www.MyBuildingPermit.com](http://www.MyBuildingPermit.com) VM: 206.275.7730



## SECTION A: SMALL PROJECT STORMWATER SITE PLAN/REPORT

### Narrative and Plan Submittal

**Instructions:** This is a template for a simplified Stormwater Report. This form or an equivalent must accompany your Building Permit Application if the answer is "Yes" to each statement below. If "No" is the answer to one or more of the statements below, a full Drainage Report is required and the project does not qualify for use of the Small Project Stormwater Site Plan/Report template.

Select "yes" or "no" for each statement below. Answer "yes" if the statement accurately describes your project.

Yes	No	Statement
		This project disturbs less than 1 acre and is not part of a larger common plan of development.
		This project converts less than 3/4 acre to lawn or landscape areas.
		This project will create, add, or replace (in any combination) 2,000 square feet or greater, but less than 5,000 square feet, of new plus replaced hard surface <b>OR</b> will have a land disturbing activity of 7,000 square feet or greater <b>OR</b> will result in a net increase of impervious surface of 500 square feet or greater.
		This project will not adversely impact a wetland, stream, water of the state, or change a natural drainage course.

### Basic Project Information

Project Name: \_\_\_\_\_

Site Address: \_\_\_\_\_

Total Lot Size: \_\_\_\_\_

Total Proposed Area to be Disturbed (including stockpile area): \_\_\_\_\_ sq ft

Total Volume of Proposed Cut and Fill: \_\_\_\_\_ sq ft

Total Proposed New Hard Surface Area: \_\_\_\_\_ sq ft

Total Proposed Replaced Hard Surface Area: \_\_\_\_\_ sq ft

Total Proposed Converted Pervious Surface Area  
(Native vegetation to lawn or landscape): \_\_\_\_\_ sq ft

Net Increase in Impervious Surface: \_\_\_\_\_ sq ft



# CITY OF MERCER ISLAND

## SECTION A: SMALL PROJECT STORMWATER SITE PLAN/REPORT

### Minimum Requirement #1 : Preparation of Stormwater Site Plan

Written Project Description:

Calculate new or replaced areas by surface type:

Lawn or Landscape Areas: _____ sq ft	Roof Area: _____ sq ft
Other Hard Surface Areas:	
Driveway: _____ sq ft    Patio: _____ sq ft    Sidewalk: _____ sq ft	
Parking Lot: _____ sq ft    Other: _____ sq ft	

Attach Drainage Plan

Drainage Plan shall include the following:

- Scaled drawing with slopes, lot lines, any public-right-of-way and any easements, location of each on-site stormwater management BMP selected above and the areas served by them, buildings, roads, parking lots, driveways, landscape features, and areas of disturbed soils to be amended.
- The scaled drawing must be suitable to serve as a recordable document that will be attached to the property deed for each lot that includes on-site BMPs. Document submittal must follow the “Standard Formatting Requirements for Recording Documents” per King County: [www.kingcounty.gov/depts/records-licensing/recorders-office/recording-documents.aspx](http://www.kingcounty.gov/depts/records-licensing/recorders-office/recording-documents.aspx)
- Identify design details and maintenance instructions for each on-site BMP, and attach them to this Small Project Stormwater Site Plan/Report.



# CITY OF MERCER ISLAND

## SECTION A: SMALL PROJECT STORMWATER SITE PLAN/REPORT

### Minimum Requirement #2 : Construction Stormwater Pollution Prevention

- Complete Section B of this submittal package: Construction Stormwater Pollution Prevention Plan Narrative (SWPPP)
- Attach construction SWPPP

### Minimum Requirement #3 : Source Control of Pollution

This section contains practices and procedures to reduce the release of pollutants. Provide a description of all known, available and reasonable source control BMPs that will be, or are anticipated to be, used at this location to prevent stormwater from coming into contact with pollutants. Additional BMPs are found in Volume IV of the 2014 Stormwater Management Manual for Western Washington (SWMMWW).

Check the BMPs you will use:

- BMP S411 for Landscaping and Lawn/ Vegetation Management  
Operational practices for sites with landscaping
- BMP S421 for Parking and Storage of Vehicles.  
Public and commercial parking lots can be sources of suspended solids, metals, or toxic hydrocarbons such oils and greases.
- BMP S433 for Pools, Spas, Hot Tubs, Fountains  
Discharge from pools, hot tubs, and fountains can degrade ambient water quality. Routine maintenance activities generate a variety of wastes. Direct disposal of these waters to drainage system and waters of the state are not permitted without prior treatment and approval.
- Other BMPs found in Volume IV of SWMMWW applicable to project:

- No source control BMPs are applicable for this project.



# CITY OF MERCER ISLAND

## SECTION A: SMALL PROJECT STORMWATER SITE PLAN/REPORT

### Minimum Requirement #4 : Preservation of Natural Drainage Systems

Natural drainage patterns shall be maintained and discharges from the project site shall occur at the natural location, to the maximum extent practicable. All outfalls require energy dissipation.

Choose the option below that best describes your project:

This site has existing drainage systems or outfalls. These items are shown on the Drainage Plan. Include the following items on the Drainage Plan:

- Pipe invert elevations, slopes, cover, and material
- Locations, grades, and direction of flow in ditches and swales, culverts, and pipes

Describe how these systems will be preserved:

This site does not have any existing drainage systems or outfalls.

Additional Comments:



# CITY OF MERCER ISLAND

## SECTION A: SMALL PROJECT STORMWATER SITE PLAN/REPORT

### Minimum Requirement #5 : On-site Stormwater Management

All projects meeting the thresholds for this Small Project Stormwater Report shall employ on-site stormwater management BMPs (See Small Project Stormwater Requirements Tip Sheet) to infiltrate, disperse, and retain stormwater runoff on-site to the extent feasible without causing flooding or erosion impacts.

### List #1

For each category select the *first* feasible item on the list below. Document your justification for each infeasible BMP in Section C of this submittal package.

Check one option for each category below:



### Lawn and Landscape Areas

- My project does not have *Lawn or Landscape* areas
- Post-construction soil quality and depth
- Post-construction soil quality and depth is infeasible (see Section C of this submittal package)



### Roofs

- My project does not have *Roof* areas
- 1. Full dispersion or downspout full infiltration
- 2. Rain garden or bioretention
- 3. Downspout dispersion system
- 4. Perforated stub-out connections
- 5. On-site detention system or fee-in-lieu of on-site detention authorized by the City Engineer (applicable if options #1-4 are infeasible and drainage from the site will be discharged to a storm or surface water system that includes a watercourse or there is a capacity constraint in the system)
- 6. No Roof BMP (applicable if options #1-4 are infeasible and on-site detention is not required)

Measured Infiltration Rate: \_\_\_\_\_ in/ hr

If #5 or #6 is selected, briefly describe why no Roof BMP is feasible (include detailed information in Section C of this submittal package):



# CITY OF MERCER ISLAND

## SECTION A: SMALL PROJECT STORMWATER SITE PLAN/REPORT

### Minimum Requirement #5 : On-site Stormwater Management (cont.)



#### Other Hard Surfaces (such as driveway, sidewalk, parking lot, patio, etc.)

- My project does not have *Other Hard Surface* areas
- 1. Full dispersion
- 2. Permeable pavement, rain gardens, or bioretention
- 3. Sheet flow dispersion or concentrated flow dispersion
- 4. On-site detention system or fee-in-lieu of on-site detention authorized by the City Engineer (applicable if options #1-3 are infeasible and drainage from the site will be discharged to a storm or surface water system that includes a watercourse or there is a capacity constraint in the system)
- 5. No Other Hard Surface BMP (applicable if options #1-3 are infeasible and on-site detention is not required)

Measured Infiltration Rate: \_\_\_\_\_ in/ hr

If #4 or #5 is selected, briefly describe why no Other Hard Surface BMP is feasible (include detailed information in Section C of this submittal package):

### Flow Control Exempt List

Proceed with this list if your project discharges directly to Lake Washington or if findings from a downstream analysis confirm that the downstream system is free of capacity constraints for a minimum of ¼ mile and a maximum of 1 mile.

For flow control exempt discharges, the BMPs listed below for Roofs and Other Hard Surfaces do not need to be evaluated in priority order. You can select any BMP from the lists provided below and do not need to document infeasibility in Section C of this submittal package.

Check one option for each category below:



#### Lawn and Landscape Areas

- My project does not have *Lawn or Landscape* areas
- Post-construction soil quality and depth



# CITY OF MERCER ISLAND

## SECTION A: SMALL PROJECT STORMWATER SITE PLAN/REPORT

### Minimum Requirement #5 : On-site Stormwater Management (cont.)



#### Roofs

- My project does not have *Roof* areas
- Downspout full infiltration
- Downspout dispersion system
- Perforated stub-out connections
- Each item above is infeasible

If “Each item above is infeasible” is selected, briefly describe why no Roof BMP is feasible:



#### Other Hard Surfaces (such as driveway, sidewalk, parking lot, patio, etc.)

- My project does not have *Other Hard Surface* areas
- Sheet flow dispersion
- Concentrated flow dispersion
- Each item above is infeasible

If “Each item above is infeasible” is selected, briefly describe why no Other Hard Surface BMP is feasible:



# CITY OF MERCER ISLAND

## SECTION B: SMALL PROJECT CONSTRUCTION SWPPP NARRATIVE

### Instructions

This is a template for a simplified Construction Stormwater Pollution Prevention Plan ("Construction SWPPP"). If "No" is the answer to one or more of the statements on the first page of Section A of this submittal package, then a full Construction SWPPP is required and the project does not qualify for the use of the Small Project Construction SWPPP Narrative template. If the project is less than the thresholds on the first page of Section A of this submittal package, then Minimum Requirement #2 still applies, but this section (Section B) or a full construction SWPPP is not required. You should include your Construction SWPPP in your contract with your builder. A copy of the Construction SWPPP must be located at the construction site or within reasonable access to the site for construction and inspection personnel at all times.

### General Information on the Existing Site and Project

Describe the following in the Project Narrative box below (attach additional pages if necessary):

- Nature and purpose of the construction project
- Existing topography, vegetation, and drainage, and building structures
- Adjacent areas, including streams, lakes, wetlands, residential areas, and roads that might be affected by the construction project
- How upstream drainage areas may affect the site
- Downstream drainage leading from the site to the receiving body of water
- Areas on or adjacent to the site that are classified as critical areas
- Critical areas that receive runoff from the site up to one-quarter mile away
- Special requirements and provisions for working near or within critical areas
- Areas on the site that have potential erosion problems

Project Narrative:



# CITY OF MERCER ISLAND

## SECTION B: SMALL PROJECT CONSTRUCTION SWPPP NARRATIVE

### Construction SWPPP Drawings

Refer to the general Drawing Requirements in Stormwater Management Manual for Western Washington (SWMMWW) Volume I, Chapter 3.

### Vicinity Map

Provide a map with enough detail to identify the location of the construction site, adjacent roads, and receiving waters.

### Site Map

Include the following (where applicable):

- |  |   |
|--|---|
| <input type="checkbox"/> Legal description of the property boundaries or an illustration of property lines (including distances) on the drawings.          | <input type="checkbox"/> Final and interim grade contours as appropriate, drainage basins, and the direction of stormwater flow during and upon completion of construction. |
| <input type="checkbox"/> North arrow.  | <input type="checkbox"/> Areas of soil disturbance, including all areas affected by clearing, grading, and excavation.  |
| <input type="checkbox"/> Existing structures and roads.  | <input type="checkbox"/> Locations where stormwater will discharge to surface waters during and upon completion of construction.  |
| <input type="checkbox"/> Boundaries and identification of different soil types.  | <input type="checkbox"/> Existing unique or valuable vegetation and vegetation to be preserved.   |
| <input type="checkbox"/> Areas of potential erosion problems.  | <input type="checkbox"/> Cut-and-fill slopes indicating top and bottom of slope catch lines.  |
| <input type="checkbox"/> Any on-site and adjacent surface waters, critical areas, buffers, flood plain boundaries, and Shoreline Management boundaries.    | <input type="checkbox"/> Total cut-and-fill quantities and the method of disposal for excess material.  |
| <input type="checkbox"/> Existing contours and drainage basins and the direction of flow for the different drainage areas.                                 | <input type="checkbox"/> Stockpile; waste storage; and vehicle storage, maintenance, and washdown areas.  |
| <input type="checkbox"/> Where feasible, contours extend a minimum of 25 feet beyond property lines and extend sufficiently to depict existing conditions. |   |

### Temporary and Permanent BMPs

Include the following on site map (where applicable):

- |   |  |
|---|--|
| <input type="checkbox"/> Locations for temporary and permanent swales, interceptor trenches, or ditches.                                      | <input type="checkbox"/> Details for bypassing off-site runoff around disturbed areas.   |
| <input type="checkbox"/> Drainage pipes, ditches, or cut-off trenches associated with erosion and sediment control and stormwater management. | <input type="checkbox"/> Locations of temporary and permanent stormwater treatment and/or flow control best management practices (BMPs).   |
| <input type="checkbox"/> Temporary and permanent pipe inverts and minimum slopes and cover.   | <input type="checkbox"/> Details for all structural and nonstructural erosion and sediment control (ESC) BMPs (including, but not limited to, silt fences, construction entrances, sedimentation facilities, etc.) |
| <input type="checkbox"/> Grades, dimensions, and direction of flow in all ditches and swales, culverts, and pipes.                            | <input type="checkbox"/> Details for any construction-phase BMPs or techniques used for Low Impact Development (LID) BMP protection.   |
| <input type="checkbox"/> Locations and outlets of any dewatering systems.   |  |



# CITY OF MERCER ISLAND

## SECTION B: SMALL PROJECT CONSTRUCTION SWPPP NARRATIVE

### Element 1: Preserve Vegetation / Mark Clearing Limits

The goal of this element is to preserve native vegetation and to clearly show the limits of disturbance.

This element **does not** apply to my project because:

The site was cleared as part of clearing activity that is subject to an enforcement action and is re-vegetated. Restoration may be necessary to comply with Critical Area Regulations or NPDES requirements. Buffer Zones-BMP C102 may apply if Critical Areas exist on-site and buffer zones shall be protected.

Other Reason / Additional Comments:

If it **does** apply, describe the steps you will take and select the best management practices (BMPs) you will use:

The perimeter of the area to be cleared shall be marked prior to clearing operation with visible flagging, orange plastic barrier fencing and/or orange silt fencing as shown on the SWPPP site map. The total disturbed area shall be less than 7,000 square feet. Vehicles will only be allowed in the areas to be graded, so no compaction of the undeveloped areas will occur.

Additional Comments:

Check the BMPs you will use:

C101 Preserving Natural Vegetation

C102 Buffer Zones

C103 High Visibility Fence



# CITY OF MERCER ISLAND

## SECTION B: SMALL PROJECT CONSTRUCTION SWPPP NARRATIVE

### Element 2: Construction Access

The goal of this element is to provide a stabilized construction entrance/exit to prevent or reduce or sediment track out.

This element **does not** apply to my project because:

The driveway to the construction area already exists and will be used for construction access. All equipment and vehicles will be restricted to staying on that existing impervious surface.

Other Reason / Additional Comments:

If it **does** apply, describe the steps you will take and select the BMPs you will use:

A stabilized construction entrance will be installed prior to any vehicles entering the site, at the location shown on the SWPPP site map.

Additional Comments:

Check the BMPs you will use:

C105 Stabilized Construction Entrance / Exit

C106 Wheel Wash

C107 Construction Road / Parking Area Stabilization



# CITY OF MERCER ISLAND

## SECTION B: SMALL PROJECT CONSTRUCTION SWPPP NARRATIVE

### Element 3: Control Flow Rates

The goal of this element is to construct retention or detention facilities when necessary to protect properties and waterways downstream of development sites from erosion and turbid discharges.

This element **does not** apply to my project because:

Other Reason / Additional Comments:

If it **does** apply, describe the steps you will take and select the BMPs you will use:

Flow rates will be controlled by using SWPPP Element 4 sediment controls and BMP T5.13 Post-Construction Soil Quality and Depth if necessary.

Additional Comments:



# CITY OF MERCER ISLAND

## SECTION B: SMALL PROJECT CONSTRUCTION SWPPP NARRATIVE

### Element 4: Sediment Control

The goal of this element is to construct sediment control BMPs that minimize sediment discharges from the site.

This element **does not** apply to my project because:

The site has already been stabilized and re-vegetated.

Other Reason / Additional Comments:

If it **does** apply, describe the steps you will take and select the BMPs you will use:

Sediment control BMPs shall be placed at the locations shown on the SWPPP site map

Additional Comments:

Check the BMPs you will use:

C231 Brush Barrier

C233 Silt Fence

C235 Wattles

C232 Gravel Filter Berm

C234 Vegetated Strip



# CITY OF MERCER ISLAND

## SECTION B: SMALL PROJECT CONSTRUCTION SWPPP NARRATIVE

### Element 5: Stabilize Soils

The goal of this element is to stabilize exposed and unworked soils by implementing erosion control BMPs.

This element **does not** apply to my project because:

Other Reason / Additional Comments:

If it **does** apply, describe the steps you will take and select the BMPs you will use:

Exposed soils shall be worked during the week until they have been stabilized. Soil stockpiles will be located within the disturbed area shown on the SWPPP site map. Soil excavated for the foundation will be backfilled against the foundation and graded to drain away from the building. No soils shall remain exposed and unworked for more than 7 days from May 1 to September 30 or more than 2 days from October 1 to April 30. Once the disturbed landscape areas are graded, the grass areas will be amended using BMP T5.13 Post-Construction Soil Quality and Depth. All stockpiles will be covered with plastic or burlap if left unworked.

Additional Comments:

Check the BMPs you will use:

- C120 Temporary & Permanent Seeding
- C122 Nets & Blankets
- C124 Sodding
- C131 Gradient Terraces
- C235 Wattles
- C121 Mulching
- C123 Plastic Covering
- C125 Topsoil / Composting
- C140 Dust Control



# CITY OF MERCER ISLAND

## SECTION B: SMALL PROJECT CONSTRUCTION SWPPP NARRATIVE

### Element 6: Protect Slopes

The goal of this element is to design and construct cut-and-fill slopes in a manner to minimize erosion.

This element **does not** apply to my project because:

No cut slopes over 4 feet high or slopes steeper than 2 feet horizontal to 1 foot vertical, and no fill slopes over 4 feet high will exceed 3 feet horizontal to 1 foot vertical. Therefore, there is no requirement for additional engineered slope protection.

Other Reason / Additional Comments:

If it **does** apply, describe the steps you will take and select the BMPs you will use:

Additional Comments:

Check the BMPs you will use:

- |   |   |   |
|---|---|---|
| <input type="checkbox"/> C120 Temporary & Permanent Seeding | <input type="checkbox"/> C205 Subsurface Drains | <input type="checkbox"/> C207 Check Dams  |
| <input type="checkbox"/> C204 Pipe Slope Drains             | <input type="checkbox"/> C206 Level Spreader    | <input type="checkbox"/> C208 Triangular Silt Dike (Geotextile-Encased Check Dam) |



# CITY OF MERCER ISLAND

## SECTION B: SMALL PROJECT CONSTRUCTION SWPPP NARRATIVE

### Element 7: Protect Permanent Drain Inlets

The goal of this element is to protect storm drain inlets during construction to prevent stormwater runoff from entering the conveyance system without being filtered or treated.

*This element **does not** apply to my project because:*

- The site has open ditches in the right-of-way or private road right-of-way.
- There are no catch basins on or near the site.
- Other Reason / Additional Comments:

*If it **does** apply, describe the steps you will take and select the BMPs you will use:*

- Catch basins on the site or immediately off site in the right-of-way are shown on the SWPPP site map. Storm drain inlet protection shall be installed.

Additional Comments:

*Check the BMPs you will use:*

- C220 Storm Drain Inlet Protection



# CITY OF MERCER ISLAND

## SECTION B: SMALL PROJECT CONSTRUCTION SWPPP NARRATIVE

### Element 8: Stabilize Channels and Outlets

The goal of this element is to design, construct, and stabilize on-site conveyance channels to prevent erosion from entering existing stormwater outfalls and conveyance systems.

This element **does not** apply to my project because:

Construction will occur during the dry weather. No storm drainage channels or ditches shall be constructed either temporary or permanent. A small swale shall be graded to convey yard drainage around the structure using a shallow slope; it shall be seeded after grading and stabilized.

Other Reason / Additional Comments:

If it **does** apply, describe the steps you will take and select the BMPs you will use:

A wattle shall be placed at the end of the swale to prevent erosion at the outlet of the swale.

Additional Comments:

Check the BMPs you will use:

C202 Channel Lining     C207 Check Dams     C209 Outlet Protection     C235 Wattles



# CITY OF MERCER ISLAND

## SECTION B: SMALL PROJECT CONSTRUCTION SWPPP NARRATIVE

### Element 9: Control Pollutants

The goal of this element is to design, install, implement and maintain BMPs to minimize the discharge of pollutants from material storage areas, fuel handling, equipment cleaning, management of waste materials, etc.

This element **does not** apply to my project because:

Other Reason / Additional Comments:

If it **does** apply, describe the steps you will take and select the BMPs you will use:

Any and all pollutants, chemicals, liquid products and other materials that have the potential to pose a threat to human health or the environment will be covered, contained, and protected from vandalism. All such products shall be kept under cover in a secure location on-site. Concrete handling shall follow BMP C151.

Additional Comments:

Check the BMPs you will use:

C151 Concrete Handling

C152 Sawcutting and Surfacing Pollution Prevention

C153 Material Delivery, Storage, and Containment

C154 Concrete Washout Area



# CITY OF MERCER ISLAND

## SECTION B: SMALL PROJECT CONSTRUCTION SWPPP NARRATIVE

### Element 10: Control De-watering

The goal of this element is to handle turbid or contaminated dewatering water separately from stormwater.

This element **does not** apply to my project because:

No dewatering of the site is anticipated.

Other Reason / Additional Comments:

If it **does** apply, describe the steps you will take and select the BMPs you will use:

Additional Comments:

Check the BMPs you will use:

C203 Water Bars

C236 Vegetated Filtration

C206 Level Spreader



# CITY OF MERCER ISLAND

## SECTION B: SMALL PROJECT CONSTRUCTION SWPPP NARRATIVE

### Element 11: Maintain Best Management Practices

The goal of this element is to maintain and repair all temporary and permanent erosion and sediment control BMPs to assure continued performance.

*Describe the steps you will take:*

- Best Management Practices or BMPs shall be inspected and maintained during construction and removed within 30 days after the City Inspector or Engineer determines that the site is stabilized, provided that they may be removed when they are no longer needed.

### Element 12: Manage the Project

The goal of this element is to ensure that the construction SWPPP is properly coordinated and that all BMPs are deployed at the proper time to achieve full compliance with City regulations throughout the project.

If it **does** apply, describe the steps you will take and select the BMPs you will use:

The Construction SWPPP will be implemented at all times. The applicable erosion control BMPs will be implemented in the following sequence:

- 1. Mark clearing limits
- 2. Install stabilized construction entrance
- 3. Install protection for existing drainage systems and permanent drain inlets
- 4. Establish staging areas for storage and handling polluted material and BMPs
- 5. Install sediment control BMPs
- 6. Grade and install stabilization measures for disturbed areas
- 7. Maintain BMPs until site stabilization, at which time they may be removed

Additional Comments:



# CITY OF MERCER ISLAND

## SECTION B: SMALL PROJECT CONSTRUCTION SWPPP NARRATIVE

### Element 13: Protect Low Impact Development BMPs

The goal of this element is to protect on-site stormwater management BMPs (also known as “Low Impact Development BMPs”) from siltation and compaction during construction. On-site stormwater management BMPs used for runoff from roofs and other hard surfaces include: full dispersion, roof downspout full infiltration or dispersion systems, perforated stubout connections, rain gardens, bioretention systems, permeable pavement, sheetflow dispersion, and concentrated flow dispersion. Methods for protecting on-site stormwater management BMPs include sequencing the construction to install these BMPs at the latter part of the construction grading operations, excluding equipment from the BMPs and the associated areas, and using the erosion and sedimentation control BMPs listed below.

*Describe the construction sequencing you will use:*

Additional Comments:

*Select the BMPs you will use:*

- |   |   |   |
|---|---|---|
| <input type="checkbox"/> C102 Buffer Zone | <input type="checkbox"/> C103 High Visibility Fence | <input type="checkbox"/> C231 Brush Barrier |
| <input type="checkbox"/> C233 Silt Fence  | <input type="checkbox"/> C234 Vegetated Strip       |   |



# CITY OF MERCER ISLAND

## SECTION C: INFEASIBILITY CRITERIA

### Minimum Requirement #5 (On-Site Stormwater Management)

The following tables summarize infeasibility criteria that can be used to justify not using various on-site stormwater management best management practices (BMPs) for consideration for Minimum Requirement #5. This information is also included under the detailed descriptions of each BMP in the 2014 Stormwater Management Manual for Western Washington (Stormwater Manual), but is provided here in this worksheet for additional clarity and efficiency. Where any inconsistencies or lack of clarity exists, the requirements in the main text of the Stormwater Manual shall be applied. If a project is limited by one or more of the infeasibility criteria specified below, but an applicant is interested in implementing a specific BMP, a functionally equivalent design may be submitted to the City for review and approval. Evaluate the feasibility of the BMPs in priority order based on List #1 or #2 (Small Project Stormwater Requirements Tip Sheet and Stormwater Manual). Select the first BMP that is considered feasible for each surface type. Document the infeasibility (narrative description and rationale) for each BMP that was not selected. Only one infeasibility criterion needs to be selected for a BMP before evaluating the next BMP on the list. Attach additional pages for supporting information if necessary.

Note: If your project discharges directly to Lake Washington (flow control exempt) or a downstream analysis confirms that the downstream system is free of capacity constraints for a minimum of ¼ mile and a maximum of 1 mile, then you do not need to complete this worksheet, but should still refer to the infeasibility criteria when selecting BMPs.

Lawn and Landscaped Areas		
BMP and Applicable Lists	Infeasibility Criteria	Infeasibility Description and Rationale for Each BMP Not Selected
Post-construction Soil Quality and Depth List #1 and #2	<input type="checkbox"/> Siting and design criteria provided in BMP T5.13 ( <b>Stormwater Manual</b> Volume V, Section 5.3) cannot be achieved.  <input type="checkbox"/> Lawn and landscape area is on till slopes greater than 33 percent.	
Roofs		
BMP and Applicable Lists	Infeasibility Criteria	Infeasibility Description and Rationale for Each BMP Not Selected
Full Dispersion List #1 and #2	<input type="checkbox"/> Site setbacks and design criteria provided in BMP T5.30 ( <b>Stormwater Manual</b> Volume V, Section 5.3) cannot be achieved.  <input type="checkbox"/> A 65 to 10 ratio of forested or native vegetation area to impervious area cannot be achieved.  <input type="checkbox"/> A minimum forested or native vegetation flowpath length of 100 feet (25 feet for sheet flow from a non-native pervious surface) cannot be achieved.	
Downspout Full Infiltration List #1 and #2	<input type="checkbox"/> Evaluation of infiltration is not required per the Infiltration Infeasibility Map due to steep slopes, erosion hazards, or landslide hazards.  <input type="checkbox"/> Site setbacks and design criteria provided in BMP T5.10A ( <b>Stormwater Manual</b> Volume III, Section 3.1.1) cannot be achieved.  <input type="checkbox"/> The lot(s) or site does not have out-wash or loam soils.  <input type="checkbox"/> There is not at least 3 feet or more of permeable soil from the proposed final grade to the seasonal high groundwater table or other impermeable layer.  <input type="checkbox"/> There is not at least 1 foot or more of permeable soil from the proposed bottom of the infiltration system to the seasonal high groundwater table or other impermeable layer.	



# CITY OF MERCER ISLAND

## SECTION C: INFEASIBILITY CRITERIA

Roofs (cont.)		
BMP and Applicable Lists	Infeasibility Criteria	Infeasibility Description and Rationale for Each BMP Not Selected
<p>Bioretention or Rain Gardens</p> <p>List #1 (both) and List #2 (bioretention only)</p>	<p><i>Note: Criteria with setback distances are as measured from the bottom edge of the bioretention soil mix.</i></p> <p>Citation of any of the following infeasibility criteria must be based on an evaluation of site-specific conditions and a written recommendation from an appropriate licensed professional (e.g., engineer, geologist, hydrogeologist):</p> <ul style="list-style-type: none"> <li><input type="checkbox"/> Where professional geotechnical evaluation recommends infiltration not be used due to reasonable concerns about erosion, slope failure, or down-gradient flooding.</li> <li><input type="checkbox"/> Within an area whose ground water drains into an erosion hazard, or landslide hazard area.</li> <li><input type="checkbox"/> Where the only area available for siting would threaten the safety or reliability of pre-existing underground utilities, pre-existing underground storage tanks, pre-existing structures, or pre-existing road or parking lot surfaces.</li> <li><input type="checkbox"/> Where the only area available for siting does not allow for a safe overflow pathway to stormwater drainage system or private storm sewer system.</li> <li><input type="checkbox"/> Where there is a lack of usable space for bioretention areas at re-development sites, or where there is insufficient space within the existing public right-of-way on public road projects.</li> <li><input type="checkbox"/> Where infiltrating water would threaten existing below grade basements.</li> <li><input type="checkbox"/> Where infiltrating water would threaten shoreline structures such as bulkheads.</li> </ul> <p>The following criteria can be cited as reasons for infeasibility without further justification (though some require professional services to make the observation):</p> <ul style="list-style-type: none"> <li><input type="checkbox"/> Evaluation of infiltration is not required per the Infiltration Infeasibility Map due to steep slopes, erosion hazards, or landslide hazards</li> <li><input type="checkbox"/> Within setback provided for BMP T7.30 (<b>Stormwater Manual</b> Volume V, Section 7.4)</li> <li><input type="checkbox"/> Where they are not compatible with surrounding drainage system as determined by the city (e.g., project drains to an existing stormwater collection system whose elevation or location precludes connection to a properly functioning bioretention area).</li> </ul>	



# CITY OF MERCER ISLAND

## SECTION C: INFEASIBILITY CRITERIA

Roofs (cont.)		
BMP and Applicable Lists	Infeasibility Criteria	Infeasibility Description and Rationale for Each BMP Not Selected
Bioretention or Rain Gardens (cont.)	<p>The following criteria can be cited as reasons for infeasibility without further justification (though some require professional services to make the observation):</p> <ul style="list-style-type: none"> <li><input type="checkbox"/> Where land for bioretention is within an erosion hazard, or landslide hazard area (as defined by MICC 19.07.060).</li> <li><input type="checkbox"/> Where the site cannot be reasonably designed to locate bioretention areas on slopes less than 8 percent.</li> <li><input type="checkbox"/> Within 50 feet from the top of slopes that are greater than 20 percent and over 10 feet of vertical relief.</li> <li><input type="checkbox"/> For properties with known soil or groundwater contamination (typically federal Superfund sites or state cleanup sites under the Model Toxics Control Act [MTCA]):               <ul style="list-style-type: none"> <li>• Within 100 feet of an area known to have deep soil contamination.</li> <li>• Where groundwater modeling indicates infiltration will likely increase or change the direction of the migration of pollutants in the groundwater.</li> <li>• Wherever surface soils have been found to be contaminated unless those soils are removed within 10 horizontal feet from the infiltration area.</li> <li>• Any area where these facilities are prohibited by an approved cleanup plan under the state MTCA or Federal Superfund Law, or an environmental covenant under Chapter 64.70 RCW.</li> </ul> </li> <li><input type="checkbox"/> Within 100 feet of a closed or active landfill.</li> <li><input type="checkbox"/> Within 10 feet of an underground storage tank and connecting underground pipes when the capacity of the tank and pipe system is 1,100 gallons or less. As used in these criteria, an underground storage tank means any tank used to store petroleum products, chemicals, or liquid hazardous wastes of which 10 percent or more of the storage volume (including volume in the connecting piping system) is beneath the ground surface.</li> <li><input type="checkbox"/> Within 100 feet of an underground storage tank and connecting underground pipes when the capacity of the tank and pipe system is greater than 1,100 gallons.</li> </ul>	



# CITY OF MERCER ISLAND

## SECTION C: INFEASIBILITY CRITERIA

Roofs (cont.)		
BMP and Applicable Lists	Infeasibility Criteria	Infeasibility Description and Rationale for Each BMP Not Selected
Bioretention or Rain Gardens (cont.)	<p>The following criteria can be cited as reasons for infeasibility without further justification (though some require professional services to make the observation):</p> <ul style="list-style-type: none"> <li><input type="checkbox"/> Where field testing indicates potential bioretention/rain garden sites have a measured (a.k.a., initial) native soil saturated hydraulic conductivity less than 0.30 inches per hour. A small-scale or large-scale PIT in accordance with <b>Stormwater Manual</b> Volume III, Section 3.3.6 (or an alternative small scale test specified by the City) shall be used to demonstrate infeasibility of bioretention areas. If the measured native soil infiltration rate is less than 0.30 in/hour, bioretention/rain garden BMPs are not required to be evaluated as an option in List #1 or List #2. In these slow draining soils, a bioretention area with an underdrain may be used to treat pollution-generating surfaces to help meet Minimum Requirement #6, Runoff Treatment. If the underdrain is elevated within a base course of gravel, it will also provide some modest flow reduction benefit that will help achieve Minimum Requirement #7.</li> <li><input type="checkbox"/> Where the minimum vertical separation of 3 feet to the seasonal high groundwater elevation or other impermeable layer would not be achieved below bioretention that would serve a drainage area that exceeds the following thresholds (and cannot reasonably be broken down into amounts smaller than indicated):             <ul style="list-style-type: none"> <li>o 5,000 square feet of pollution-generating impervious surface (PGIS)</li> <li>o 10,000 square feet of impervious area</li> <li>o 0.75 acres of lawn and landscape.</li> </ul> </li> <li><input type="checkbox"/> Where the minimum vertical separation of 1 foot to the seasonal high groundwater or other impermeable layer would not be achieved below bioretention that would serve a drainage area less than the above thresholds.</li> <li><input type="checkbox"/> Within 100 feet of a drinking water well, or a spring used for drinking water supply.</li> <li><input type="checkbox"/> Within 10 feet of small on-site sewage disposal drainfield, including reserve areas, and grey water reuse systems. For setbacks from a "large on-site sewage disposal system," see Chapter 246-272B WAC.</li> </ul>	



# CITY OF MERCER ISLAND

## SECTION C: INFEASIBILITY CRITERIA

Roofs (cont.)		
BMP and Applicable Lists	Infeasibility Criteria	Infeasibility Description and Rationale for Each BMP Not Selected
<p>Downspout Dispersion Systems</p> <p>List #1 and #2</p>	<ul style="list-style-type: none"> <li><input type="checkbox"/> Site setbacks and design criteria provided in BMP T5.10B (<b>Stormwater Manual</b> Volume III, Section 3.1.2) cannot be achieved.</li> <li><input type="checkbox"/> For splash blocks, a vegetated flowpath at least 50 feet in length from the downspout to the downstream property line, structure, stream, wetland, slope over 15 percent, or other impervious surface is not feasible.</li> <li><input type="checkbox"/> For trenches, a vegetated flowpath of at least 25 feet in between the outlet of the trench and any property line, structure, stream, wetland, or impervious surface is not feasible. A vegetated flowpath of at least 50 feet between the outlet of the trench and any slope steeper than 15 percent is not feasible.</li> </ul>	
<p>Perforated Stub-Out Connections</p> <p>List #1 and #2</p>	<ul style="list-style-type: none"> <li><input type="checkbox"/> Evaluation of infiltration is not required per the Infiltration Infeasibility Map due to steep slopes, erosion hazards, or landslide hazards</li> <li><input type="checkbox"/> For sites with septic systems, the only location available for the perforated portion of the pipe is located up-gradient of the drainfield primary and reserve areas. This requirement can be waived if site topography will clearly prohibit flows from intersecting the drainfield or where site conditions (soil permeability, distance between systems, etc.) indicate that this is unnecessary.</li> <li><input type="checkbox"/> Site setbacks and design criteria provided in BMP T5.10C (<b>Stormwater Manual</b> Volume III, Section 3.1.3) cannot be achieved.</li> <li><input type="checkbox"/> There is not at least 1 foot of permeable soil from the proposed bottom (final grade) of the perforated stub-out connection trench to the highest estimated groundwater table or other impermeable layer.</li> <li><input type="checkbox"/> The only location available for the perforated stub-out connection is under impervious or heavily compacted soils.</li> </ul>	
<p>On-site Detention</p> <p>List #1 and #2</p>	<ul style="list-style-type: none"> <li><input type="checkbox"/> Project discharges directly to Lake Washington.</li> <li><input type="checkbox"/> Findings from a 1/4 mile downstream analysis confirm that the downstream system is free of capacity constraints.</li> <li><input type="checkbox"/> Site setbacks and design criteria provided in the <b>Stormwater Manual</b> (Volume III, Section 3.2.2) cannot be achieved.</li> </ul>	



# CITY OF MERCER ISLAND

## SECTION C: INFEASIBILITY CRITERIA

Other Hard Surfaces		
BMP and Applicable Lists	Infeasibility Criteria	Infeasibility Description and Rationale for Each BMP Not Selected
Full Dispersion List #1 and #2	<ul style="list-style-type: none"> <li><input type="checkbox"/> Site setbacks and design criteria provided in BMP T5.30 (<b>Stormwater Manual</b> Volume V, Section 5.3) cannot be achieved.</li> <li><input type="checkbox"/> A 65 to 10 ratio of forested or native vegetation area to impervious area cannot be achieved.</li> <li><input type="checkbox"/> A minimum forested or native vegetation flowpath length of 100 feet (25 feet for sheet flow from a non-native pervious surface) cannot be achieved.</li> </ul>	
Permeable Pavement List #1 and #2	<p>Citation of any of the following infeasibility criteria must be based on an evaluation of site-specific conditions and a written recommendation from an appropriate licensed professional (e.g., engineer, geologist, hydrogeologist):</p> <ul style="list-style-type: none"> <li><input type="checkbox"/> Where professional geotechnical evaluation recommends infiltration not be used due to reasonable concerns about erosion, slope failure, or downgradient flooding.</li> <li><input type="checkbox"/> Within an area whose ground water drains into an erosion hazard, or landslide hazard area.</li> <li><input type="checkbox"/> Where infiltrating and ponded water below the new permeable pavement area would compromise adjacent impervious pavements.</li> <li><input type="checkbox"/> Where infiltrating water below a new permeable pavement area would threaten existing below grade basements.</li> <li><input type="checkbox"/> Where infiltrating water would threaten shoreline structures such as bulkheads.</li> <li><input type="checkbox"/> Down slope of steep, erosion prone areas that are likely to deliver sediment.</li> <li><input type="checkbox"/> Where fill soils are used that can become unstable when saturated.</li> <li><input type="checkbox"/> Excessively steep slopes where water within the aggregate base layer or at the subgrade surface cannot be controlled by detention structures and may cause erosion and structural failure, or where surface runoff velocities may preclude adequate infiltration at the pavement surface.</li> <li><input type="checkbox"/> Where permeable pavements cannot provide sufficient strength to support heavy loads at industrial facilities such as ports.</li> <li><input type="checkbox"/> Where installation of permeable pavement would threaten the safety or reliability of pre-existing underground utilities, pre-existing underground storage tanks, or pre-existing road subgrades.</li> </ul>	



# CITY OF MERCER ISLAND

## SECTION C: INFEASIBILITY CRITERIA

Other Hard Surfaces (cont.)		
BMP and Applicable Lists	Infeasibility Criteria	Infeasibility Description and Rationale for Each BMP Not Selected
Permeable Pavement (cont.)	<p>The following criteria can be cited as reasons for infeasibility without further justification (though some require professional services to make the observation):</p> <ul style="list-style-type: none"> <li><input type="checkbox"/> Evaluation of infiltration is not required per the Infiltration Infeasibility Map due to steep slopes, erosion hazards, or landslide hazards</li> <li><input type="checkbox"/> Within an area designated as an erosion hazard, or landslide hazard.</li> <li><input type="checkbox"/> Within 50 feet from the top of slopes that are greater than 20 percent.</li> <li><input type="checkbox"/> For properties with known soil or groundwater contamination (typically federal Superfund sites or state cleanup sites under MTCA):               <ul style="list-style-type: none"> <li>• Within 100 feet of an area known to have deep soil contamination.</li> <li>• Where groundwater modeling indicates infiltration will likely increase or change the direction of the migration of pollutants in the groundwater.</li> <li>• Wherever surface soils have been found to be contaminated unless those soils are removed within 10 horizontal feet from the infiltration area.</li> <li>• Any area where these facilities are prohibited by an approved cleanup plan under the state MTCA or Federal Superfund Law, or an environmental covenant under Chapter 64.70 RCW.</li> </ul> </li> <li><input type="checkbox"/> Within 100 feet of a closed or active landfill.</li> <li><input type="checkbox"/> Within 100 feet of a drinking water well, or a spring used for drinking water supply, if the pavement is a pollution-generating surface.</li> <li><input type="checkbox"/> Within 10 feet of a small on-site sewage disposal drainfield, including reserve areas, and grey water reuse systems. For setbacks from a “large on-site sewage disposal system,” see Chapter 246-272B WAC.</li> <li><input type="checkbox"/> Within 10 feet of any underground storage tank and connecting underground pipes, regardless of tank size. As used in these criteria, an underground storage tank means any tank used to store petroleum products, chemicals, or liquid hazardous wastes of which 10 percent or more of the storage volume (including volume in the connecting piping system) is beneath the ground surface.</li> <li><input type="checkbox"/> At multi-level parking garages, and over culverts and bridges.</li> <li><input type="checkbox"/> Where the site design cannot avoid putting pavement in areas likely to have long-term excessive sediment deposition after construction (e.g., construction and landscaping material yards).</li> </ul>	



# CITY OF MERCER ISLAND

## SECTION C: INFEASIBILITY CRITERIA

Other Hard Surfaces (cont.)		
BMP and Applicable Lists	Infeasibility Criteria	Infeasibility Description and Rationale for Each BMP Not Selected
Permeable Pavement (cont.)	<p>The following criteria can be cited as reasons for infeasibility without further justification (though some require professional services to make the observation):</p> <ul style="list-style-type: none"> <li><input type="checkbox"/> Where the site cannot reasonably be designed to have:               <ul style="list-style-type: none"> <li>• Porous asphalt surface &lt; 5% slope</li> <li>• Pervious concrete surface &lt; 10% slope</li> <li>• Permeable interlocking concrete pavement surface &lt; 12% slope</li> <li>• Grid systems &lt; 6-12% slope (check with manufacturer and local supplier to confirm maximum slope)</li> </ul> </li>   <li><input type="checkbox"/> Where the subgrade soils below a pollution-generating permeable pavement (e.g., road or parking lot) do not meet the soil suitability criteria for providing treatment. See soil suitability criteria for treatment in the <b>Stormwater Manual</b> Volume III, Section 3.3.7. Note: In these instances, the city may approve installation of a 6 inch sand filter layer meeting city specifications for treatment as a condition of construction.</li>   <li><input type="checkbox"/> Where underlying soils are unsuitable for supporting traffic loads when saturated. Soils meeting a California Bearing Ratio of 5 percent are considered suitable for residential access roads.</li>   <li><input type="checkbox"/> Where replacing existing impervious surfaces unless the existing surface is a non-pollution generating surface over an outwash soil with a saturated hydraulic conductivity of 4 inches per hour or greater.</li>   <li><input type="checkbox"/> Where appropriate field testing indicates soils have a measured (a.k.a., initial) subgrade soil saturated hydraulic conductivity less than 0.3 inches per hour. Only small-scale PIT or large-scale PIT methods in accordance with <b>Stormwater Manual</b> Volume III, Section 3.3.6 (or an alternative small scale test specified by the City) shall be used to evaluate infeasibility of permeable pavement areas. (Note: In these instances, unless other infeasibility restrictions apply, roads and parking lots may be built with an underdrain, preferably elevated within the base course, if flow control benefits are desired.)</li>   <li><input type="checkbox"/> Roads that receive more than very low traffic volumes, and areas having more than very low truck traffic. Roads with a projected average daily traffic volume of 400 vehicles or less are very low volume roads (AASHTO 2001) (U.S. Department of Transportation, 2013). Areas with very low truck traffic volumes are roads and other areas not subject to through truck traffic but may receive up to weekly use by utility trucks (e.g., garbage, recycling), daily school bus use, and multiple daily use by pick-up trucks, mail/parcel delivery trucks, and maintenance vehicles. (Note: This infeasibility criterion does not extend to sidewalks and other non-traffic bearing surfaces associated with the collector or arterial).</li> </ul>	



# CITY OF MERCER ISLAND

## SECTION C: INFEASIBILITY CRITERIA

Other Hard Surfaces (cont.)		
BMP and Applicable Lists	Infeasibility Criteria	Infeasibility Description and Rationale for Each BMP Not Selected
Permeable Pavement (cont.)	<p>The following criteria can be cited as reasons for infeasibility without further justification (though some require professional services to make the observation):</p> <ul style="list-style-type: none"> <li><input type="checkbox"/> At sites defined as “high-use sites” (refer to the Glossary in the <b>Stormwater Manual</b> Volume I).</li> <li><input type="checkbox"/> In areas with “industrial activity” as identified in 40 CFR 122.26(b)(14).</li> <li><input type="checkbox"/> Where the risk of concentrated pollutant spills is more likely such as gas stations, truck stops, and industrial chemical storage sites.</li> <li><input type="checkbox"/> Where routine, heavy applications of sand occur in frequent snow zones to maintain traction during weeks of snow and ice accumulation.</li> <li><input type="checkbox"/> Where the seasonal high groundwater or an underlying impermeable/low permeable layer would create saturated conditions within 1 foot of the bottom of the lowest gravel base course.</li> </ul>	
Bioretention or Rain Gardens  List #1 (both) and List #2 (bioretention only)	<p><i>Note: Criteria with setback distances are as measured from the bottom edge of the bioretention soil mix.</i></p> <p>Citation of any of the following infeasibility criteria must be based on an evaluation of site-specific conditions and a written recommendation from an appropriate licensed professional (e.g., engineer, geologist, hydrogeologist):</p> <ul style="list-style-type: none"> <li><input type="checkbox"/> Where professional geotechnical evaluation recommends infiltration not be used due to reasonable concerns about erosion, slope failure, or down-gradient flooding.</li> <li><input type="checkbox"/> Within an area whose ground water drains into an erosion hazard, or landslide hazard area.</li> <li><input type="checkbox"/> Where the only area available for siting would threaten the safety or reliability of pre-existing underground utilities, pre-existing underground storage tanks, pre-existing structures, or pre-existing road or parking lot surfaces.</li> <li><input type="checkbox"/> Where the only area available for siting does not allow for a safe overflow pathway to stormwater drainage system or private storm sewer system.</li> <li><input type="checkbox"/> Where there is a lack of usable space for bioretention areas at re-development sites, or where there is insufficient space within the existing public right-of-way on public road projects.</li> <li><input type="checkbox"/> Where infiltrating water would threaten existing below grade basements.</li> <li><input type="checkbox"/> Where infiltrating water would threaten shoreline structures such as bulkheads.</li> </ul>	



# CITY OF MERCER ISLAND

## SECTION C: INFEASIBILITY CRITERIA

Other Hard Surfaces (cont.)		
BMP and Applicable Lists	Infeasibility Criteria	Infeasibility Description and Rationale for Each BMP Not Selected
Bioretention or Rain Gardens (cont.)	<p>The following criteria can be cited as reasons for infeasibility without further justification (though some require professional services to make the observation):</p> <ul style="list-style-type: none"> <li><input type="checkbox"/> Where evaluation of infiltration is not required per the Infiltration Infeasibility Map due to steep slopes, erosion hazards, or landslide hazards.</li> <li><input type="checkbox"/> Within setback provided for BMP T7.30 (<b>Stormwater Manual</b> Volume V, Section 7.4)</li> <li><input type="checkbox"/> Where they are not compatible with surrounding drainage system as determined by the city (e.g., project drains to an existing stormwater collection system whose elevation or location precludes connection to a properly functioning bioretention area).</li> <li><input type="checkbox"/> Where land for bioretention is within an erosion hazard, or landslide hazard area (as defined by MICC 19.07.060).</li> <li><input type="checkbox"/> Where the site cannot be reasonably designed to locate bioretention areas on slopes less than 8 percent.</li> <li><input type="checkbox"/> Within 50 feet from the top of slopes that are greater than 20 percent and over 10 feet of vertical relief.</li> <li><input type="checkbox"/> For properties with known soil or groundwater contamination (typically federal Superfund sites or state cleanup sites under the Model Toxics Control Act [MTCA]):               <ul style="list-style-type: none"> <li>• Within 100 feet of an area known to have deep soil contamination.</li> <li>• Where groundwater modeling indicates infiltration will likely increase or change the direction of the migration of pollutants in the groundwater.</li> <li>• Wherever surface soils have been found to be contaminated unless those soils are removed within 10 horizontal feet from the infiltration area.</li> <li>• Any area where these facilities are prohibited by an approved cleanup plan under the state MTCA or Federal Superfund Law, or an environmental covenant under Chapter 64.70 RCW.</li> </ul> </li> <li><input type="checkbox"/> Within 100 feet of a closed or active landfill.</li> <li><input type="checkbox"/> Within 10 feet of an underground storage tank and connecting underground pipes when the capacity of the tank and pipe system is 1,100 gallons or less. As used in these criteria, an underground storage tank means any tank used to store petroleum products, chemicals, or liquid hazardous wastes of which 10 percent or more of the storage volume (including volume in the connecting piping system) is beneath the ground surface.</li> </ul>	



# CITY OF MERCER ISLAND

## SECTION C: INFEASIBILITY CRITERIA

Other Hard Surfaces (cont.)		
BMP and Applicable Lists	Infeasibility Criteria	Infeasibility Description and Rationale for Each BMP Not Selected
Bioretention or Rain Gardens (cont.)	<p>The following criteria can be cited as reasons for infeasibility without further justification (though some require professional services to make the observation):</p> <ul style="list-style-type: none"> <li><input type="checkbox"/> Within 100 feet of an underground storage tank and connecting underground pipes when the capacity of the tank and pipe system is greater than 1,100 gallons.</li> <li><input type="checkbox"/> Where field testing indicates potential bioretention/rain garden sites have a measured (a.k.a., initial) native soil saturated hydraulic conductivity less than 0.30 inches per hour. A small-scale or large-scale PIT in accordance with <b>Stormwater Manual</b> Volume III, Section 3.3.6 (or an alternative small scale test specified by the City) shall be used to demonstrate infeasibility of bioretention areas. If the measured native soil infiltration rate is less than 0.30 in/hour, bioretention/rain garden BMPs are not required to be evaluated as an option in List #1 or List #2. In these slow draining soils, a bioretention area with an underdrain may be used to treat pollution-generating surfaces to help meet Minimum Requirement #6, Runoff Treatment. If the underdrain is elevated within a base course of gravel, it will also provide some modest flow reduction benefit that will help achieve Minimum Requirement #7.</li> <li><input type="checkbox"/> Where the minimum vertical separation of 3 feet to the seasonal high groundwater elevation or other impermeable layer would not be achieved below bioretention that would serve a drainage area that exceeds the following thresholds (and cannot reasonably be broken down into amounts smaller than indicated):             <ul style="list-style-type: none"> <li>o 5,000 square feet of pollution-generating impervious surface (PGIS)</li> <li>o 10,000 square feet of impervious area</li> <li>o 0.75 acres of lawn and landscape.</li> </ul> </li> <li><input type="checkbox"/> Where the minimum vertical separation of 1 foot to the seasonal high groundwater or other impermeable layer would not be achieved below bioretention that would serve a drainage area less than the above thresholds</li> <li><input type="checkbox"/> Within 100 feet of a drinking water well, or a spring used for drinking water supply.</li> <li><input type="checkbox"/> Within 10 feet of small on-site sewage disposal drainfield, including reserve areas, and grey water reuse systems. For setbacks from a "large on-site sewage disposal system," see Chapter 246-272B WAC.</li> </ul>	



# CITY OF MERCER ISLAND

## SECTION C: INFEASIBILITY CRITERIA

Other Hard Surfaces (cont.)		
BMP and Applicable Lists	Infeasibility Criteria	Infeasibility Description and Rationale for Each BMP Not Selected
Sheet Flow Dispersion List #1 and #2	<ul style="list-style-type: none"> <li><input type="checkbox"/> Site setbacks and design criteria provided in BMP T5.12 (<b>Stormwater Manual</b> Volume V, Section 5.3) cannot be achieved.</li> <li><input type="checkbox"/> Positive drainage for sheet flow runoff cannot be achieved.</li> <li><input type="checkbox"/> Area to be dispersed (e.g., driveway, patio) cannot be graded to have less than a 15 percent slope.</li> <li><input type="checkbox"/> For flat to moderately sloped areas, at least a 10 foot-wide vegetation buffer for dispersion of the adjacent 20 feet of contributing surface cannot be achieved. For variably sloped areas, at least a 25 foot vegetated flowpath between berms cannot be achieved.</li> </ul>	
Concentrated Flow Dispersion List #1 and #2	<ul style="list-style-type: none"> <li><input type="checkbox"/> Site setbacks and design criteria provided in BMP T5.11 (<b>Stormwater Manual</b> Volume V, Section 5.3) cannot be achieved.</li> <li><input type="checkbox"/> A minimum 3 foot length of rock pad and 50 foot flowpath OR a dispersion trench and 25 foot flowpath for every 700 square feet of drainage area followed with applicable setbacks cannot be achieved.</li> <li><input type="checkbox"/> More than 700 square feet drainage area drains to any dispersion device.</li> </ul>	
On-site Detention List #1 and #2	<ul style="list-style-type: none"> <li><input type="checkbox"/> Project discharges directly to Lake Washington.</li> <li><input type="checkbox"/> Findings from a 1/4 mile downstream analysis confirm that the downstream system is free of capacity constraints.</li> <li><input type="checkbox"/> Site setbacks and design criteria provided in the <b>Stormwater Manual</b> (Volume III, Section 3.2.2) cannot be achieved.</li> </ul>	



# CITY OF MERCER ISLAND

## SECTION D: POST-CONSTRUCTION SOIL MANAGEMENT

### Attachments Required *(Check off required items that are attached)*

- Site Plan showing, to scale:
  - Areas of undisturbed native vegetation (no amendment required)
  - New planting beds (amendment required)
  - New turf areas (amendment required)
  - Type of soil improvement proposed for each area

Soil test results (required if proposing custom amendment rates)

Product test results for proposed amendments

### Total Amendment / Topsoil / Mulch for All Areas

Calculate the quantities needed for the entire site based on all of the areas identified on the Site Plan and the calculations on the following page(s):

Product	Total Quantity (CY)	Test Results
Product #1: _____	_____ CY	_____ % organic matter _____ C:N ratio "Stable"? yes <input type="checkbox"/> no <input type="checkbox"/>
Product #2: _____	_____ CY	_____ % organic matter _____ C:N ratio "Stable"? yes <input type="checkbox"/> no <input type="checkbox"/>
Product #3: _____	_____ CY	_____ % organic matter _____ C:N ratio "Stable"? yes <input type="checkbox"/> no <input type="checkbox"/>

CY = cubic yards, C:N = Carbon:Nitrogen



# CITY OF MERCER ISLAND

## SECTION D: POST-CONSTRUCTION SOIL MANAGEMENT

### Amendment / Topsoil / Mulch by Area

For each identified area on your Site Plan, provide the following information: (Use additional sheets if necessary)

Area # \_\_\_\_\_ (should match identified Area # on Site Plan)

Planting type:  Turf  Undisturbed native vegetation  
 Planting Beds  Other: \_\_\_\_\_

### Pre-Approved Amendment Method

<input type="checkbox"/>	Amend with compost Turf: _____ SF x 5.4 CY ÷ 1,000 SF = _____ CY Planting beds: _____ SF x 9.3 CY ÷ 1,000 SF = _____ CY Total Quantity = _____ CY Scarification depth: 8 inches	Product: _____
<input type="checkbox"/>	Stockpile and amend Turf: _____ SF x 5.4 CY ÷ 1,000 SF = _____ CY Planting beds: _____ SF x 9.3 CY ÷ 1,000 SF = _____ CY Total Quantity = _____ CY Scarification depth: 8 inches	Product: _____
<input type="checkbox"/>	Topsoil import Turf: _____ SF x 18.6 CY ÷ 1,000 SF = _____ CY Planting beds: _____ SF x 18.6 CY ÷ 1,000 SF = _____ CY Total Quantity = _____ CY Scarification depth: 6 inches	Product: _____

### Custom Amendment

<input type="checkbox"/>	Amend with compost Attach information on bulk density, percent organic matter, moisture content, C:N ratio, and heavy metals analysis to support custom amendment rate and scarification depth. Total Quantity = _____ CY Scarification depth: _____ inches	Product: _____
<input type="checkbox"/>	Stockpile and amend Attach information on bulk density, percent organic matter, moisture content, C:N ratio, and heavy metals analysis to support custom amendment rate and scarification depth. Total Quantity = _____ CY Scarification depth: _____ inches	Product: _____

### Mulch

<input type="checkbox"/>	Amend with compost Planting beds: _____ SF x 12.4 CY ÷ 1,000 SF = _____ CY Total Quantity = _____ CY	Product: _____
<input type="checkbox"/>	Stockpile and amend Planting beds: _____ SF x 12.4 CY ÷ 1,000 SF = _____ CY Total Quantity = _____ CY	Product: _____
<input type="checkbox"/>	Topsoil import Planting beds: _____ SF x 12.4 CY ÷ 1,000 SF = _____ CY Total Quantity = _____ CY	Product: _____

CY = cubic yards, C:N = Carbon:Nitrogen



# CITY OF MERCER ISLAND

## SECTION E: SIGNATURE PAGE

### Project Engineer's Certification for Section B

For Stormwater Site Plans with engineered elements, the Construction SWPPP is stamped by a professional engineer licensed in the State of Washington in civil engineering.

If required, attach a page with the project engineer's seal with the following statement:

*"I hereby state that this Construction Stormwater Pollution Prevention Plan for \_\_\_\_\_  
(name of project)  
has been prepared by me or under my supervision and meets the standard of care and expertise which is usual and customary in this community for professional engineers. I understand that the City of Mercer Island does not and will not assume liability for the sufficiency, suitability, or performance of Construction SWPPP BMPs prepared by me."*

### Applicant Signature for Full Stormwater Package (Sections A through D)

I have read and completed the Stormwater Submittal Package and know the information provided to be true and correct.

Print Applicant Name: \_\_\_\_\_

Applicant Signature: Andrew C.P. Date \_\_\_\_\_

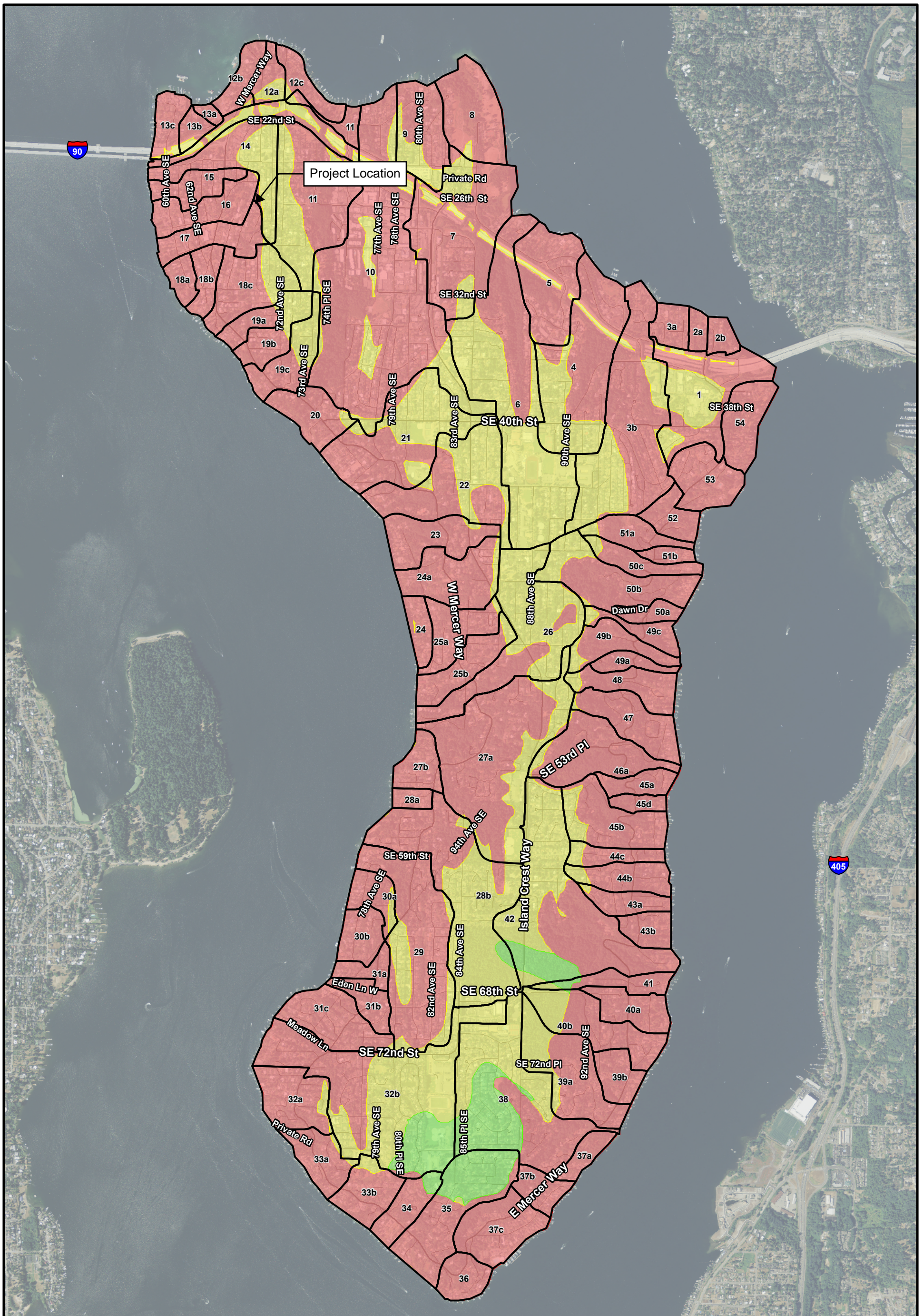

**Legend**

- Infiltrating LID facilities may be feasible, and soil has high infiltration potential
- Infiltrating LID facilities may be feasible, and soil has moderate infiltration potential
- Infiltrating LID facilities are not permitted
- Storm drainage basin

**Figure 3. Low impact development infiltration feasibility on Mercer Island.**

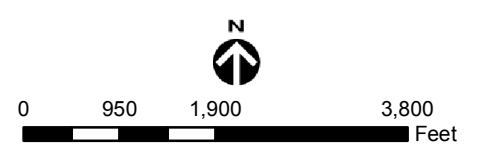

Aerial photography: USDA (2009)  
 K:\Projects\10-04816-000\Project\lid\_feasibility-report-11x17.mxd

\* Map is intended to be used for planning purposes only. Site-specific analysis is required prior to design and construction of LID facilities.

2707 Mercer SFR - Downstream Map

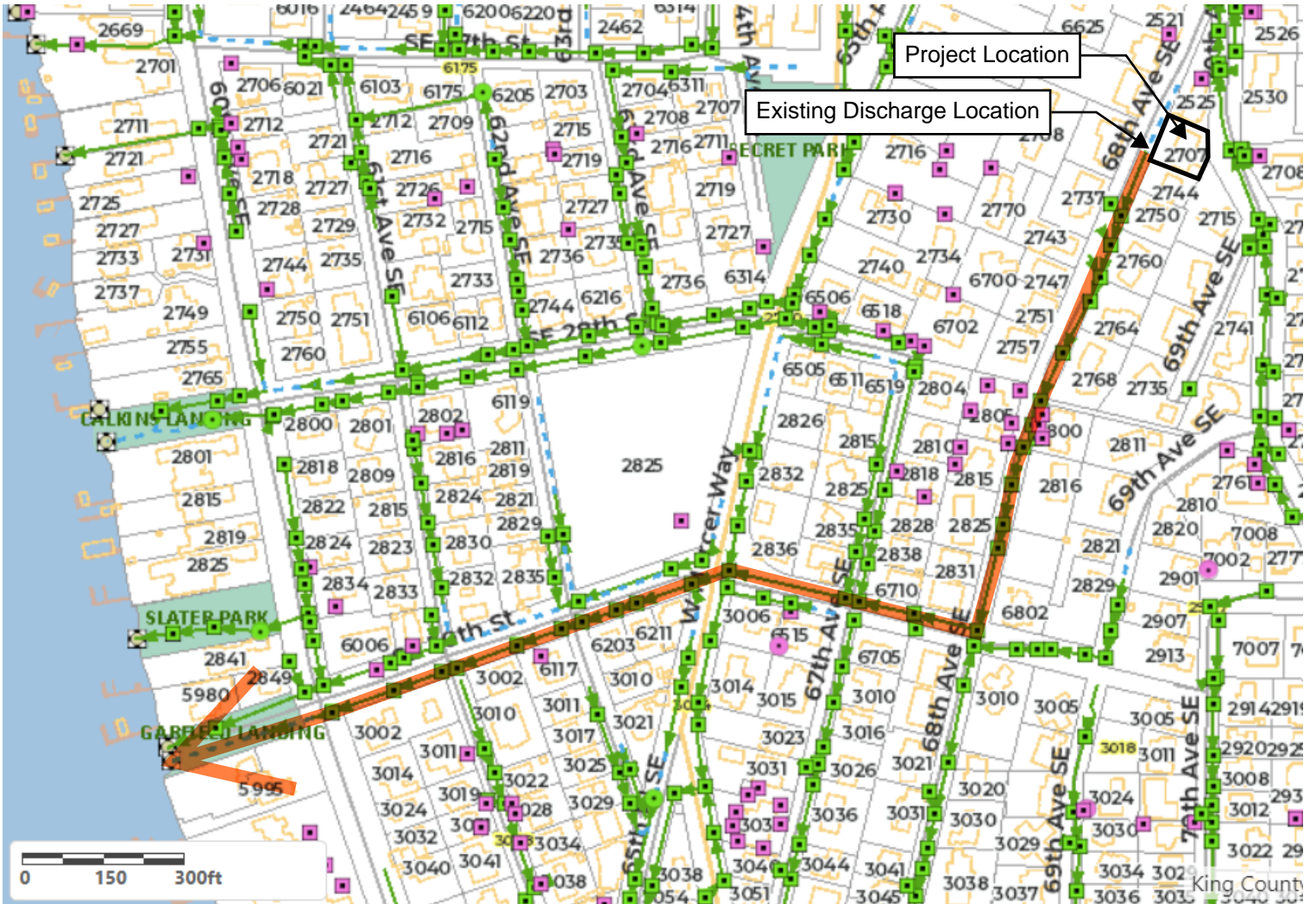

**WWHM2012**  
**PROJECT REPORT**

## General Model Information

WWHM2012 Project Name: default[10]

Site Name: 2707 Mercer SFR

Site Address:

City:

Report Date: 10/31/2025

Gage: Seatac

Data Start: 1948/10/01

Data End: 2009/09/30

Timestep: 15 Minute

Precip Scale: 1.000

Version Date: 2025/05/13

Version: 4.3.2

## POC Thresholds

---

Low Flow Threshold for POC1: 50 Percent of the 2 Year

High Flow Threshold for POC1: 50 Year

---

*Landuse Basin Data*  
*Predeveloped Land Use*

**Basin 1**

Bypass:	No
GroundWater:	No
Pervious Land Use	acre
Pervious Total	0
Impervious Land Use	acre
ROADS FLAT	0.058
Impervious Total	0.058
Basin Total	0.058

Element Flow Componants:  
Surface Interflow Groundwater  
Componant Flows To:  
POC 1 POC 1

*Mitigated Land Use*

**Basin 1**

Bypass:	No
GroundWater:	No
Pervious Land Use	acre
Pervious Total	0
Impervious Land Use	acre
ROADS FLAT	0.058
Impervious Total	0.058
Basin Total	0.058

Element Flow Components:  
Surface Interflow Groundwater  
Component Flows To:  
POC 1 POC 1

*Routing Elements*  
*Predeveloped Routing*

*Mitigated Routing*

# Analysis Results

## POC 1

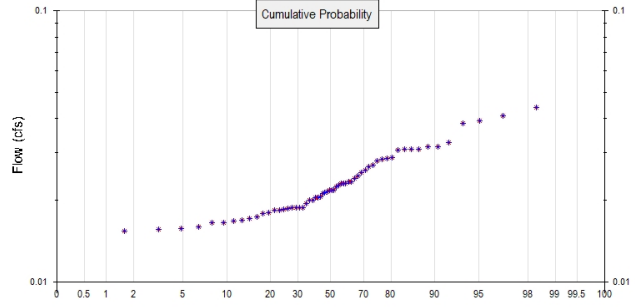
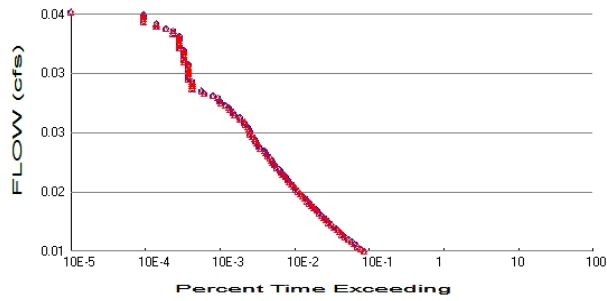

+ Predeveloped    x Mitigated

### Predeveloped Landuse Totals for POC #1

Total Pervious Area: 0  
 Total Impervious Area: 0.058

### Mitigated Landuse Totals for POC #1

Total Pervious Area: 0  
 Total Impervious Area: 0.058

Flow Frequency Method: Log Pearson Type III 17B

### Flow Frequency Return Periods for Predeveloped. POC #1

Return Period	Flow(cfs)
2 year	0.022113
5 year	0.027932
10 year	0.031885
25 year	0.037013
50 year	0.040938
100 year	0.044958

### Flow Frequency Return Periods for Mitigated. POC #1

Return Period	Flow(cfs)
2 year	0.022113
5 year	0.027932
10 year	0.031885
25 year	0.037013
50 year	0.040938
100 year	0.044958

## Annual Peaks

### Annual Peaks for Predeveloped and Mitigated. POC #1

Year	Predeveloped	Mitigated
1949	0.029	0.029
1950	0.031	0.031
1951	0.018	0.018
1952	0.016	0.016
1953	0.017	0.017
1954	0.018	0.018
1955	0.020	0.020
1956	0.020	0.020
1957	0.023	0.023
1958	0.018	0.018

1959	0.019	0.019
1960	0.018	0.018
1961	0.019	0.019
1962	0.017	0.017
1963	0.019	0.019
1964	0.018	0.018
1965	0.023	0.023
1966	0.016	0.016
1967	0.027	0.027
1968	0.031	0.031
1969	0.021	0.021
1970	0.021	0.021
1971	0.025	0.025
1972	0.025	0.025
1973	0.015	0.015
1974	0.022	0.022
1975	0.026	0.026
1976	0.017	0.017
1977	0.019	0.019
1978	0.023	0.023
1979	0.031	0.031
1980	0.028	0.028
1981	0.023	0.023
1982	0.033	0.033
1983	0.027	0.027
1984	0.017	0.017
1985	0.023	0.023
1986	0.020	0.020
1987	0.031	0.031
1988	0.019	0.019
1989	0.023	0.023
1990	0.039	0.039
1991	0.031	0.031
1992	0.017	0.017
1993	0.014	0.014
1994	0.016	0.016
1995	0.020	0.020
1996	0.022	0.022
1997	0.021	0.021
1998	0.021	0.021
1999	0.044	0.044
2000	0.022	0.022
2001	0.024	0.024
2002	0.028	0.028
2003	0.022	0.022
2004	0.041	0.041
2005	0.019	0.019
2006	0.017	0.017
2007	0.038	0.038
2008	0.031	0.031
2009	0.029	0.029

### Ranked Annual Peaks

Ranked Annual Peaks for Predeveloped and Mitigated. POC #1

Rank	Predeveloped	Mitigated
1	0.0439	0.0439
2	0.0411	0.0411
3	0.0394	0.0394

4	0.0384	0.0384
5	0.0326	0.0326
6	0.0315	0.0315
7	0.0315	0.0315
8	0.0309	0.0309
9	0.0309	0.0309
10	0.0308	0.0308
11	0.0307	0.0307
12	0.0286	0.0286
13	0.0286	0.0286
14	0.0282	0.0282
15	0.0280	0.0280
16	0.0270	0.0270
17	0.0265	0.0265
18	0.0258	0.0258
19	0.0254	0.0254
20	0.0246	0.0246
21	0.0240	0.0240
22	0.0234	0.0234
23	0.0234	0.0234
24	0.0231	0.0231
25	0.0231	0.0231
26	0.0230	0.0230
27	0.0228	0.0228
28	0.0224	0.0224
29	0.0219	0.0219
30	0.0218	0.0218
31	0.0218	0.0218
32	0.0215	0.0215
33	0.0214	0.0214
34	0.0212	0.0212
35	0.0206	0.0206
36	0.0205	0.0205
37	0.0204	0.0204
38	0.0201	0.0201
39	0.0200	0.0200
40	0.0194	0.0194
41	0.0188	0.0188
42	0.0188	0.0188
43	0.0188	0.0188
44	0.0187	0.0187
45	0.0187	0.0187
46	0.0185	0.0185
47	0.0184	0.0184
48	0.0184	0.0184
49	0.0180	0.0180
50	0.0179	0.0179
51	0.0174	0.0174
52	0.0172	0.0172
53	0.0169	0.0169
54	0.0167	0.0167
55	0.0166	0.0166
56	0.0166	0.0166
57	0.0159	0.0159
58	0.0157	0.0157
59	0.0156	0.0156
60	0.0154	0.0154
61	0.0143	0.0143



## Duration Flows

The Facility PASSED

Flow(cfs)	Predev	Mit	Percentage	Pass/Fail
0.0111	1806	1806	100	Pass
0.0114	1639	1639	100	Pass
0.0117	1472	1472	100	Pass
0.0120	1343	1343	100	Pass
0.0123	1228	1228	100	Pass
0.0126	1104	1104	100	Pass
0.0129	1005	1005	100	Pass
0.0132	922	922	100	Pass
0.0135	853	853	100	Pass
0.0138	791	791	100	Pass
0.0141	726	726	100	Pass
0.0144	666	666	100	Pass
0.0147	611	611	100	Pass
0.0150	571	571	100	Pass
0.0153	532	532	100	Pass
0.0156	488	488	100	Pass
0.0159	451	451	100	Pass
0.0162	420	420	100	Pass
0.0165	389	389	100	Pass
0.0168	364	364	100	Pass
0.0171	339	339	100	Pass
0.0174	316	316	100	Pass
0.0177	296	296	100	Pass
0.0180	272	272	100	Pass
0.0183	256	256	100	Pass
0.0186	238	238	100	Pass
0.0189	221	221	100	Pass
0.0192	207	207	100	Pass
0.0195	196	196	100	Pass
0.0198	181	181	100	Pass
0.0201	171	171	100	Pass
0.0204	161	161	100	Pass
0.0207	148	148	100	Pass
0.0210	139	139	100	Pass
0.0213	135	135	100	Pass
0.0216	122	122	100	Pass
0.0219	113	113	100	Pass
0.0222	108	108	100	Pass
0.0225	105	105	100	Pass
0.0228	100	100	100	Pass
0.0231	92	92	100	Pass
0.0234	87	87	100	Pass
0.0237	84	84	100	Pass
0.0240	73	73	100	Pass
0.0243	71	71	100	Pass
0.0246	66	66	100	Pass
0.0249	63	63	100	Pass
0.0252	62	62	100	Pass
0.0255	58	58	100	Pass
0.0258	54	54	100	Pass
0.0261	54	54	100	Pass
0.0265	52	52	100	Pass
0.0268	50	50	100	Pass

0.0271	46	46	100	Pass
0.0274	45	45	100	Pass
0.0277	40	40	100	Pass
0.0280	39	39	100	Pass
0.0283	33	33	100	Pass
0.0286	32	32	100	Pass
0.0289	29	29	100	Pass
0.0292	28	28	100	Pass
0.0295	25	25	100	Pass
0.0298	22	22	100	Pass
0.0301	21	21	100	Pass
0.0304	20	20	100	Pass
0.0307	17	17	100	Pass
0.0310	13	13	100	Pass
0.0313	12	12	100	Pass
0.0316	9	9	100	Pass
0.0319	9	9	100	Pass
0.0322	9	9	100	Pass
0.0325	9	9	100	Pass
0.0328	8	8	100	Pass
0.0331	8	8	100	Pass
0.0334	8	8	100	Pass
0.0337	8	8	100	Pass
0.0340	8	8	100	Pass
0.0343	8	8	100	Pass
0.0346	8	8	100	Pass
0.0349	7	7	100	Pass
0.0352	7	7	100	Pass
0.0355	7	7	100	Pass
0.0358	7	7	100	Pass
0.0361	7	7	100	Pass
0.0364	7	7	100	Pass
0.0367	6	6	100	Pass
0.0370	6	6	100	Pass
0.0373	6	6	100	Pass
0.0376	6	6	100	Pass
0.0379	6	6	100	Pass
0.0382	6	6	100	Pass
0.0385	5	5	100	Pass
0.0388	5	5	100	Pass
0.0391	4	4	100	Pass
0.0394	3	3	100	Pass
0.0397	3	3	100	Pass
0.0400	2	2	100	Pass
0.0403	2	2	100	Pass
0.0406	2	2	100	Pass
0.0409	2	2	100	Pass

## Water Quality

Water Quality BMP Flow and Volume for POC #1

On-line facility volume: 0 acre-feet

On-line facility target flow: 0 cfs.

Adjusted for 15 min: 0 cfs.

Off-line facility target flow: 0 cfs.

Adjusted for 15 min: 0 cfs.

## *Model Default Modifications*

Total of 0 changes have been made.

### *PERLND Changes*

No PERLND changes have been made.

### *IMPLND Changes*

No IMPLND changes have been made.

# Appendix

## Predeveloped Schematic



Mitigated Schematic

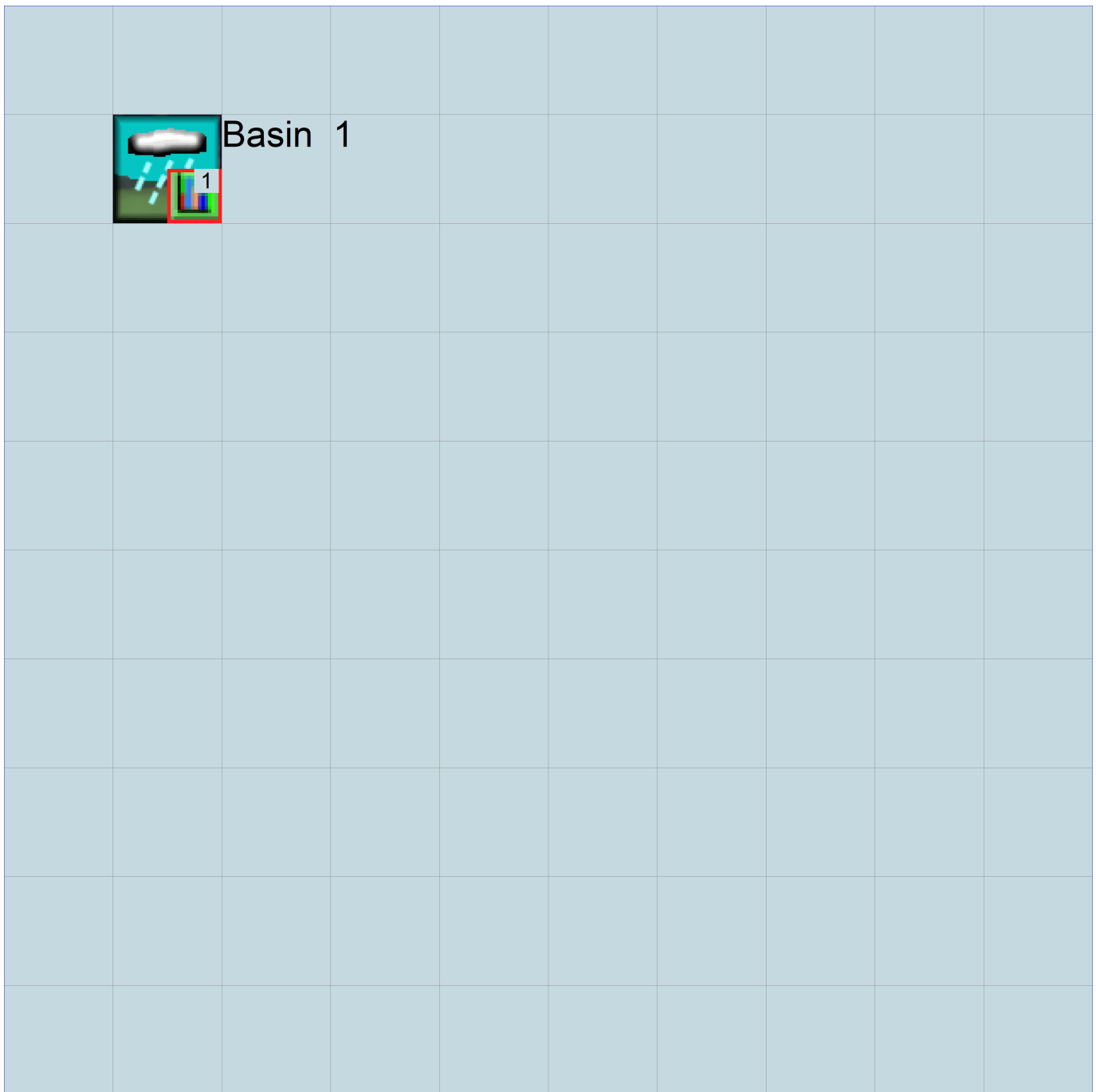

## Predeveloped UCI File

RUN

GLOBAL

```

WVHM4 model simulation
START      1948 10 01      END      2009 09 30
RUN INTERP OUTPUT LEVEL    3      0
RESUME     0 RUN          1              UNIT SYSTEM    1
END GLOBAL

```

FILES

```

<File>  <Un#>  <-----File Name----->***
<-ID->                                     ***
WDM      26     default[10].wdm
MESSU    25     Predefault[10].MES
          27     Predefault[10].L61
          28     Predefault[10].L62
          30     POCdefault[10]1.dat
END FILES

```

OPN SEQUENCE

```

INGRP              INDELT 00:15
  IMPLND           1
  COPY             501
  DISPLY           1
END INGRP
END OPN SEQUENCE

```

DISPLY

```

DISPLY-INF01
# - #<-----Title----->***TRAN PIVL DIG1 FIL1  PYR DIG2 FIL2 YRND
1   Basin 1              MAX                1   2   30   9
END DISPLY-INF01
END DISPLY

```

COPY

```

TIMESERIES
# - #  NPT  NMN  ***
1   1   1   1
501 1   1   1
END TIMESERIES
END COPY

```

GENER

```

OPCODE
#   # OPCD ***
END OPCODE
PARM
#   #           K ***
END PARM
END GENER

```

PERLND

```

GEN-INFO
<PLS ><-----Name----->NBLKS  Unit-systems  Printer ***
# - #                               User t-series Engl Metr ***
                               in out          ***
END GEN-INFO
*** Section PWATER***

```

ACTIVITY

```

<PLS > ***** Active Sections *****
# - # ATMP SNOW PWAT  SED  PST  PWG PQAL MSTL PEST NITR PHOS TRAC ***
END ACTIVITY

```

PRINT-INFO

```

<PLS > ***** Print-flags ***** PIVL  PYR
# - # ATMP SNOW PWAT  SED  PST  PWG PQAL MSTL PEST NITR PHOS TRAC *****
END PRINT-INFO

```

PWAT-PARM1

```

<PLS > PWATER variable monthly parameter value flags ***
# - # CSNO RTOP UZFG  VCS  VUZ  VNN VIFW VIRC  VLE INFC  HWT ***

```

```

END PWAT-PARM1

PWAT-PARM2
  <PLS >      PWATER input info: Part 2          ***
  # - # ***FOREST      LZSN      INFILT      LSUR      SLSUR      KVARY      AGWRC
END PWAT-PARM2

PWAT-PARM3
  <PLS >      PWATER input info: Part 3          ***
  # - # ***PETMAX      PETMIN      INFEXP      INFILD      DEEPFR      BASETP      AGWETP
END PWAT-PARM3

PWAT-PARM4
  <PLS >      PWATER input info: Part 4          ***
  # - #      CEPSC      UZSN      NSUR      INTFW      IRC      LZETP ***
END PWAT-PARM4

PWAT-STATE1
  <PLS > *** Initial conditions at start of simulation
  ran from 1990 to end of 1992 (pat 1-11-95) RUN 21 ***
  # - # *** CEPS      SURS      UZS      IFWS      LZS      AGWS      GWVS
END PWAT-STATE1

END PERLND

IMPLND
GEN-INFO
  <PLS ><-----Name----->      Unit-systems      Printer ***
  # - #      User      t-series      Engl Metr ***
  in out ***
  1      ROADS/FLAT      1      1      1      27      0
END GEN-INFO
*** Section IWATER***

ACTIVITY
  <PLS > ***** Active Sections *****
  # - # ATMP SNOW IWAT SLD IWG IQAL ***
  1      0      0      1      0      0      0
END ACTIVITY

PRINT-INFO
  <ILS > ***** Print-flags ***** PIVL PYR
  # - # ATMP SNOW IWAT SLD IWG IQAL *****
  1      0      0      4      0      0      4      1      9
END PRINT-INFO

IWAT-PARM1
  <PLS > IWATER variable monthly parameter value flags ***
  # - # CSNO RTOP VRS VNN RTLI ***
  1      0      0      0      0      0
END IWAT-PARM1

IWAT-PARM2
  <PLS >      IWATER input info: Part 2          ***
  # - # *** LSUR      SLSUR      NSUR      RETSC
  1      400      0.01      0.1      0.1
END IWAT-PARM2

IWAT-PARM3
  <PLS >      IWATER input info: Part 3          ***
  # - # ***PETMAX      PETMIN
  1      0      0
END IWAT-PARM3

IWAT-STATE1
  <PLS > *** Initial conditions at start of simulation
  # - # *** RETS      SURS
  1      0      0
END IWAT-STATE1

END IMPLND

```



END EXT SOURCES

EXT TARGETS

```
<-Volume-> <-Grp> <-Member-><--Mult-->Tran <-Volume-> <Member> Tsys Tgap Amd ***  
<Name> # <Name> # #<-factor->strg <Name> # <Name> tem strg strg***  
COPY 501 OUTPUT MEAN 1 1 48.4 WDM 501 FLOW ENGL REPL  
END EXT TARGETS
```

MASS-LINK

```
<Volume> <-Grp> <-Member-><--Mult--> <Target> <-Grp> <-Member->***  
<Name> <Name> # #<-factor-> <Name> <Name> # #***  
MASS-LINK 15  
IMPLND IWATER SURO 0.083333 COPY INPUT MEAN  
END MASS-LINK 15
```

END MASS-LINK

END RUN

*Mitigated UCI File*

RUN

GLOBAL

```

WVHM4 model simulation
START      1948 10 01      END      2009 09 30
RUN INTERP OUTPUT LEVEL   3      0
RESUME     0 RUN          1              UNIT SYSTEM      1
END GLOBAL

```

FILES

```

<File> <Un#> <-----File Name----->***
<-ID->                                     ***
WDM      26      default[10].wdm
MESSU    25      Mitdefault[10].MES
          27      Mitdefault[10].L61
          28      Mitdefault[10].L62
          30      POCdefault[10]1.dat

```

END FILES

OPN SEQUENCE

```

INGRP              INDELT 00:15
  IMPLND           1
  COPY             501
  DISPLY           1
END INGRP

```

END OPN SEQUENCE

DISPLY

```

DISPLY-INF01
# - #<-----Title----->***TRAN PIVL DIG1 FIL1  PYR DIG2 FIL2 YRND
1      Basin 1              MAX              1      2      30      9
END DISPLY-INF01

```

END DISPLY

COPY

```

TIMESERIES
# - # NPT NMN ***
1      1      1
501    1      1
END TIMESERIES

```

END COPY

GENER

```

OPCODE
#      # OPCD ***
END OPCODE
PARM
#      #          K ***
END PARM

```

END GENER

PERLND

```

GEN-INFO
<PLS ><-----Name----->NBLKS  Unit-systems  Printer ***
# - #                               User t-series Engl Metr ***
                               in out          ***
END GEN-INFO
*** Section PWATER***

```

ACTIVITY

```

<PLS > ***** Active Sections *****
# - # ATMP SNOW PWAT  SED  PST  PWG PQAL MSTL PEST NITR PHOS TRAC ***
END ACTIVITY

```

PRINT-INFO

```

<PLS > ***** Print-flags ***** PIVL  PYR
# - # ATMP SNOW PWAT  SED  PST  PWG PQAL MSTL PEST NITR PHOS TRAC *****
END PRINT-INFO

```

PWAT-PARM1

```

<PLS > PWATER variable monthly parameter value flags ***
# - # CSNO RTOP UZFG  VCS  VUZ  VNN VIFW VIRC  VLE INFC  HWT ***

```

```

END PWAT-PARM1

PWAT-PARM2
<PLS > PWATER input info: Part 2 ***
# - # ***FOREST LZSN INFILT LSUR SLSUR KVARY AGWRC
END PWAT-PARM2

PWAT-PARM3
<PLS > PWATER input info: Part 3 ***
# - # ***PETMAX PETMIN INFEXP INFILD DEEPFR BASETP AGWETP
END PWAT-PARM3

PWAT-PARM4
<PLS > PWATER input info: Part 4 ***
# - # CEPSC UZSN NSUR INTFW IRC LZETP ***
END PWAT-PARM4

PWAT-STATE1
<PLS > *** Initial conditions at start of simulation
ran from 1990 to end of 1992 (pat 1-11-95) RUN 21 ***
# - # *** CEPS SURS UZS IFWS LZS AGWS GWVS
END PWAT-STATE1

END PERLND

IMPLND
GEN-INFO
<PLS ><-----Name-----> Unit-systems Printer ***
# - # User t-series Engr Metr ***
in out ***
1 ROADS/FLAT 1 1 1 27 0
END GEN-INFO
*** Section IWATER***

ACTIVITY
<PLS > ***** Active Sections *****
# - # ATMP SNOW IWAT SLD IWG IQAL ***
1 0 0 1 0 0 0
END ACTIVITY

PRINT-INFO
<ILS > ***** Print-flags ***** PIVL PYR
# - # ATMP SNOW IWAT SLD IWG IQAL *****
1 0 0 4 0 0 4 1 9
END PRINT-INFO

IWAT-PARM1
<PLS > IWATER variable monthly parameter value flags ***
# - # CSNO RTOP VRS VNN RTLI ***
1 0 0 0 0 0
END IWAT-PARM1

IWAT-PARM2
<PLS > IWATER input info: Part 2 ***
# - # *** LSUR SLSUR NSUR RETSC
1 400 0.01 0.1 0.1
END IWAT-PARM2

IWAT-PARM3
<PLS > IWATER input info: Part 3 ***
# - # ***PETMAX PETMIN
1 0 0
END IWAT-PARM3

IWAT-STATE1
<PLS > *** Initial conditions at start of simulation
# - # *** RETS SURS
1 0 0
END IWAT-STATE1

END IMPLND

```



END EXT SOURCES

EXT TARGETS

<-Volume->	<-Grp>	<-Member->	<--Mult-->	Tran	<-Volume->	<Member>	Tsys	Tgap	Amd	***	
<Name>	#	<Name>	#	#<-factor->	strg	<Name>	#	<Name>	tem	strg	strg***
COPY	1	OUTPUT	MEAN	1	1	48.4	WDM	701	FLOW	ENGL	REPL
COPY	501	OUTPUT	MEAN	1	1	48.4	WDM	801	FLOW	ENGL	REPL

END EXT TARGETS

MASS-LINK

<Volume>	<-Grp>	<-Member->	<--Mult-->	<Target>	<-Grp>	<-Member->	***
<Name>	#	<Name>	#	#<-factor->	<Name>	#	#***
MASS-LINK		15					
IMPLND	IWATER	SURO		0.083333	COPY	INPUT	MEAN
END MASS-LINK		15					

END MASS-LINK

END RUN

*Predeveloped HSPF Message File*

*Mitigated HSPF Message File*

## *Disclaimer*

### *Legal Notice*

This program and accompanying documentation are provided 'as-is' without warranty of any kind. The entire risk regarding the performance and results of this program is assumed by End User. Clear Creek Solutions Inc. and the governmental licensee or sublicensees disclaim all warranties, either expressed or implied, including but not limited to implied warranties of program and accompanying documentation. In no event shall Clear Creek Solutions Inc. be liable for any damages whatsoever (including without limitation to damages for loss of business profits, loss of business information, business interruption, and the like) arising out of the use of, or inability to use this program even if Clear Creek Solutions Inc. or their authorized representatives have been advised of the possibility of such damages. Software Copyright © by : Clear Creek Solutions, Inc. 2005-2025; All Rights Reserved.

Clear Creek Solutions, Inc.  
6200 Capitol Blvd. Ste F  
Olympia, WA. 98501  
Toll Free 1(866)943-0304  
Local (360)943-0304

[www.clearcreeksolutions.com](http://www.clearcreeksolutions.com)

# **BMP C101: Preserving Natural Vegetation**

## ***Purpose***

The purpose of preserving natural vegetation is to reduce erosion wherever practicable. Limiting site disturbance is the single most effective method for reducing erosion. For example, conifers can hold up to about 50 percent of all rain that falls during a storm. Up to 20-30 percent of this rain may never reach the ground but is taken up by the tree or evaporates. Another benefit is that the rain held in the tree can be released slowly to the ground after the storm.

## ***Conditions of Use***

Natural vegetation should be preserved on steep slopes, near perennial and intermittent water-courses or swales, and on building sites in wooded areas.

- As required by local governments.
- Phase construction to preserve natural vegetation on the project site for as long as possible during the construction period.

## ***Design and Installation Specifications***

Natural vegetation can be preserved in natural clumps or as individual trees, shrubs and vines.

The preservation of individual plants is more difficult because heavy equipment is generally used to remove unwanted vegetation. The points to remember when attempting to save individual plants are:

- Is the plant worth saving? Consider the location, species, size, age, vigor, and the work involved. Local governments may also have ordinances to save natural vegetation and trees.
- Fence or clearly mark areas around trees that are to be saved. It is preferable to keep ground disturbance away from the trees at least as far out as the dripline.

Plants need protection from three kinds of injuries:

- *Construction Equipment* - This injury can be above or below the ground level. Damage results from scarring, cutting of roots, and compaction of the soil. Placing a fenced buffer zone around plants to be saved prior to construction can prevent construction equipment injuries.
- *Grade Changes* - Changing the natural ground level will alter grades, which affects the plant's ability to obtain the necessary air, water, and minerals. Minor fills usually do not cause problems although sensitivity between species does vary and should be checked. Trees can typically tolerate fill of 6 inches or less. For shrubs and other plants, the fill should be less.

When there are major changes in grade, it may become necessary to supply air to the roots of plants. This can be done by placing a layer of gravel and a tile system over the roots before the fill is made. The tile system should be laid out on the original grade leading from a dry well

around the tree trunk. The system should then be covered with small stones to allow air to circulate over the root area.

Lowering the natural ground level can seriously damage trees and shrubs. The highest percentage of the plant roots are in the upper 12 inches of the soil and cuts of only 2-3 inches can cause serious injury. To protect the roots it may be necessary to terrace the immediate area around the plants to be saved. If roots are exposed, construction of retaining walls may be needed to keep the soil in place. Plants can also be preserved by leaving them on an undisturbed, gently sloping mound. To increase the chances for survival, it is best to limit grade changes and other soil disturbances to areas outside the dripline of the plant.

- *Excavations* - Protect trees and other plants when excavating for drainfields, power, water, and sewer lines. Where possible, the trenches should be routed around trees and large shrubs. When this is not possible, it is best to tunnel under them. This can be done with hand tools or with power augers. If it is not possible to route the trench around plants to be saved, then the following should be observed:
  - Cut as few roots as possible. When you have to cut, cut clean. Paint cut root ends with a wood dressing like asphalt base paint if roots will be exposed for more than 24-hours.
  - Backfill the trench as soon as possible.
  - Tunnel beneath root systems as close to the center of the main trunk to preserve most of the important feeder roots.

Some problems that can be encountered with a few specific trees are:

- Maple, Dogwood, Red alder, Western hemlock, Western red cedar, and Douglas fir do not readily adjust to changes in environment and special care should be taken to protect these trees.
- The windthrow hazard of Pacific silver fir and madrona is high, while that of Western hemlock is moderate. The danger of windthrow increases where dense stands have been thinned. Other species (unless they are on shallow, wet soils less than 20 inches deep) have a low windthrow hazard.
- Cottonwoods, maples, and willows have water-seeking roots. These can cause trouble in sewer lines and infiltration fields. On the other hand, they thrive in high moisture conditions that other trees would not.
- Thinning operations in pure or mixed stands of Grand fir, Pacific silver fir, Noble fir, Sitka spruce, Western red cedar, Western hemlock, Pacific dogwood, and Red alder can cause serious disease problems. Disease can become established through damaged limbs, trunks, roots, and freshly cut stumps. Diseased and weakened trees are also susceptible to insect attack.

## ***Maintenance Standards***

Inspect flagged and/or fenced areas regularly to make sure flagging or fencing has not been removed or damaged. If the flagging or fencing has been damaged or visibility reduced, it shall be repaired or replaced immediately and visibility restored.

If tree roots have been exposed or injured, “prune” cleanly with an appropriate pruning saw or loppers directly above the damaged roots and recover with native soils. Treatment of sap flowing trees (fir, hemlock, pine, soft maples) is not advised as sap forms a natural healing barrier.

## **BMP C125: Topsoiling / Composting**

### ***Purpose***

Topsoiling and composting provide a suitable growth medium for final site stabilization with vegetation. While not a permanent cover practice in itself, topsoiling and composting are an integral component of providing permanent cover in those areas where there is an unsuitable soil surface for plant growth. Use this BMP in conjunction with other BMPs such as [BMP C120: Temporary and Permanent Seeding](#), [BMP C121: Mulching](#), or [BMP C124: Sodding](#). Implementation of this BMP may meet the post-construction requirements of [BMP T5.13: Post-Construction Soil Quality and Depth](#).

Native soils and disturbed soils that have been organically amended not only retain much more stormwater, but also serve as effective biofilters for urban pollutants and, by supporting more vigorous plant growth, reduce the water, fertilizer and pesticides needed to support installed landscapes. Topsoil does not include any subsoils but only the material from the top several inches including organic debris.

### ***Conditions of Use***

- Permanent landscaped areas shall contain healthy topsoil that reduces the need for fertilizers, improves overall topsoil quality, provides for better vegetative health and vitality, improves hydrologic characteristics, and reduces the need for irrigation.
- Leave native soils and the duff layer undisturbed to the maximum extent practicable. Stripping of existing, properly functioning soil system and vegetation for the purpose of topsoiling during construction is not acceptable. Preserve existing soil systems in undisturbed and uncompacted conditions if functioning properly.
- Areas that already have good topsoil, such as undisturbed areas, do not require soil amendments.
- Restore, to the maximum extent practical, native soils disturbed during clearing and grading to a condition equal to or better than the original site condition's moisture-holding capacity. Use on-site native topsoil, incorporate amendments into on-site soil, or import blended topsoil to meet this requirement.
- Topsoiling is a required procedure when establishing vegetation on shallow soils, and soils of critically low pH (high acid) levels.
- Beware of where the topsoil comes from, and what vegetation was on site before disturbance. Invasive plant seeds may be included and could cause problems for establishing native plants, landscaped areas, or grasses.
- Topsoil from the site will contain mycorrhizal bacteria that are necessary for healthy root growth and nutrient transfer. These native mycorrhiza are acclimated to the site and will provide optimum conditions for establishing grasses. Use commercially available mycorrhiza products when using off-site topsoil.

## ***Design and Installation Specifications***

Meet the following requirements for disturbed areas that will be developed as lawn or landscaped areas at the completed project site:

- Maximize the depth of the topsoil wherever possible to provide the maximum possible infiltration capacity and beneficial growth medium. Topsoil shall have:
  - A minimum depth of 8-inches. Scarify subsoils below the topsoil layer at least 4-inches with some incorporation of the upper material to avoid stratified layers, where feasible. Ripping or re-structuring the subgrade may also provide additional benefits regarding the overall infiltration and interflow dynamics of the soil system.
  - A minimum organic content of 10% dry weight in planting beds, and 5% organic matter content in turf areas. Incorporate organic amendments to a minimum 8-inch depth except where tree roots or other natural features limit the depth of incorporation.
  - A pH between 6.0 and 8.0 or matching the pH of the undisturbed soil.
  - If blended topsoil is imported, then fines should be limited to 25 percent passing through a 200 sieve.
- Mulch planting beds with 2 inches of organic material
- Accomplish the required organic content, depth, and pH by returning native topsoil to the site, importing topsoil of sufficient organic content, and/or incorporating organic amendments. When using the option of incorporating amendments to meet the organic content requirement, use compost that meets the compost specification for Bioretention (See [BMP T7.30: Bioretention](#)), with the exception that the compost may have up to 35% biosolids or manure.
- Sections 3 through 7 of *Building Soil: Guidelines and Resources for Implementing Soil Quality and Depth BMP T5.13 in WDOE Stormwater Management Manual for Western Washington* ([Stenn et al., 2016](#)), provides useful guidance for implementing whichever option is chosen. It includes guidance for pre-approved default strategies and guidance for custom strategies. Check with your local jurisdiction concerning its acceptance of this guidance.
- The final composition and construction of the soil system will result in a natural selection or favoring of certain plant species over time. For example, incorporation of topsoil may favor grasses, while layering with mildly acidic, high-carbon amendments may favor more woody vegetation.
- Allow sufficient time in scheduling for topsoil spreading prior to seeding, sodding, or planting.
- Take care when applying top soil to subsoils with contrasting textures. Sandy topsoil over clayey subsoil is a particularly poor combination, as water creeps along the junction between the soil layers and causes the topsoil to slough. If topsoil and subsoil are not properly bonded, water will not infiltrate the soil profile evenly and it will be difficult to establish vegetation. The best method to promote bonding is to actually work the topsoil into the layer below for a depth of at least 6 inches.
- Field exploration of the site shall be made to determine if there is surface soil of sufficient quantity and quality to justify stripping. Topsoil shall be friable and loamy (loam, sandy loam,

silt loam, sandy clay loam, and clay loam). Avoid areas of natural ground water recharge.

- Stripping shall be confined to the immediate construction area. A 4-inch to 6-inch stripping depth is common, but depth may vary depending on the particular soil. All surface runoff control structures shall be in place prior to stripping.
- Do not place topsoil while in a frozen or muddy condition, when the subgrade is excessively wet, or when conditions exist that may otherwise be detrimental to proper grading or proposed sodding or seeding.
- In any areas requiring grading, remove and stockpile the duff layer and topsoil on site in a designated, controlled area, not adjacent to public resources and critical areas. Reapply stockpiled topsoil to other portions of the site where feasible.
- Locate the topsoil stockpile so that it meets specifications and does not interfere with work on the site. It may be possible to locate more than one pile in proximity to areas where topsoil will be used.
- Stockpiling of topsoil shall occur in the following manner:
  - Side slopes of the stockpile shall not exceed 2H:1V.
  - Between October 1 and April 30:
    - An interceptor dike with gravel outlet and silt fence shall surround all topsoil.
    - Within 2 days complete erosion control seeding, or covering stockpiles with clear plastic, or other mulching materials.
  - Between May 1 and September 30:
    - An interceptor dike with gravel outlet and silt fence shall surround all topsoil if the stockpile will remain in place for a longer period of time than active construction grading.
    - Within 7 days complete erosion control seeding, or covering stockpiles with clear plastic, or other mulching materials.
- When native topsoil is to be stockpiled and reused the following should apply to ensure that the mycorrhizal bacterial, earthworms, and other beneficial organisms will not be destroyed:
  - Re-install topsoil within 4 to 6 weeks.
  - Do not allow the saturation of topsoil with water.
  - Do not use plastic covering.

## ***Maintenance Standards***

- Inspect stockpiles regularly, especially after large storm events. Stabilize any areas that have eroded.
- Establish soil quality and depth toward the end of construction and once established, protect from compaction, such as from large machinery use, and from erosion.

- Plant and mulch soil after installation.
- Leave plant debris or its equivalent on the soil surface to replenish organic matter.
- Reduce and adjust, where possible, the use of irrigation, fertilizers, herbicides and pesticides, rather than continuing to implement formerly established practices.

## **BMP C151: Concrete Handling**

### ***Purpose***

Concrete work can generate process water and slurry that contain fine particles and high pH, both of which can violate water quality standards in the receiving water. Concrete spillage or concrete discharge to waters of the State is prohibited. Use this BMP to minimize and eliminate concrete, concrete process water, and concrete slurry from entering waters of the State.

## Conditions of Use

Any time concrete is used, utilize these management practices. Concrete construction project components include, but are not limited to:

- Curbs
- Sidewalks
- Roads
- Bridges
- Foundations
- Floors
- Runways

Disposal options for concrete, in order of preference are:

1. Off-site disposal
2. Concrete wash-out areas (see [BMP C154: Concrete Washout Area](#))
3. De minimus washout to formed areas awaiting concrete

## Design and Installation Specifications

- Wash concrete truck drums at an approved off-site location or in designated concrete washout areas only. Do not wash out concrete trucks onto the ground (including formed areas awaiting concrete), or into storm drains, open ditches, streets, or streams. Refer to [BMP C154: Concrete Washout Area](#) for information on concrete washout areas.
  - Return unused concrete remaining in the truck and pump to the originating batch plant for recycling. Do not dump excess concrete on site, except in designated concrete washout areas as allowed in [BMP C154: Concrete Washout Area](#).
- Wash small concrete handling equipment (e.g. hand tools, screeds, shovels, rakes, floats, trowels, and wheelbarrows) into designated concrete washout areas or into formed areas awaiting concrete pour.
- At no time shall concrete be washed off into the footprint of an area where an infiltration feature will be installed.
- Wash equipment difficult to move, such as concrete paving machines, in areas that do not directly drain to natural or constructed stormwater conveyance or potential infiltration areas.
- Do not allow washwater from areas, such as concrete aggregate driveways, to drain directly (without detention or treatment) to natural or constructed stormwater conveyances.
- Contain washwater and leftover product in a lined container when no designated concrete washout areas (or formed areas, allowed as described above) are available. Dispose of contained concrete and concrete washwater (process water) properly.

- Always use forms or solid barriers for concrete pours, such as pilings, within 15-feet of surface waters.
- Refer to [BMP C252: Treating and Disposing of High pH Water](#) for pH adjustment requirements.
- Refer to the Construction Stormwater General Permit (CSWGP) for pH monitoring requirements if the project involves one of the following activities:
  - Significant concrete work (as defined in the CSWGP).
  - The use of soils amended with (but not limited to) Portland cement-treated base, cement kiln dust or fly ash.
  - Discharging stormwater to segments of water bodies on the 303(d) list (Category 5) for high pH.

### ***Maintenance Standards***

Check containers for holes in the liner daily during concrete pours and repair the same day.

## **BMP C209: Outlet Protection**

### ***Purpose***

Outlet protection prevents scour at conveyance outlets and minimizes the potential for downstream erosion by reducing the velocity of concentrated stormwater flows.

### ***Conditions of Use***

Use outlet protection at the outlets of all ponds, pipes, ditches, or other conveyances that discharge to a natural or manmade drainage feature such as a stream, wetland, lake, or ditch.

### ***Design and Installation Specifications***

- The receiving channel at the outlet of a pipe shall be protected from erosion by lining a minimum of 6 feet downstream and extending up the channel sides a minimum of 1-foot above the maximum tailwater elevation, or 1-foot above the crown, whichever is higher. For pipes larger than 18 inches in diameter, the outlet protection lining of the channel shall be four times the diameter of the outlet pipe.
- Standard wingwalls, tapered outlets, and paved channels should also be considered when appropriate for permanent culvert outlet protection ([WSDOT, 2015](#)).
- [BMP C122: Nets and Blankets](#) or [BMP C202: Riprap Channel Lining](#) provide suitable options for lining materials.
- With low flows, [BMP C201: Grass-Lined Channels](#) can be an effective alternative for lining material.
- The following guidelines shall be used for outlet protection with riprap:
  - If the discharge velocity at the outlet is less than 5 fps, use 2-inch to 8-inch riprap. Minimum thickness is 1-foot.
  - For 5 to 10 fps discharge velocity at the outlet, use 24-inch to 48-inch riprap. Minimum

thickness is 2 feet.

- For outlets at the base of steep slope pipes (pipe slope greater than 10 percent), use an engineered energy dissipator.
- Filter fabric or erosion control blankets should always be used under riprap to prevent scour and channel erosion. See [BMP C122: Nets and Blankets](#).
- Bank stabilization, bioengineering, and habitat features may be required for disturbed areas. This work may require a Hydraulic Project Approval (HPA) from the Washington State Department of Fish and Wildlife. See [I-2.11 Hydraulic Project Approvals](#).

### ***Maintenance Standards***

- Inspect and repair as needed.
- Add rock as needed to maintain the intended function.
- Clean energy dissipator if sediment builds up.

## **BMP C220: Inlet Protection**

### ***Purpose***

Inlet protection prevents coarse sediment from entering drainage systems prior to permanent stabilization of the disturbed area.

### ***Conditions of Use***

Use inlet protection at inlets that are operational before permanent stabilization of the disturbed areas that contribute runoff to the inlet. Provide protection for all storm drain inlets downslope and within 500 feet of a disturbed or construction area, unless those inlets are preceded by a sediment trapping BMP.

Also consider inlet protection for lawn and yard drains on new home construction. These small and numerous drains coupled with lack of gutters can add significant amounts of sediment into the roof drain system. If possible, delay installing lawn and yard drains until just before landscaping, or cap these drains to prevent sediment from entering the system until completion of landscaping. Provide 18-inches of sod around each finished lawn and yard drain.

[Table II-3.10: Storm Drain Inlet Protection](#) lists several options for inlet protection. All of the methods for inlet protection tend to plug and require a high frequency of maintenance. Limit contributing drainage areas for an individual inlet to one acre or less. If possible, provide emergency overflows with additional end-of-pipe treatment where stormwater ponding would cause a hazard.

**Table II-3.10: Storm Drain Inlet Protection**

Type of Inlet Protection	Emergency Overflow	Applicable for Paved/ Earthen Surfaces	Conditions of Use
<b>Drop Inlet Protection</b>			
Excavated drop inlet protection	Yes, temporary flooding may occur	Earthen	Applicable for heavy flows. Easy to maintain. Large area requirement: 30'x30'/acre
Block and gravel drop inlet protection	Yes	Paved or Earthen	Applicable for heavy concentrated flows. Will not pond.
Gravel and wire drop inlet protection	No	Paved or Earthen	Applicable for heavy concentrated flows. Will pond. Can withstand traffic.
Catch basin filters	Yes	Paved or Earthen	Frequent maintenance required.
<b>Curb Inlet Protection</b>			
Curb inlet protection with wooden weir	Small capacity overflow	Paved	Used for sturdy, more compact installation.
Block and gravel curb inlet protection	Yes	Paved	Sturdy, but limited filtration.
<b>Culvert Inlet Protection</b>			
Culvert inlet sediment trap	N/A	N/A	18 month expected life.

## ***Design and Installation Specifications***

### **Excavated Drop Inlet Protection**

Excavated drop inlet protection consists of an excavated impoundment around the storm drain inlet. Sediment settles out of the stormwater prior to entering the storm drain. Design and installation specifications for excavated drop inlet protection include:

- Provide a depth of 1-2 ft as measured from the crest of the inlet structure.
- Slope sides of excavation should be no steeper than 2H:1V.
- Minimum volume of excavation is 35 cubic yards.
- Shape the excavation to fit the site, with the longest dimension oriented toward the longest inflow area.
- Install provisions for draining to prevent standing water.
- Clear the area of all debris.

- Grade the approach to the inlet uniformly.
- Drill weep holes into the side of the inlet.
- Protect weep holes with screen wire and washed aggregate.
- Seal weep holes when removing structure and stabilizing area.
- Build a temporary dike, if necessary, to the down slope side of the structure to prevent bypass flow.

### **Block and Gravel Filter**

A block and gravel filter is a barrier formed around the inlet with standard concrete blocks and gravel. See [Figure II-3.17: Block and Gravel Filter](#). Design and installation specifications for block gravel filters include:

- Provide a height of 1 to 2 feet above the inlet.
- Recess the first row of blocks 2-inches into the ground for stability.
- Support subsequent courses by placing a pressure treated wood 2x4 through the block opening.
- Do not use mortar.
- Lay some blocks in the bottom row on their side to allow for dewatering the pool.
- Place hardware cloth or comparable wire mesh with ½-inch openings over all block openings.
- Place gravel to just below the top of blocks on slopes of 2H:1V or flatter.
- An alternative design is a gravel berm surrounding the inlet, as follows:
  - Provide a slope of 3H:1V on the upstream side of the berm.
  - Provide a slope of 2H:1V on the downstream side of the berm.
  - Provide a 1-foot wide level stone area between the gravel berm and the inlet.
  - Use stones 3 inches in diameter or larger on the upstream slope of the berm.
  - Use gravel ½- to ¾-inch at a minimum thickness of 1-foot on the downstream slope of the berm.

**Figure II-3.17: Block and Gravel Filter**

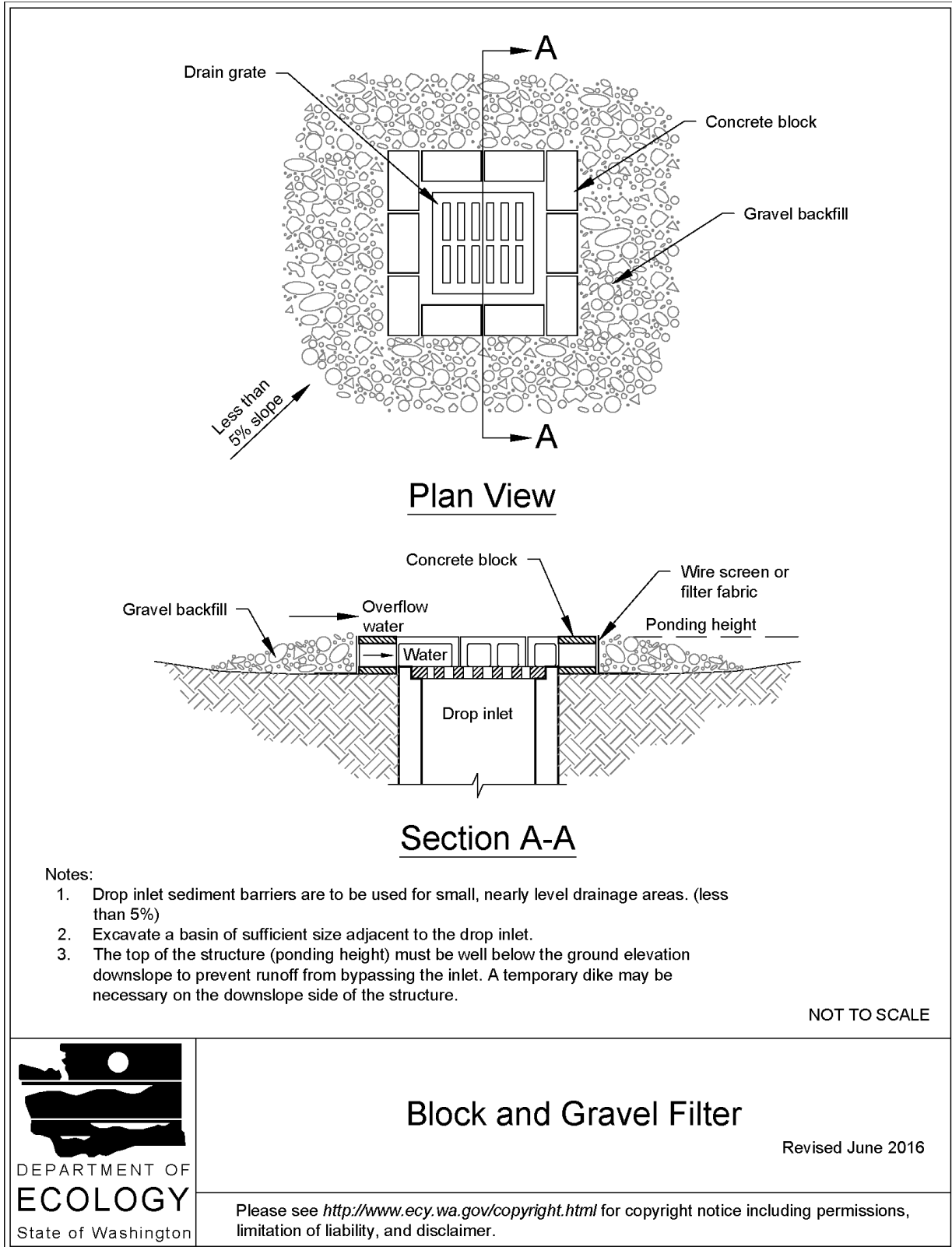

### **Gravel and Wire Mesh Filter**

Gravel and wire mesh filters are gravel barriers placed over the top of the inlet. This method does not provide an overflow. Design and installation specifications for gravel and wire mesh filters include:

- Use a hardware cloth or comparable wire mesh with ½-inch openings.
  - Place wire mesh over the drop inlet so that the wire extends a minimum of 1-foot beyond each side of the inlet structure.
  - Overlap the strips if more than one strip of mesh is necessary.
- Place coarse aggregate over the wire mesh.
  - Provide at least a 12-inch depth of aggregate over the entire inlet opening and extend at least 18-inches on all sides.

### **Catch Basin Filters**

Catch basin filters are designed by manufacturers for construction sites. The limited sediment storage capacity increases the amount of inspection and maintenance required, which may be daily for heavy sediment loads. To reduce maintenance requirements, combine a catch basin filter with another type of inlet protection. This type of inlet protection provides flow bypass without overflow and therefore may be a better method for inlets located along active rights-of-way. Design and installation specifications for catch basin filters include:

- Provides 5 cubic feet of storage.
- Requires dewatering provisions.
- Provides a high-flow bypass that will not clog under normal use at a construction site.
- Insert the catch basin filter in the catch basin just below the grating.

### **Curb Inlet Protection with Wooden Weir**

Curb inlet protection with wooden weir is an option that consists of a barrier formed around a curb inlet with a wooden frame and gravel. Design and installation specifications for curb inlet protection with wooden weirs include:

- Use wire mesh with ½-inch openings.
- Use extra strength filter cloth.
- Construct a frame.
- Attach the wire and filter fabric to the frame.
- Pile coarse washed aggregate against the wire and fabric.
- Place weight on the frame anchors.

### **Block and Gravel Curb Inlet Protection**

Block and gravel curb inlet protection is a barrier formed around a curb inlet with concrete blocks and gravel. See [Figure II-3.18: Block and Gravel Curb Inlet Protection](#). Design and installation specifications for block and gravel curb inlet protection include:

- Use wire mesh with ½-inch openings.
- Place two concrete blocks on their sides abutting the curb at either side of the inlet opening. These are spacer blocks.
- Place a 2x4 stud through the outer holes of each spacer block to align the front blocks.
- Place blocks on their sides across the front of the inlet and abutting the spacer blocks.
- Place wire mesh over the outside vertical face.
- Pile coarse aggregate against the wire to the top of the barrier.

**Figure II-3.18: Block and Gravel Curb Inlet Protection**

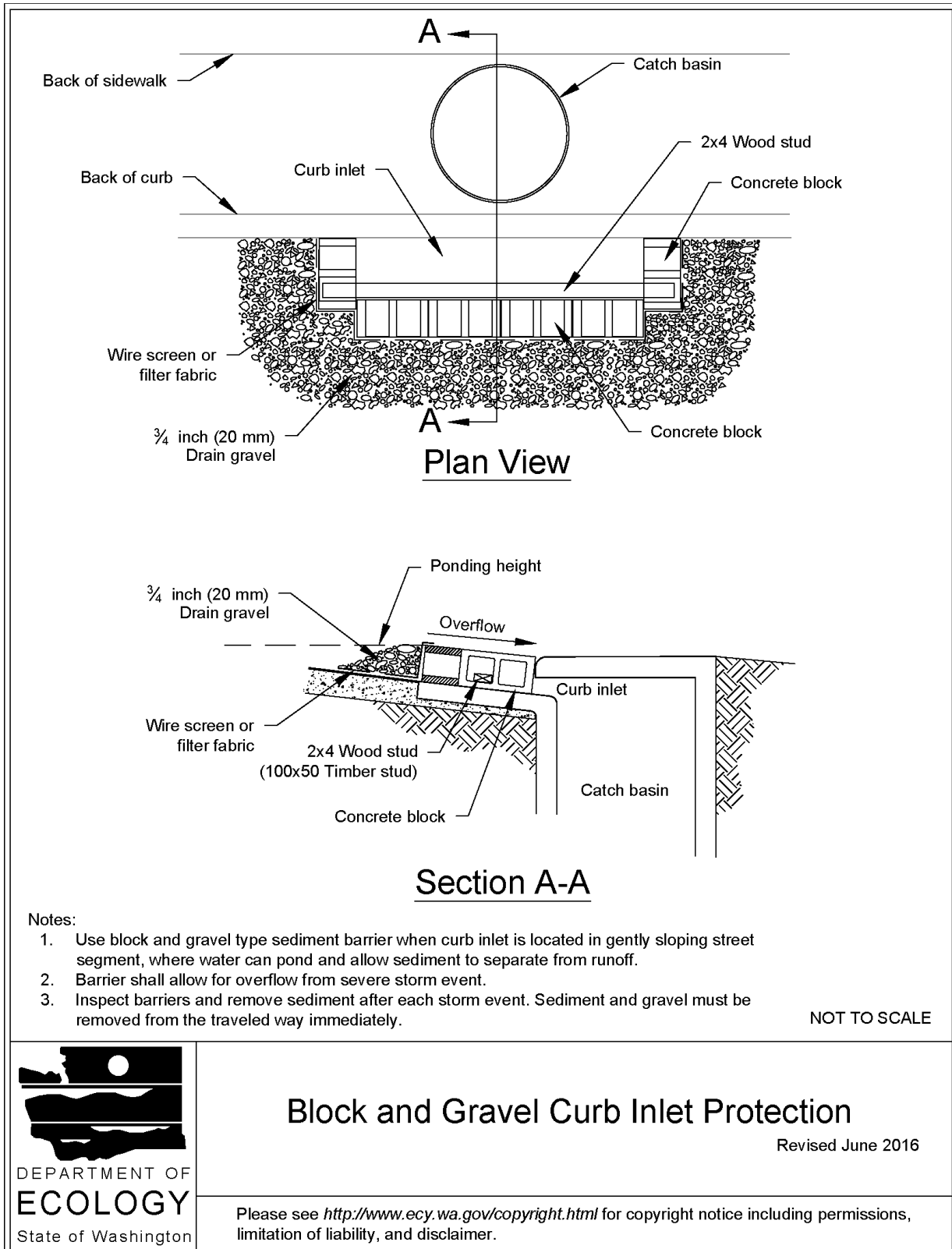

### **Curb and Gutter Sediment Barrier**

Curb and gutter sediment barrier is a sandbag or rock berm (riprap and aggregate) 3 feet high and 3 feet wide in a horseshoe shape. See [Figure II-3.19: Curb and Gutter Barrier](#). Design and installation specifications for curb and gutter sediment barrier include:

- Construct a horseshoe shaped berm, faced with coarse aggregate if using riprap, 3 feet high and 3 feet wide, at least 2 feet from the inlet.
- Construct a horseshoe shaped sedimentation trap on the upstream side of the berm. Size the trap to sediment trap standards for protecting a culvert inlet.

**Figure II-3.19: Curb and Gutter Barrier**

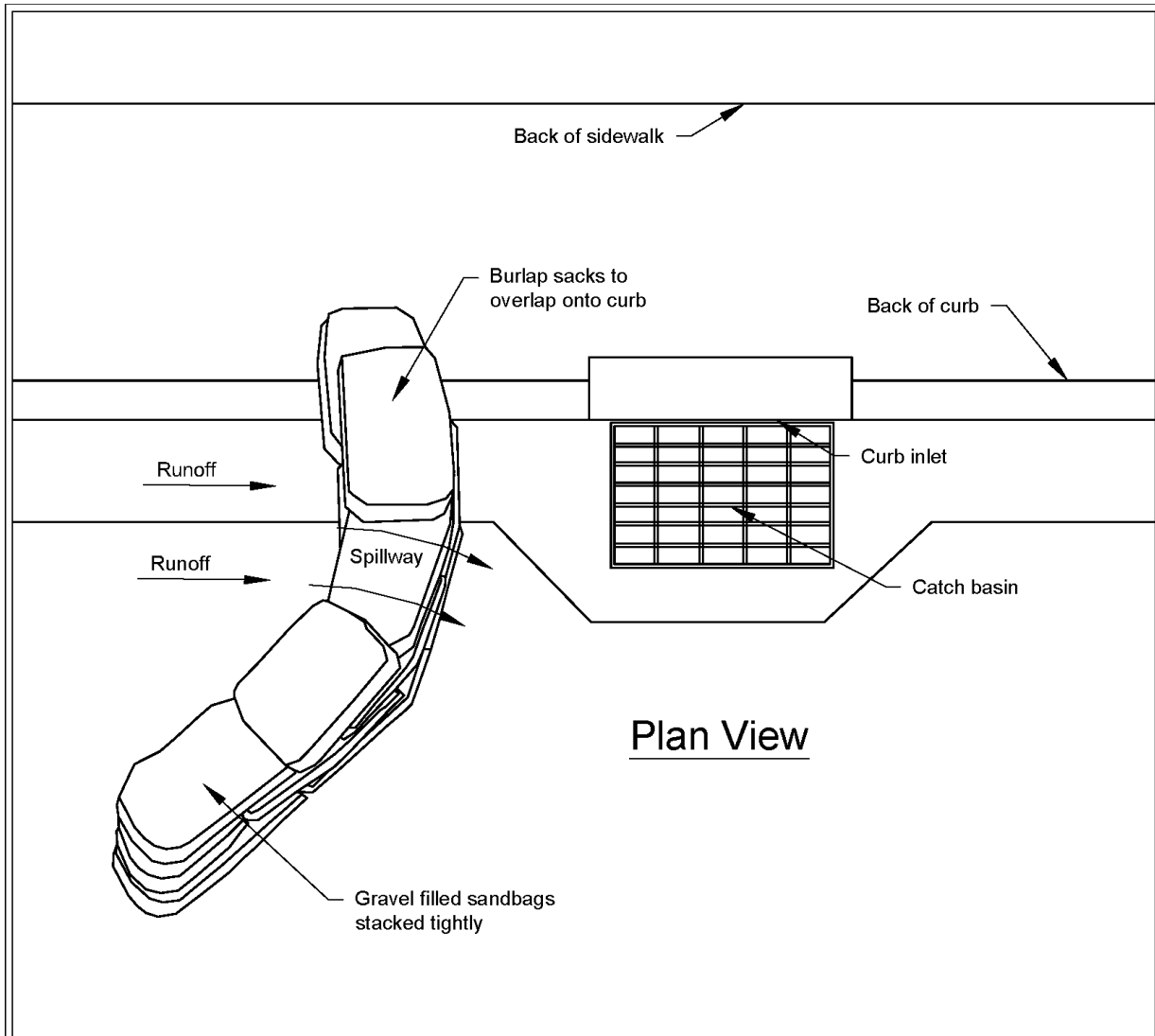

Plan View

**Notes:**

1. Place curb type sediment barriers on gently sloping street segments, where water can pond and allow sediment to separate from runoff.
2. Sandbags of either burlap or woven 'geotextile' fabric, are filled with gravel, layered and packed tightly.
3. Leave a one sandbag gap in the top row to provide a spillway for overflow.
4. Inspect barriers and remove sediment after each storm event. Sediment and gravel must be removed from the traveled way immediately.

NOT TO SCALE



**Curb and Gutter Barrier**

Revised June 2016

Please see <http://www.ecy.wa.gov/copyright.html> for copyright notice including permissions, limitation of liability, and disclaimer.

## ***Maintenance Standards***

- Inspect all forms of inlet protection frequently, especially after storm events. Clean and replace clogged catch basin filters. For rock and gravel filters, pull away the rocks from the inlet and clean or replace. An alternative approach would be to use the clogged rock as fill and put fresh rock around the inlet.
- Do not wash sediment into storm drains while cleaning. Spread all excavated material evenly over the surrounding land area or stockpile and stabilize as appropriate.

## ***Approved as Functionally Equivalent***

Ecology has approved products as able to meet the requirements of this BMP. The products did not pass through the Technology Assessment Protocol – Ecology (TAPE) process. Local jurisdictions may choose not to accept these products, or may require additional testing prior to consideration for local use. Products that Ecology has approved as functionally equivalent are available for review on Ecology's website at:

<https://ecology.wa.gov/Regulations-Permits/Guidance-technical-assistance/Stormwater-permittee-guidance-resources/Emerging-stormwater-treatment-technologies>

## **BMP C233: Silt Fence**

### ***Purpose***

Silt fence reduces the transport of coarse sediment from a construction site by providing a temporary physical barrier to sediment and reducing the runoff velocities of overland flow.

### ***Conditions of Use***

Silt fence may be used downslope of all disturbed areas.

- Silt fence shall prevent sediment carried by runoff from going beneath, through, or over the top of the silt fence, but shall allow the water to pass through the fence.
- Silt fence is not intended to treat concentrated flows, nor is it intended to treat substantial amounts of overland flow. Convey any concentrated flows through the drainage system to a sediment trapping BMP.
- Do not construct silt fences in streams or use in V-shaped ditches. Silt fences do not provide an adequate method of silt control for anything deeper than sheet or overland flow.

**Figure II-3.22: Silt Fence**

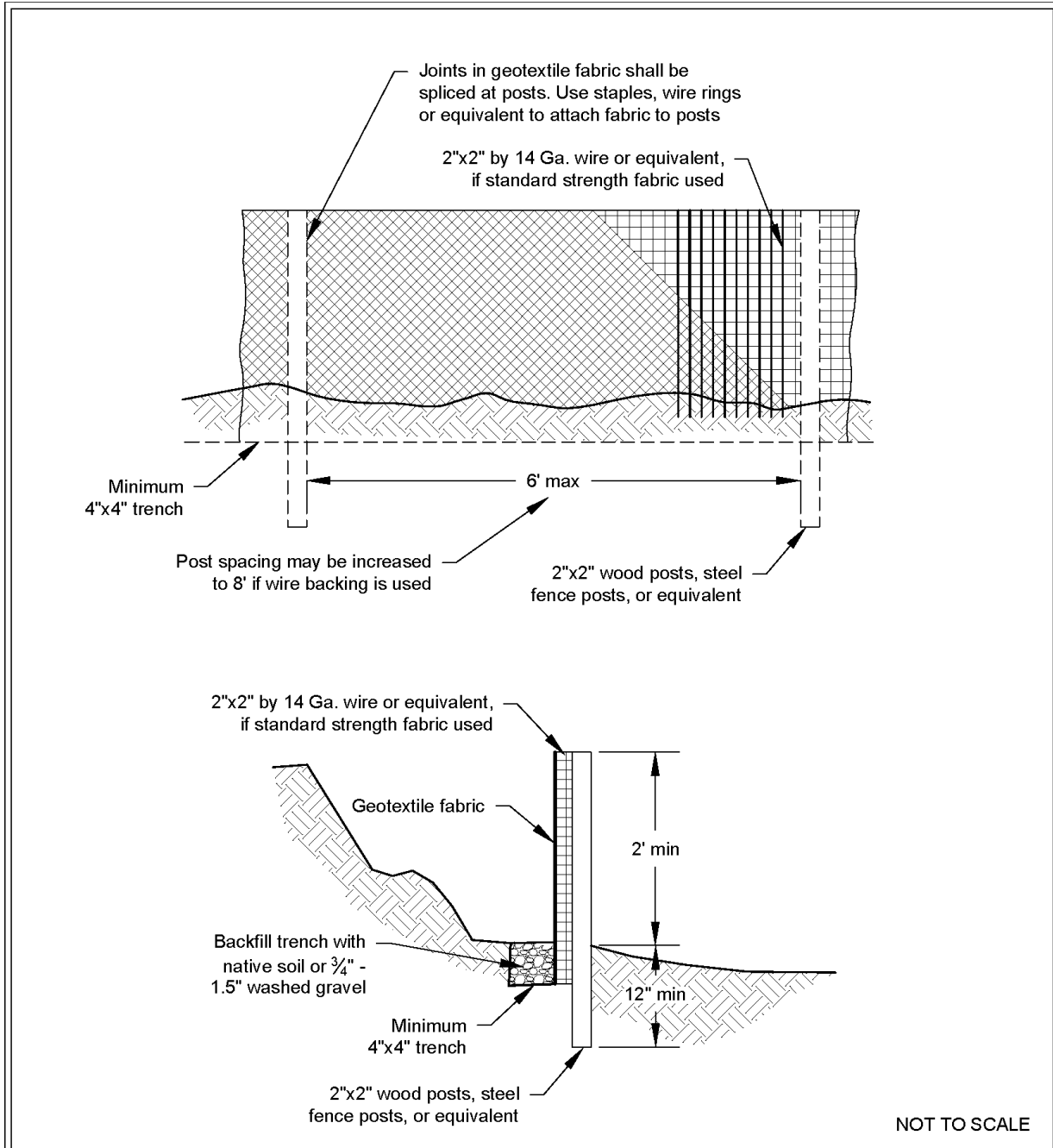

**Silt Fence**

Revised July 2017

Please see <http://www.ecy.wa.gov/copyright.html> for copyright notice including permissions, limitation of liability, and disclaimer.

## Design and Installation Specifications

- Use in combination with other construction stormwater BMPs.
- Maximum slope steepness (perpendicular to the silt fence line) 1H:1V.
- Maximum sheet or overland flow path length to the silt fence of 100 feet.
- Do not allow flows greater than 0.5 cfs.
- Use geotextile fabric that meets the following standards. All geotextile properties listed below are minimum average roll values (i.e., the test result for any sampled roll in a lot shall meet or exceed the values shown in [Table II-3.11: Geotextile Fabric Standards for Silt Fence](#)):

**Table II-3.11: Geotextile Fabric Standards for Silt Fence**

Geotextile Property	Minimum Average Roll Value
Polymeric Mesh AOS (ASTM D4751)	0.60 mm maximum for slit film woven (#30 sieve). 0.30 mm maximum for all other geotextile types (#50 sieve). 0.15 mm minimum for all fabric types (#100 sieve).
Water Permittivity (ASTM D4491)	0.02 sec <sup>-1</sup> minimum
Grab Tensile Strength (ASTM D4632)	180 lbs. Minimum for extra strength fabric. 100 lbs minimum for standard strength fabric.
Grab Tensile Strength (ASTM D4632)	30% maximum
Ultraviolet Resistance (ASTM D4355)	70% minimum

- Support standard strength geotextiles with wire mesh, chicken wire, 2-inch x 2-inch wire, safety fence, or jute mesh to increase the strength of the geotextile. Silt fence materials are available that have synthetic mesh backing attached.
- Silt fence material shall contain ultraviolet ray inhibitors and stabilizers to provide a minimum of six months of expected usable construction life at a temperature range of 0°F to 120°F.
- One-hundred percent biodegradable silt fence is available that is strong, long lasting, and can be left in place after the project is completed, if permitted by the local jurisdiction.
- Refer to [Figure II-3.22: Silt Fence](#) for standard silt fence details. Include the following Standard Notes for silt fence on construction plans and specifications:
  1. The Contractor shall install and maintain temporary silt fences at the locations shown in the Plans.
  2. Construct silt fences in areas of clearing, grading, or drainage prior to starting those activities.

3. The silt fence shall have a 2-foot min. and a 2½-foot max. height above the original ground surface.
4. The geotextile fabric shall be sewn together at the point of manufacture to form fabric lengths as required. Locate all sewn seams at support posts. Alternatively, two sections of silt fence can be overlapped, provided that the overlap is long enough and that the adjacent silt fence sections are close enough together to prevent silt laden water from escaping through the fence at the overlap.
5. Attach the geotextile fabric on the up-slope side of the posts and secure with staples, wire, or in accordance with the manufacturer's recommendations. Attach the geotextile fabric to the posts in a manner that reduces the potential for tearing.
6. Support the geotextile fabric with wire or plastic mesh, dependent on the properties of the geotextile selected for use. If wire or plastic mesh is used, fasten the mesh securely to the up-slope side of the posts with the geotextile fabric up-slope of the mesh.
7. Mesh support, if used, shall consist of steel wire with a maximum mesh spacing of 2-inches, or a prefabricated polymeric mesh. The strength of the wire or polymeric mesh shall be equivalent to or greater than 180 lbs. grab tensile strength. The polymeric mesh must be as resistant to the same level of ultraviolet radiation as the geotextile fabric it supports.
8. Bury the bottom of the geotextile fabric 4-inches min. below the ground surface. Backfill and tamp soil in place over the buried portion of the geotextile fabric, so that no flow can pass beneath the silt fence and scouring cannot occur. When wire or polymeric back-up support mesh is used, the wire or polymeric mesh shall extend into the ground 3-inches min.
9. Drive or place the silt fence posts into the ground 18-inches min. A 12-inch min. depth is allowed if topsoil or other soft subgrade soil is not present and 18-inches cannot be reached. Increase fence post min. depths by 6 inches if the fence is located on slopes of 3H:1V or steeper and the slope is perpendicular to the fence. If required post depths cannot be obtained, the posts shall be adequately secured by bracing or guying to prevent overturning of the fence due to sediment loading.
10. Use wood, steel or equivalent posts. The spacing of the support posts shall be a maximum of 6-feet. Posts shall consist of either:
  - Wood with minimum dimensions of 2 inches by 2 inches by 3 feet. Wood shall be free of defects such as knots, splits, or gouges.
  - No. 6 steel rebar or larger.
  - ASTM A 120 steel pipe with a minimum diameter of 1-inch.
  - U, T, L, or C shape steel posts with a minimum weight of 1.35 lbs./ft.
  - Other steel posts having equivalent strength and bending resistance to the post sizes listed above.
11. Locate silt fences on contour as much as possible, except at the ends of the fence,

where the fence shall be turned uphill such that the silt fence captures the runoff water and prevents water from flowing around the end of the fence.

12. If the fence must cross contours, with the exception of the ends of the fence, place check dams perpendicular to the back of the fence to minimize concentrated flow and erosion. The slope of the fence line where contours must be crossed shall not be steeper than 3H:1V.
  - Check dams shall be approximately 1-foot deep at the back of the fence. Check dams shall be continued perpendicular to the fence at the same elevation until the top of the check dam intercepts the ground surface behind the fence.
  - Check dams shall consist of crushed surfacing base course, gravel backfill for walls, or shoulder ballast. Check dams shall be located every 10 feet along the fence where the fence must cross contours.
- Refer to [Figure II-3.23: Silt Fence Installation by Slicing Method](#) for slicing method details. The following are specifications for silt fence installation using the slicing method:
  1. The base of both end posts must be at least 2- to 4-inches above the top of the geotextile fabric on the middle posts for ditch checks to drain properly. Use a hand level or string level, if necessary, to mark base points before installation.
  2. Install posts 3- to 4-feet apart in critical retention areas and 6- to 7-feet apart in standard applications.
  3. Install posts 24-inches deep on the downstream side of the silt fence, and as close as possible to the geotextile fabric, enabling posts to support the geotextile fabric from upstream water pressure.
  4. Install posts with the nipples facing away from the geotextile fabric.
  5. Attach the geotextile fabric to each post with three ties, all spaced within the top 8-inches of the fabric. Attach each tie diagonally 45 degrees through the fabric, with each puncture at least 1-inch vertically apart. Each tie should be positioned to hang on a post nipple when tightening to prevent sagging.
  6. Wrap approximately 6-inches of the geotextile fabric around the end posts and secure with 3 ties.
  7. No more than 24-inches of a 36-inch geotextile fabric is allowed above ground level.
  8. Compact the soil immediately next to the geotextile fabric with the front wheel of the tractor, skid steer, or roller exerting at least 60 pounds per square inch. Compact the upstream side first and then each side twice for a total of four trips. Check and correct the silt fence installation for any deviation before compaction. Use a flat-bladed shovel to tuck the fabric deeper into the ground if necessary.

**Figure II-3.23: Silt Fence Installation by Slicing Method**

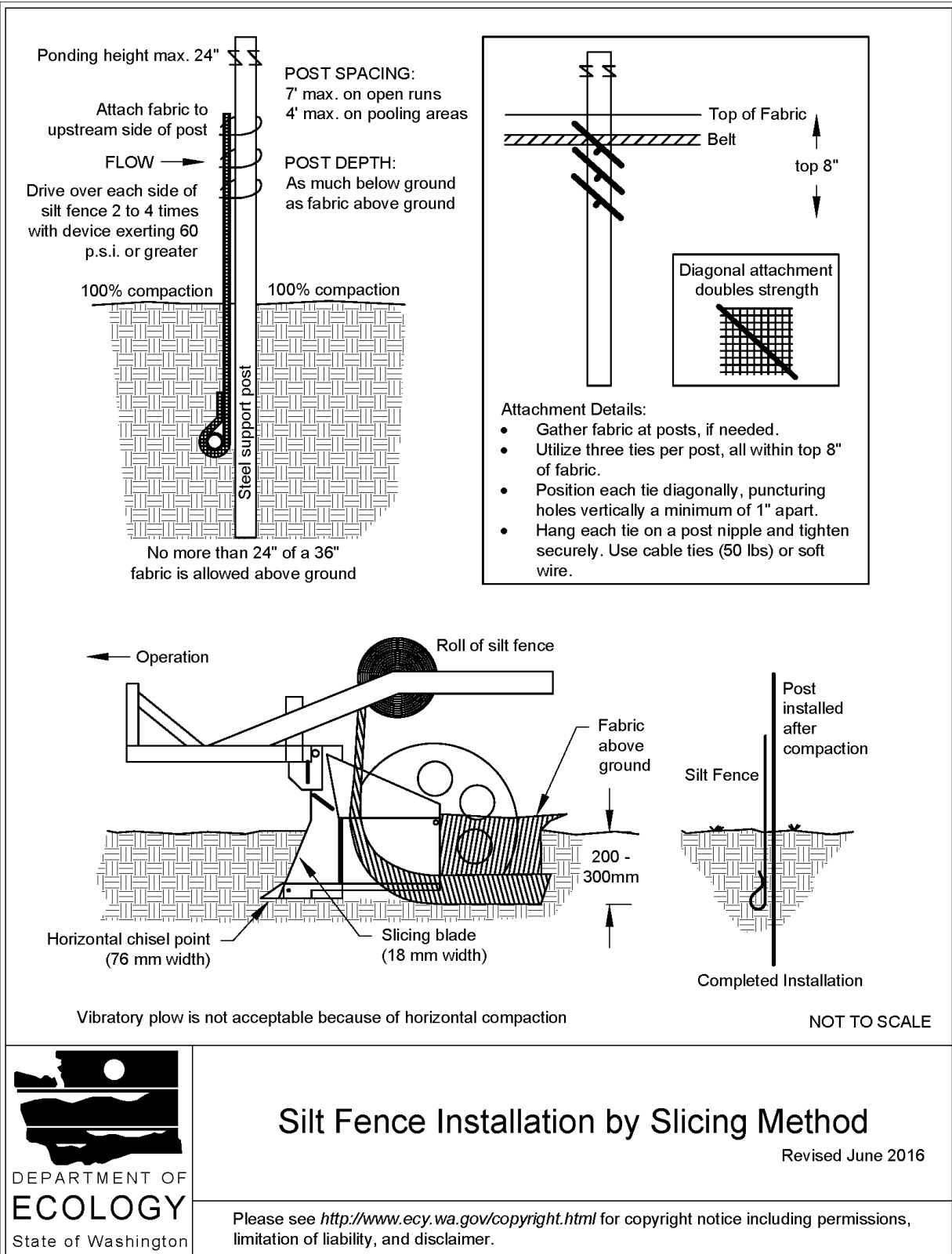

## ***Maintenance Standards***

- Repair any damage immediately.
- Intercept and convey all evident concentrated flows uphill of the silt fence to a sediment trapping BMP.
- Check the uphill side of the silt fence for signs of the fence clogging and acting as a barrier to flow and then causing channelization of flows parallel to the fence. If this occurs, replace the fence and remove the trapped sediment.
- Remove sediment deposits when the deposit reaches approximately one-third the height of the silt fence, or install a second silt fence.
- Replace geotextile fabric that has deteriorated due to ultraviolet breakdown.

## **BMP C235: Wattles**

### ***Purpose***

Wattles are temporary erosion and sediment control barriers consisting of straw, compost, or other material that is wrapped in netting made of natural plant fiber or similar encasing material. They reduce the velocity and can spread the flow of rill and sheet runoff, and can capture and retain sediment.

### ***Conditions of Use***

- Wattles shall consist of cylinders of plant material such as weed-free straw, coir, wood chips, excelsior, or wood fiber or shavings encased within netting made of natural plant fibers unaltered by synthetic materials.
- Use wattles:
  - In disturbed areas that require immediate erosion protection.
  - On exposed soils during the period of short construction delays, or over winter months.
  - On slopes requiring stabilization until permanent vegetation can be established.
- The material used dictates the effectiveness period of the wattle. Generally, wattles are effective for one to two seasons.

- Prevent rilling beneath wattles by entrenching and overlapping wattles to prevent water from passing between them.

## **Design Criteria**

- See [Figure II-3.24: Wattles](#) for typical construction details.
- Wattles are typically 8 to 10 inches in diameter and 25 to 30 feet in length.
- Install wattles perpendicular to the flow direction and parallel to the slope contour.
- Place wattles in shallow trenches, staked along the contour of disturbed or newly constructed slopes. Dig narrow trenches across the slope (on contour) to a depth of 3- to 5-inches on clay soils and soils with gradual slopes. On loose soils, steep slopes, and areas with high rainfall, the trenches should be dug to a depth of 5- to 7- inches, or 1/2 to 2/3 of the thickness of the wattle.
- Start building trenches and installing wattles from the base of the slope and work up. Spread excavated material evenly along the uphill slope and compact it using hand tamping or other methods.
- Construct trenches at intervals of 10- to 25-feet depending on the steepness of the slope, soil type, and rainfall. The steeper the slope the closer together the trenches.
- Install the wattles snugly into the trenches and overlap the ends of adjacent wattles 12 inches behind one another.
- Install stakes at each end of the wattle, and at 4-foot centers along entire length of wattle.
- If required, install pilot holes for the stakes using a straight bar to drive holes through the wattle and into the soil.
- Wooden stakes should be approximately 0.75 x 0.75 x 24 inches min. Willow cuttings or 3/8-inch rebar can also be used for stakes.
- Stakes should be driven through the middle of the wattle, leaving 2 to 3 inches of the stake protruding above the wattle.

**Figure II-3.24: Wattles**

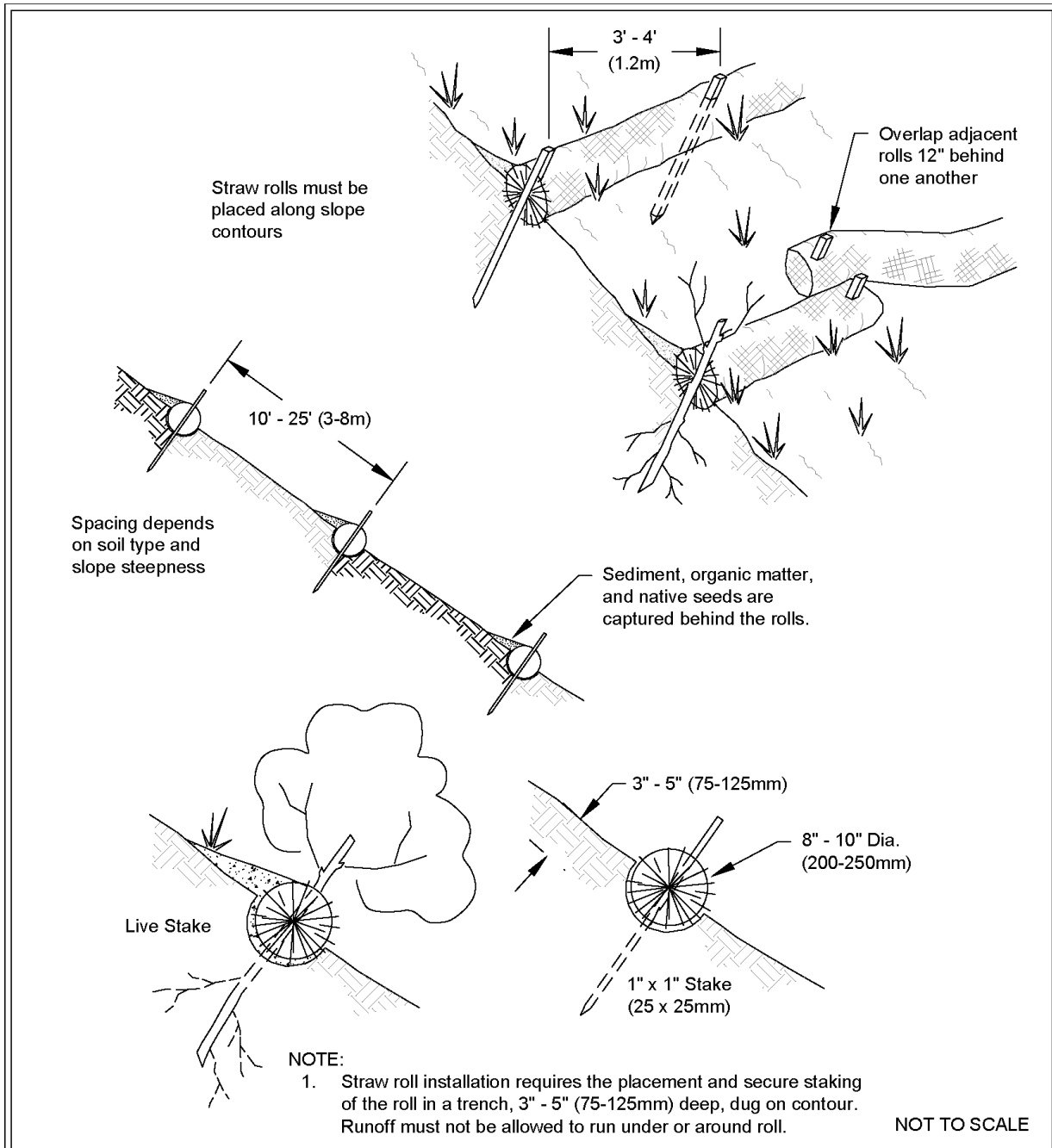

## Wattles

Revised December 2016

Please see <http://www.ecy.wa.gov/copyright.html> for copyright notice including permissions, limitation of liability, and disclaimer.

## ***Maintenance Standards***

- Wattles may require maintenance to ensure they are in contact with soil and thoroughly entrenched, especially after significant rainfall on steep sandy soils.
- Inspect the slope after significant storms and repair any areas where wattles are not tightly abutted or water has scoured beneath the wattles.

## ***Approved as Functionally Equivalent***

Ecology has approved products as able to meet the requirements of this BMP. The products did not pass through the Technology Assessment Protocol – Ecology (TAPE) process. Local jurisdictions may choose not to accept these products, or may require additional testing prior to consideration for local use. Products that Ecology has approved as functionally equivalent are available for review on Ecology’s website at:

<https://ecology.wa.gov/Regulations-Permits/Guidance-technical-assistance/Stormwater-permittee-guidance-resources/Emerging-stormwater-treatment-technologies>

## **BMP C236: Vegetative Filtration**

### ***Purpose***

Vegetative filtration as a BMP is used in conjunction with detention storage in the form of portable tanks or [BMP C241: Sediment Pond \(Temporary\)](#), [BMP C206: Level Spreader](#), and a pumping system with surface intake. Vegetative filtration improves turbidity levels of stormwater discharges by filtering runoff through existing vegetation where undisturbed forest floor duff layer or established lawn with thatch layer are present. Vegetative filtration can also be used to infiltrate dewatering waste from foundations, vaults, and trenches as long as runoff does not occur.

### ***Conditions of Use***

- For every five acres of disturbed soil use one acre of grass field, farm pasture, or wooded area. Reduce or increase this area depending on project size, ground water table height, and other site conditions.
- Wetlands shall not be used for vegetative filtration.
- Do not use this BMP in areas with a high ground water table, or in areas that will have a high seasonal ground water table during the use of this BMP.
- This BMP may be less effective on soils that prevent the infiltration of the water, such as hard till.
- Using other effective source control measures throughout a construction site will prevent the generation of additional highly turbid water and may reduce the time period or area need for this BMP.
- Stop distributing water into the vegetated filtration area if standing water or erosion results.