

BOUNDARY SURVEY NOTES

1. THE INFORMATION FOR THIS SURVEY WAS A 3-SECOND LEICA TCA 1110 TRIANGULAR SURVEY, STATIONING SURVEY.
2. RECORDS USED IN THIS SURVEY MET OR EXCEEDED STANDARDS SET BY WAC 352-130-000. SURVEY WAS COMPLETED BY A FIELD SURVEYOR.
3. ALL MONUMENTS WERE LOCATED DURING THIS SURVEY UNLESS OTHERWISE NOTED.
4. ENCUMBRANCES NOTED AS "M" OR "O" ARE RELATIVE TO THE SUBJECT PROPERTY.
5. ENCUMBRANCES NOTED AS "M" OR "O" ARE RELATIVE TO THE SUBJECT PROPERTY.
6. FENCE DIMENSIONS ARE GENERALLY TO THE CENTERLINE OF THE FENCE UNLESS OTHERWISE NOTED.
7. STRUCTURE LOCATIONS ARE MEASURED TO THE FINISHED FINISH UNLESS OTHERWISE NOTED.
8. ALL DIMENSIONS ARE IN DECIMAL FEET.

TOPOGRAPHIC SURVEY NOTES

1. UTILITIES SHOWN ON THIS SURVEY ARE BASED UPON ABOVE GROUND SURVEYING AND ARE NOT TO BE CONSIDERED AS A BASIS FOR DESIGN. UTILITIES NOT SHOWN AND UTILITIES NOT SHOWN ON THIS SURVEY MAY EXIST ON THE SITE.
2. CONTOURS SHOWN ARE BASED ON A FIELD SURVEY.
3. TREE IDENTIFICATION WAS PERFORMED BY SURVEY FIELD PERSONNEL. TREE IDENTIFICATION WAS PERFORMED BY SURVEY FIELD PERSONNEL. TREE IDENTIFICATION WAS PERFORMED BY SURVEY FIELD PERSONNEL.

PROJECT INFORMATION

PROJECT: PLOG ENGINEERING, PLLC
 ADDRESS: 4457 & 4523 FOREST AVE SE
 MERCEUR ISLAND, WA 98040
 PHONE: (360) 420-7130

PROPERTY OWNER: BRAD & JUDY CHASE
 ADDRESS: 4457 & 4523 FOREST AVE SE
 MERCEUR ISLAND, WA 98040

TAX PARCEL NUMBER: 770010-0185 & 770010-0205

PROJECT ADDRESS: 4457 & 4523 FOREST AVE SE
 MERCEUR ISLAND, WA 98040

PARCEL AREA: 3.94 ACRES (3.94 ACRES ±)
 AS SURVEYED

REFERENCE SURVEYS

81-1-27-2005180002 BLA# 508-001-001
 81-1-27-2005180002 BLA# 508-001-001
 81-1-27-2005180002 BLA# 508-001-001

VERTICAL DATUM & CONTOUR INTERVAL

VERTICAL DATUM - THE VERTICAL DATUM IS THE NORTH AMERICAN DATUM OF 1983 (NAD 83) AND THE ELEVATION IS IN FEET ABOVE MEAN SEA LEVEL.

CONTOUR INTERVAL - THE EXPECTED VERTICAL ACCURACY IS EQUAL TO 1/2 THE CONTOUR INTERVAL OR 1.0' FOR THIS PROJECT.

HORIZONTAL DATUM & BASIS OF BEARINGS

HORIZONTAL DATUM - THE HORIZONTAL DATUM IS THE NORTH AMERICAN DATUM OF 1983 (NAD 83) AND THE BEARINGS ARE BASED ON THE NORTH AMERICAN DATUM OF 1983 (NAD 83) AND THE BEARINGS ARE BASED ON THE NORTH AMERICAN DATUM OF 1983 (NAD 83).

LEGAL DESCRIPTION

THE SOUTH 30 FEET OF LOT 36, ALL OF LOTS 39 AND 40, BEING PART OF SECTION 30, T4N, R10E, S12W, IN KING COUNTY, WASHINGTON, BEING MORE PARTICULARLY DESCRIBED AS FOLLOWS: TOGETHER WITH TOLERANCES OF THE SECOND CLASS ADDING, SITUATE IN THE COUNTY OF KING, STATE OF WASHINGTON.

PARCEL A

LOTS 39 AND 40, BEING PART OF SECTION 30, T4N, R10E, S12W, IN KING COUNTY, WASHINGTON, BEING MORE PARTICULARLY DESCRIBED AS FOLLOWS: TOGETHER WITH TOLERANCES OF THE SECOND CLASS ADDING, SITUATE IN THE COUNTY OF KING, STATE OF WASHINGTON.

PARCEL B

THE SOUTH 30 FEET OF LOT 36, ALL OF LOTS 39 AND 40, BEING PART OF SECTION 30, T4N, R10E, S12W, IN KING COUNTY, WASHINGTON, BEING MORE PARTICULARLY DESCRIBED AS FOLLOWS: TOGETHER WITH TOLERANCES OF THE SECOND CLASS ADDING, SITUATE IN THE COUNTY OF KING, STATE OF WASHINGTON.

- SYMBOL LEGEND**
- MONUMENT AS NOTED
 - SECTION CORNER
 - QUARTER SECTION CORNER
 - FOUND-MONUMENTS-AND-SET
 - SET REBAR AND CAP LS 31976
 - FOUND SURFACE WATER/DRAIN
 - SET SURFACE WATER/DRAIN LS 31976
 - SEWER MAINTENANCE HOLE
 - SEPTIC MAINTENANCE HOLE
 - SEWER CLEAN OUT
 - SEWER LINE
 - STORM DRAIN MAINTENANCE HOLE
 - STORM DRAIN (TYPE 2)
 - STORM DRAIN (TYPE 1)
 - STORM DRAIN CLEAN OUT
 - ROUND YARD DRAIN
 - SQUARE YARD DRAIN
 - STORM DRAIN LINE
 - WATER MAINTENANCE HOLE
 - WATER VALVE
 - WATER METER
 - FIRE HOSE
 - BEAM OFF VALVE
 - IRRIGATION VALVE/FUNCTION
 - WATER LINE
 - GAS VALVE
 - CAN GAS METER
 - GAS LINE
 - CABLE REBAR
 - WIRE CABLE BOX
 - CABLE MAINTENANCE HOLE
 - FIBER OPTIC MAINTENANCE HOLE
 - TELEPHONE MAINTENANCE HOLE
 - TRAYED SIGNAL MAINTENANCE HOLE
 - PAD MOUNTED TRANSFORMER
 - HAND HOLE
 - A/C COMPRESSOR
 - WIND LOOP
 - POWER POLE
 - DUY WIRE
 - STREET LIGHT
 - OVERHEAD UTILITIES (GENERAL/NOTED)
 - UNDERGROUND ELECTRICAL
 - UNDERGROUND TELEPHONE
 - UNDERGROUND UTILITIES (GENERAL/NOTED)
 - UNDERGROUND ELECTRICAL
 - UNDERGROUND CABLE
 - UNDERGROUND TELEPHONE
 - UNDERGROUND FIBER OPTIC
 - BOLLARD
 - WALKER
 - SIGN
 - WINDLAMP FLAG
 - SHAG
 - DECIDUOUS MULTI-TRUNK
 - CONIFER MULTI-TRUNK
 - CONIFER
- ABBREVIATION LEGEND**
- MON = MONUMENT
 - SO = SODAS
 - BLA = BOUNDARY LINE ADJUSTMENT
 - WATER = WATER AS SHOWN HEREIN (D)
 - SEWER = SEWER AS SHOWN HEREIN (D)
 - STORM = STORM DRAIN AS SHOWN HEREIN (D)
 - IRRI = IRRIGATION AS SHOWN HEREIN (D)
 - WATER = WATER AS SHOWN HEREIN (D)
 - WALKER = WALKER
 - SIGN = SIGN
 - WINDLAMP = WINDLAMP FLAG
 - SHAG = SHAG
 - DM = DECIDUOUS MULTI-TRUNK
 - CM = CONIFER MULTI-TRUNK
 - CONIFER = CONIFER

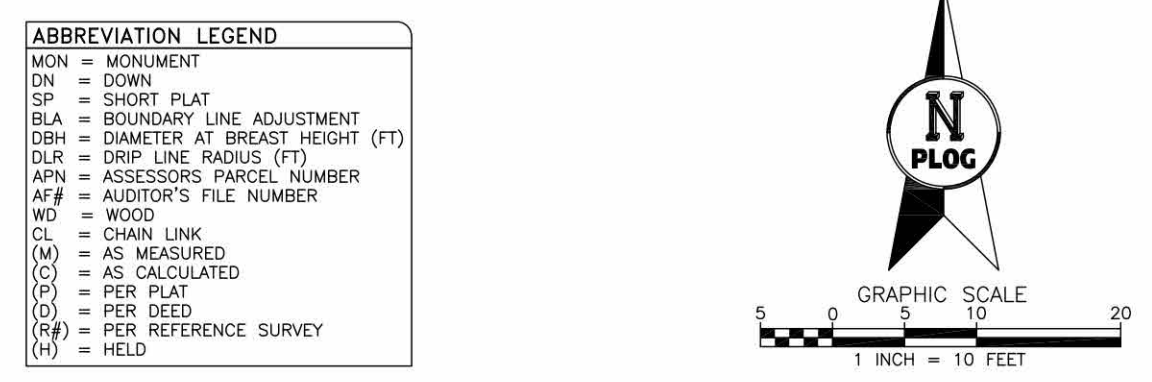

POST-BLA LOT COVERAGE ANALYSIS

South Parcel		North Parcel	
Asphalt	8,780	Asphalt	4,127
Under Roof	2,963	Under Roof	5,671
Concrete	1,742	Concrete	5,176
Decks	240	Decks	1,034
Gravel	647	Gravel	179
Total	14,372	Total	16,187
New Parcel Area	56611	New Parcel Area	49297
New Coverage	25.39%	New Coverage	32.84%

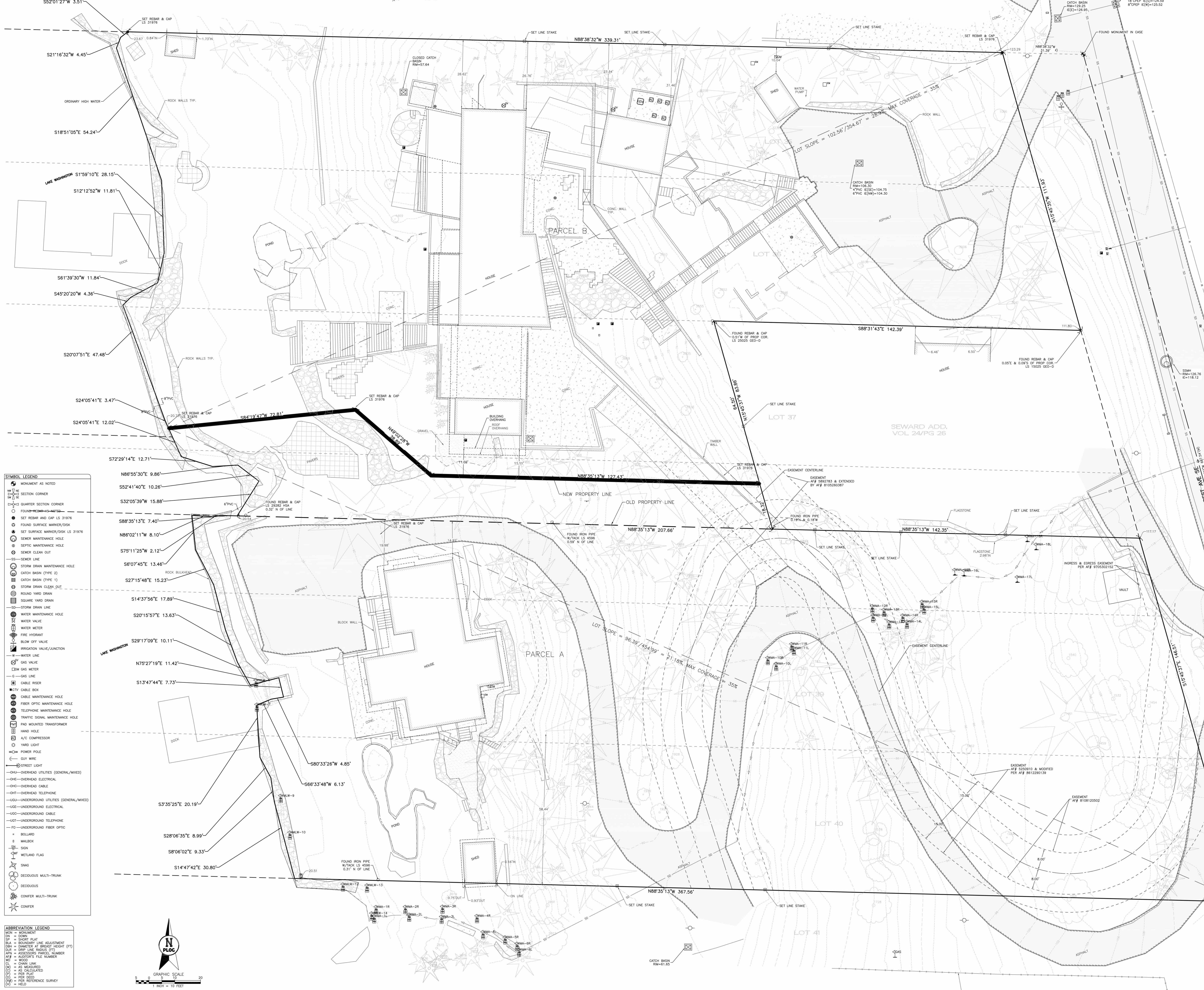

TOPOGRAPHIC & BOUNDARY SURVEY

LEGEND			
	ASPHALT SURFACE		NAIL AS NOTED
	BUILDING		OIL FILL CAP
	CENTERLINE ROW		POWER METER
	CLEANOUT		POWER (OVERHEAD)
	CULVERT PIPE		POWER POLE
	CONCRETE SURFACE		REBAR & CAP (SET)
	RETAINING WALL		ROCKERY
	DECK		SEWER LINE
	DITCH (FLOWLINE)		SEWER MANHOLE
	COLUMN		SIGN (AS NOTED)
	FENCE LINE (WOOD)		STORM MANHOLE
	GAS LINE		STORM DRAIN LINE
	GAS METER		TREE (AS NOTED)
	GUY ANCHOR		WATER LINE
	INLET (TYPE 1)		WATER METER
	MONUMENT IN CASE (FOUND)		WETLAND FLAG
	REBAR/IRON PIPE AS NOTED (FOUND)		

INDEXING INFORMATION	
	W/4E/14 SE 1/4
	SECTION 13
	TOWNSHIP 24N
	RANGE 04E W.M.
	COUNTY KING

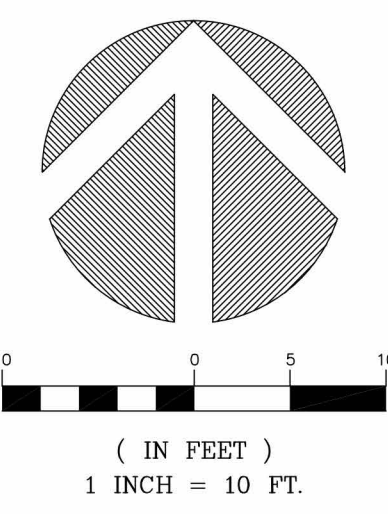

measure success

TOPOGRAPHIC & BOUNDARY SURVEY

PARCEL NO. 7700/00026

HECKENDORN RESIDENCE

4525 FOREST AVE SE
MERCER ISLAND, WA 98040

Terrane
10801 Main Street, Suite 102, Bellevue, WA 98004
phone 425.458.4488 support@terrane.net
www.terrane.net

JOB NUMBER:	211063
DATE:	07/07/21
DRAFTED BY:	IDV/GRD
CHECKED BY:	DRT/JGM
SCALE:	1" = 10'
REVISION HISTORY	
SHEET NUMBER	2 OF 2

FUSED ELEMENTS

4545 FOREST AVENUE SOUTHEAST

MERCER ISLAND, WA 98040

LEGEND / ABBREVIATIONS (EXISTING)

- MONUMENT AS NOTED
- SECTION CORNER
- QUARTER SECTION CORNER
- FOUND REBAR AS NOTED
- SET REBAR AND CAP LS 31976
- FOUND SURFACE MARKER/DISK
- SET SURFACE MARKER/DISK LS 31976
- SEWER MAINTENANCE HOLE
- SEPTIC MAINTENANCE HOLE
- SEWER CLEAN OUT
- SEWER LINE
- STORM DRAIN MAINTENANCE HOLE
- CATCH BASIN (TYPE 2)
- CATCH BASIN (TYPE 1)
- STORM DRAIN CLEAN OUT
- ROUND YARD DRAIN
- SQUARE YARD DRAIN
- STORM DRAIN LINE
- WATER MAINTENANCE HOLE
- WATER VALVE
- WATER METER
- FIRE HYDRANT
- BLOW OFF VALVE
- IRRIGATION VALVE/JUNCTION
- WATER LINE
- GAS VALVE
- GAS METER
- GAS LINE
- CABLE RISER
- CABLE BOX
- CABLE MAINTENANCE HOLE
- FIBER OPTIC MAINTENANCE HOLE
- TELEPHONE MAINTENANCE HOLE
- TRAFFIC SIGNAL MAINTENANCE HOLE
- PAD MOUNTED TRANSFORMER
- HAND HOLE
- A/C COMPRESSOR
- YARD LIGHT
- POWER POLE
- GUY WIRE
- STREET LIGHT
- OVERHEAD UTILITIES (GENERAL/MIXED)
- OVERHEAD ELECTRICAL
- OVERHEAD CABLE
- OVERHEAD TELEPHONE
- UNDERGROUND UTILITIES (GENERAL/MIXED)
- UNDERGROUND ELECTRICAL
- UNDERGROUND CABLE
- UNDERGROUND TELEPHONE
- UNDERGROUND FIBER OPTIC
- BOLLARD
- MAILBOX
- SIGN
- WETLAND FLAG
- SNAG
- DECIDUOUS MULTI-TRUNK
- DECIDUOUS
- CONIFER MULTI-TRUNK
- CONIFER

ABBREVIATION LEGEND

- MON = MONUMENT
- DN = DOWN
- SP = SHORT PLAT
- BLA = BOUNDARY LINE ADJUSTMENT
- DBH = DIAMETER AT BREAST HEIGHT (FT)
- DLR = DRIP LINE RADIUS (FT)
- APN = ASSESSOR'S PARCEL NUMBER
- AF# = AUDITOR'S FILE NUMBER
- WD = WOOD
- CL = CHAIN LINK
- (M) = AS MEASURED
- (C) = AS CALCULATED
- (P) = PER PLAT
- (D) = PER DEED
- (R#) = PER REFERENCE SURVEY
- (H) = HELD

LEGEND (PROPOSED)

- PROPERTY LINE
- EASEMENT CENTERLINE
- LIMITS OF WORK
- SAWCUT
- FILTER FENCE
- DEMOLISH SURFACE FEATURE
- WATTLE
- STORM DRAIN
- PERFORATED STORM DRAIN
- FOOTING DRAIN
- SANITARY SIDE SEWER
- WATER LINE
- ORDINARY HIGH WATER LINE
- ELECTRICAL SERVICE
- MAJOR CONTOUR
- MINOR CONTOUR
- SHORING WALL
- CAST IN PLACE RETAINING WALL
- ROCKERY
- CAP
- SANITARY SEWER BACKFLOW VALVE CHAMBER
- STORM DRAIN CATCH BASIN
- AREA DRAIN
- CLEANOUT
- WATER METER
- RBPA
- CONCRETE PAVING
- ASPHALT PAVING
- ASPHALT GRIND & OVERLAY
- CONCRETE SIDEWALK
- GRAVEL FOOTPATH
- SEE LANDSCAPE

ABBREVIATIONS (PROPOSED)

- ARCH ARCHITECTURE
- BMP BEST MANAGEMENT PRACTICE
- BW BOTTOM OF WALL
- CB CATCH BASIN
- CIP CAST IN PLACE
- CI CITY OF MERCER ISLAND
- CO CLEANOUT
- CSBC CRUSHED SURFACING BASE COURSE
- DTL DETAIL
- DOE DEPARTMENT OF ECOLOGY
- EL ELEVATION
- EX EXISTING
- FD FOOTING DRAIN CLEANOUT
- FL FLOW LINE
- IE INVERT ELEVATION
- MAX MAXIMUM
- MIN MINIMUM
- NTS NOT TO SCALE
- PC POINT OF CURVATURE
- POC POINT OF CONNECTION
- PT POINT OF TANGENCY
- RT RIGHT
- SD STORM DRAIN
- SS SANITARY SIDE SEWER
- STA STATION
- STD STANDARD
- SWMMWM STORM WATER MANAGEMENT MANUAL FOR WESTERN WASHINGTON
- TC TOP OF CURB
- TW TOP OF WALL
- TYP TYPICAL
- WSDOT WASHINGTON STATE DEPARTMENT OF TRANSPORTATION

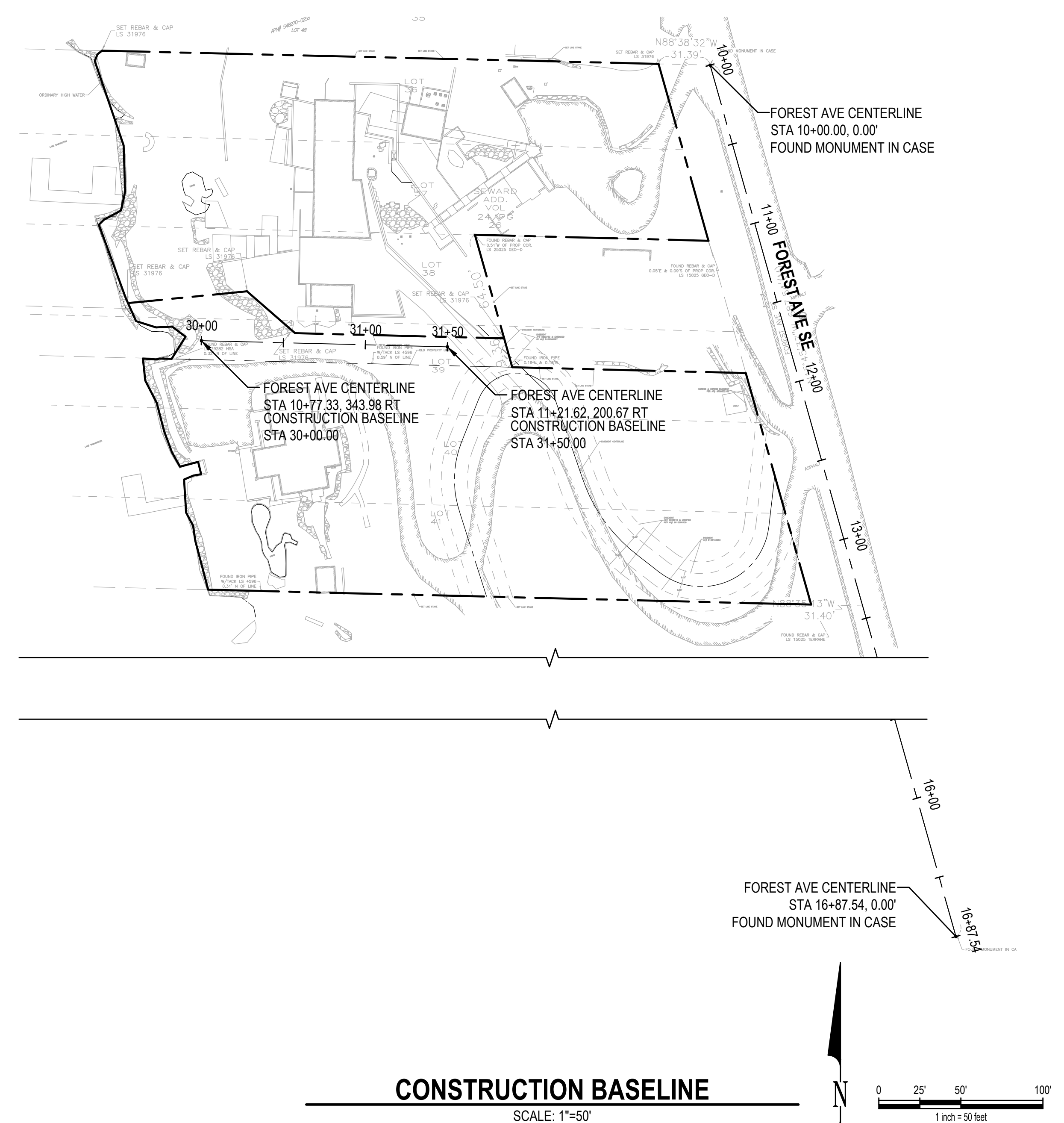

CIVIL SHEET INDEX	
Sheet Number	Sheet Title
C1.00	CIVIL COVER SHEET
C2.00	TESS & DEMOLITION PLAN
C2.50	TREE PROTECTION PLAN
C3.00	GRADING PLAN
C4.00	PAVING & UTILITY PLAN
C4.50	SUBSURFACE DRAINAGE PLAN
C5.00	CIVIL DETAILS
C5.01	CIVIL DETAILS

project:
FUSED ELEMENTS
4525 FOREST AVE SE MERCER ISLAND WA 98040

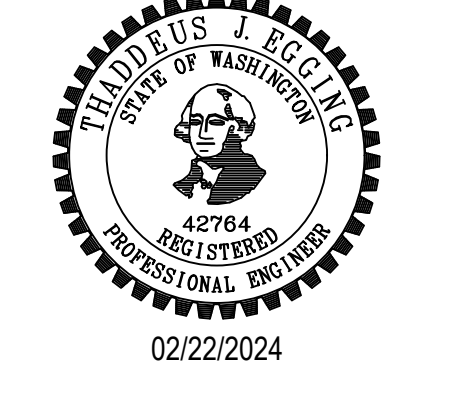
stamp seal:

02/22/2024

project engineer: EAP	
project manager: BCR	
drawn by: EAP/JVL	
checked by: TJE	
job no.: 220707	

revisions:

1 02/23/24	R1 PERMIT
no.: date:	description:

PERMIT SET

09.08.2023

title:

CIVIL COVER SHEET

sheet:

C1.00



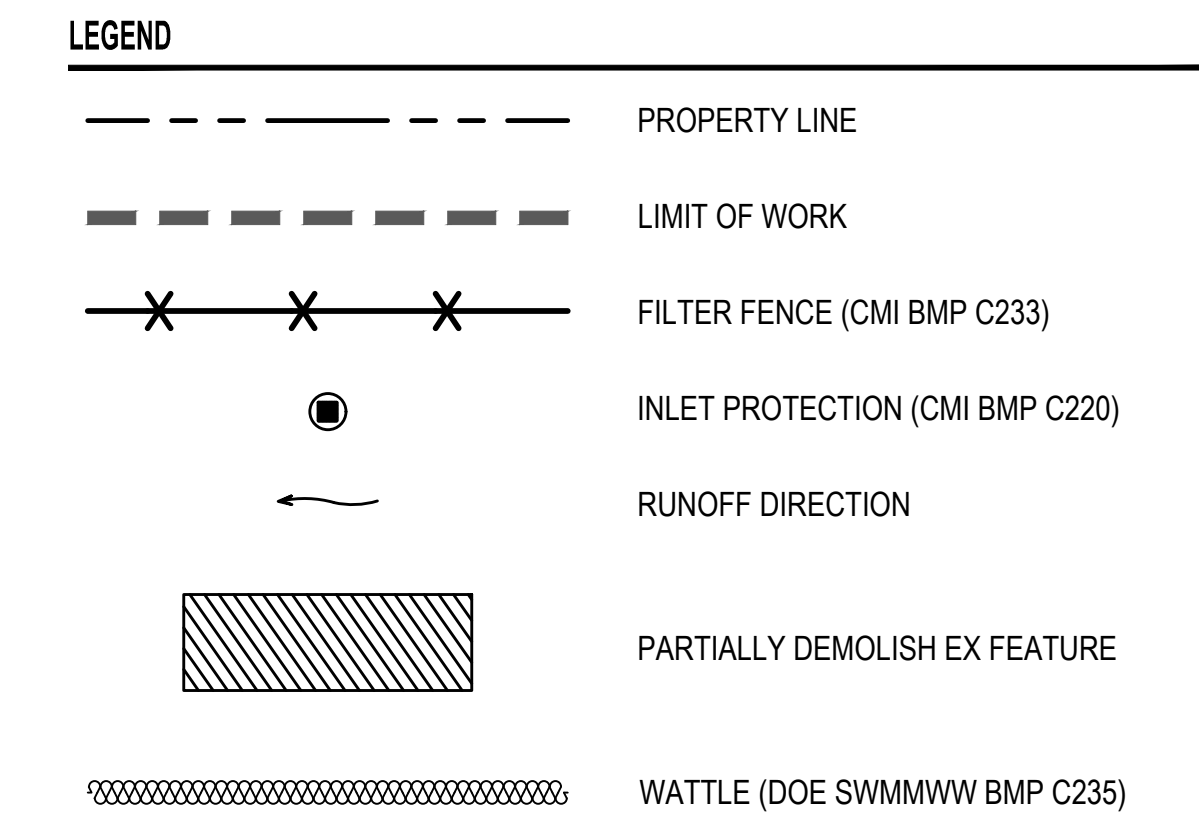
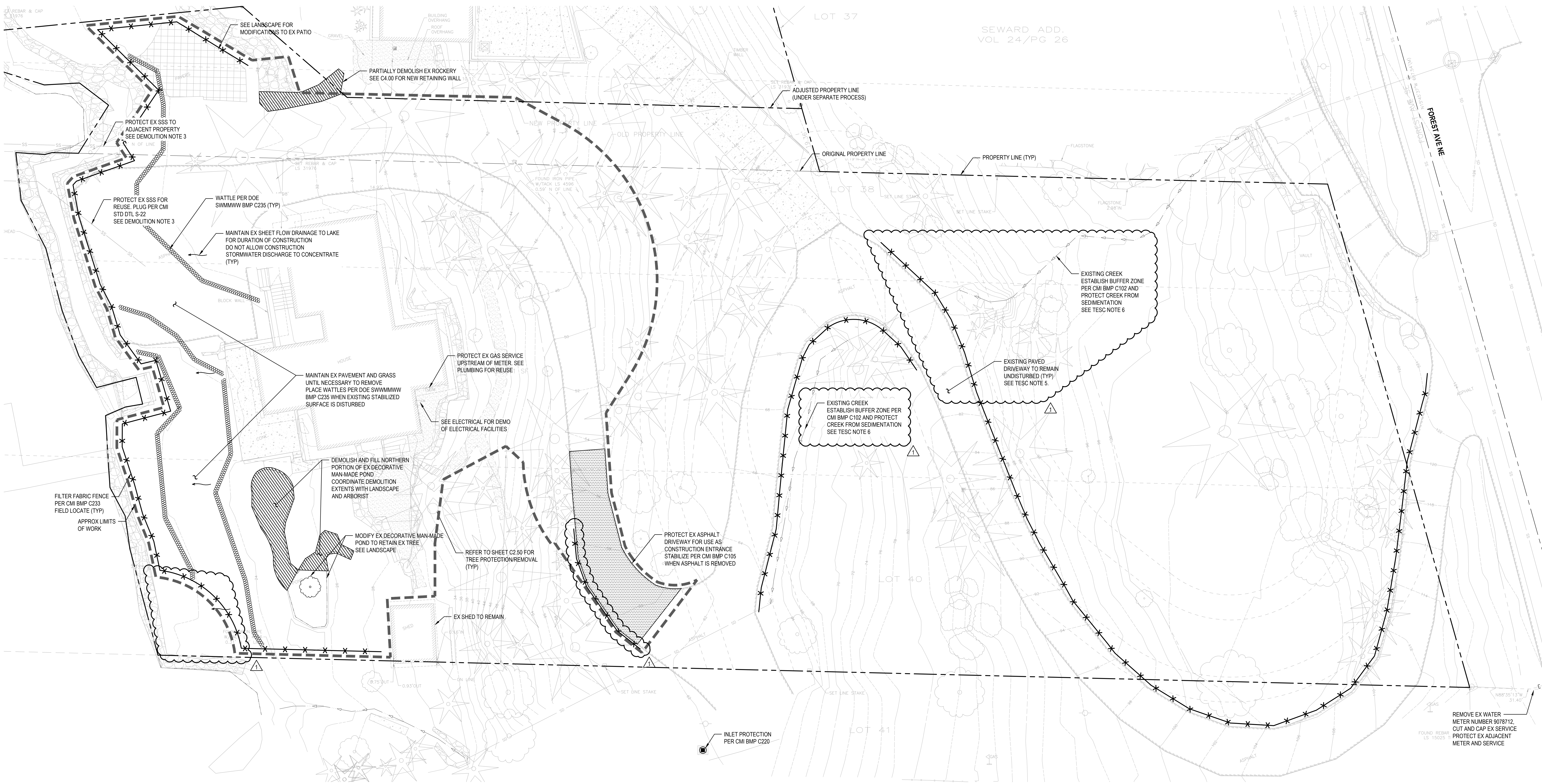

- DEMOLITION NOTES**
- DEMOLISH EXISTING BUILDING, SURFACE IMPROVEMENTS AND UTILITIES WITHIN LIMITS OF WORK UNLESS NOTED OTHERWISE. ALL FEATURES OUTSIDE OF THE LIMIT OF WORK ARE INTENDED TO REMAIN UNDISTURBED UNLESS NOTED OTHERWISE.
 - IF AN UNKNOWN UTILITY SERVICE IS FOUND DURING CONSTRUCTION, NOTIFY THE OWNER AND PROTECT IN PLACE UNLESS DIRECTED OTHERWISE.
 - EX SIDE SEWER LOCATION SHOWN IS APPROXIMATE BASED ON CITY OF MERCER ISLAND GIS RECORDS. CONFIRM LOCATION PRIOR TO STARTING DEMOLITION.
 - DISPOSE OF EXCESS DEMOLITION MATERIAL OFF-SITE IN A SAFE AND LEGAL MANNER.

- TEMPORARY EROSION AND SEDIMENT CONTROL (TESC) NOTES**
- THE TESC FACILITIES SHOWN ON THIS PLAN ARE THE MINIMUM REQUIREMENTS FOR ANTICIPATED SITE CONDITIONS. UPGRADE THE TESC FACILITIES TO ACCOUNT FOR ALL STORM EVENTS.
 - THE TESC FACILITIES SHALL BE INSPECTED AND MAINTAINED AS NECESSARY OR AS DIRECTED BY THE CITY OF MERCER ISLAND INSPECTOR.
 - CATCH BASIN INSERTS SHALL BE PROVIDED FOR ALL STORM DRAIN INLETS AND CATCH BASINS DOWN SLOPE OF DISTURBED AREAS, WITHIN 500 FEET OF THE PROJECT SITE.
 - WATER LEAVING THE SITE DURING CONSTRUCTION, INCLUDING WATER CARRIED BY TRUCK TIRES, SHALL BE CLEAN. THE CONTRACTOR SHALL IMPLEMENT ADDITIONAL SEDIMENTATION CONTROL METHODS AS NEEDED OR AS DIRECTED BY THE CITY OF MERCER ISLAND INSPECTOR.

- EXISTING PAVED DRIVEWAY UPHILL OF THE LIMITS OF DISTURBANCE SHALL REMAIN PAVED AND BE KEPT FREE OF SEDIMENT. SEDIMENT SHALL BE REMOVED FROM ALL TRUCKS AND EQUIPMENT PRIOR TO LEAVING DISTURBED PORTION OF THE PROJECT SITE.
- EXISTING CREEK SHALL BE PROTECTED FROM SEDIMENTATION AND ALL DISTURBANCE BY CONSTRUCTION ACTIVITIES. UPGRADE OR IMPLEMENT ADDITIONAL SEDIMENTATION BMPs SUCH AS CMI BMP C203: WATER BARS, BMP C231: BRUSH BARRIER, BMP C232: GRAVEL FILTER BERM, AND BMP C235: WATTLES IF NECESSARY TO PROTECT CREEK.
- ALL CONSTRUCTION STAGING, STORAGE, AND PARKING SHALL OCCUR ON PRIVATE PROPERTY. CONSTRUCTION STAGING, STORAGE, AND PARKING IN THE FOREST AVENUE RIGHT-OF-WAY OR CMI PARCEL TO THE SOUTH IS NOT ALLOWED.

SEWARD ADD.
VOL 24/Pg 26

project:
FUSED ELEMENTS
4525 FOREST AVE SE MERCER ISLAND WA 98040

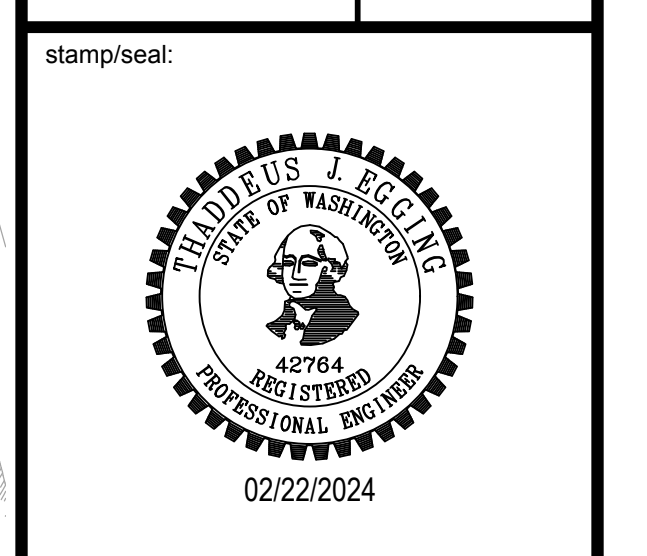

project engineer: EAP
project manager: BCR
drawn by: EAP/JVL
checked by: TJE
job no.: 220707

revisions:

1	02/23/24	R1 PERMIT
no.	date	description

PERMIT SET
09.08.2023

title:
TESC & DEMOLITION PLAN

sheet:
C2.00

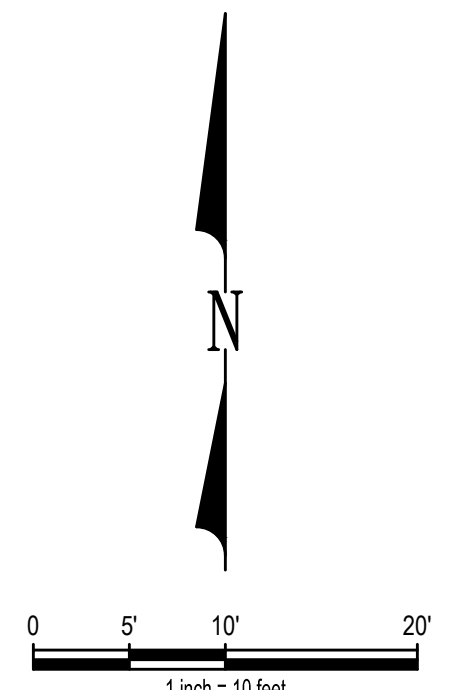

Feb 22, 2024 - 4:35pm
 E:\p
 \\netf.com\Civil\22000001-2209999\2200707 Fused Elements\Design\CADD\Design\Permit\C2_00-TESS-DEMOL.dwg



LEGEND

	PROPERTY LINE
	TREE PROTECTION FENCING 8 CS.00
	APPROXIMATE LIMIT OF WORK
	TREE TO BE REMOVED
	REGULATED TREE
	EXCEPTIONAL TREE WITH DIAMETER LESS THAN 24 INCHES
	EXCEPTIONAL TREE WITH DIAMETER GREATER THAN 24 INCHES

- NOTES**
- * DENOTES EXCEPTIONAL TREE WITH DIAMETER LESS THAN 24 INCHES
 - ** DENOTES EXCEPTIONAL TREE WITH DIAMETER GREATER THAN OR EQUAL TO 24 INCHES.
 - SEE ARBORIST REPORT PREPARED BY TREE SOLUTIONS, INC. AND DATED JUNE 22, 2023, FOR FURTHER TREE INFORMATION INCLUDING TREE SPECIES AND DIAMETER.
 - DIMENSIONS FOR TREE PROTECTION FENCING ARE INTENDED TO BE AT MINIMUM FROM CENTER OF TRUNK TO THE RECOMMENDED LIMIT OF DISTURBANCE (RLOD) DESCRIBED IN THE PROJECT ARBORIST REPORT, EXCEPT WHERE THE RLOD ENDOACHES ON EXISTING PAVED SITE ACCESS.

Z:\2020001-2209999\220707 Fused Elements\Design\CADD\Design\Permits\C2.50-TREE-PROT.dwg
E:\p
Feb 26, 2024 3:56pm

N

0 5 10 20
1"=10' (1"=10')

811 Call 811
two business days before you dig

project
FUSED ELEMENTS
4525 FOREST AVE SE MERCER ISLAND WA 98040

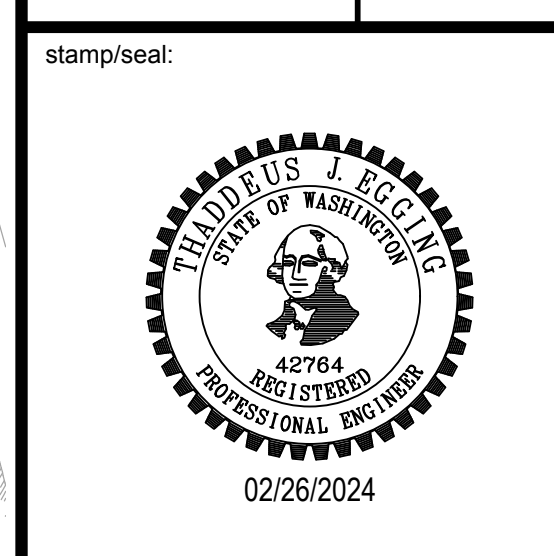

project engineer: EAP
project manager: BCR
drawn by: EAP/JVL
checked by: TJE
job no.: 220707

revisions:

1	02/26/24	R1 PERMIT
no.:	date:	description:

PERMIT SET
09.08.2023

title:
TREE PROTECTION PLAN

sheet:
C2.50

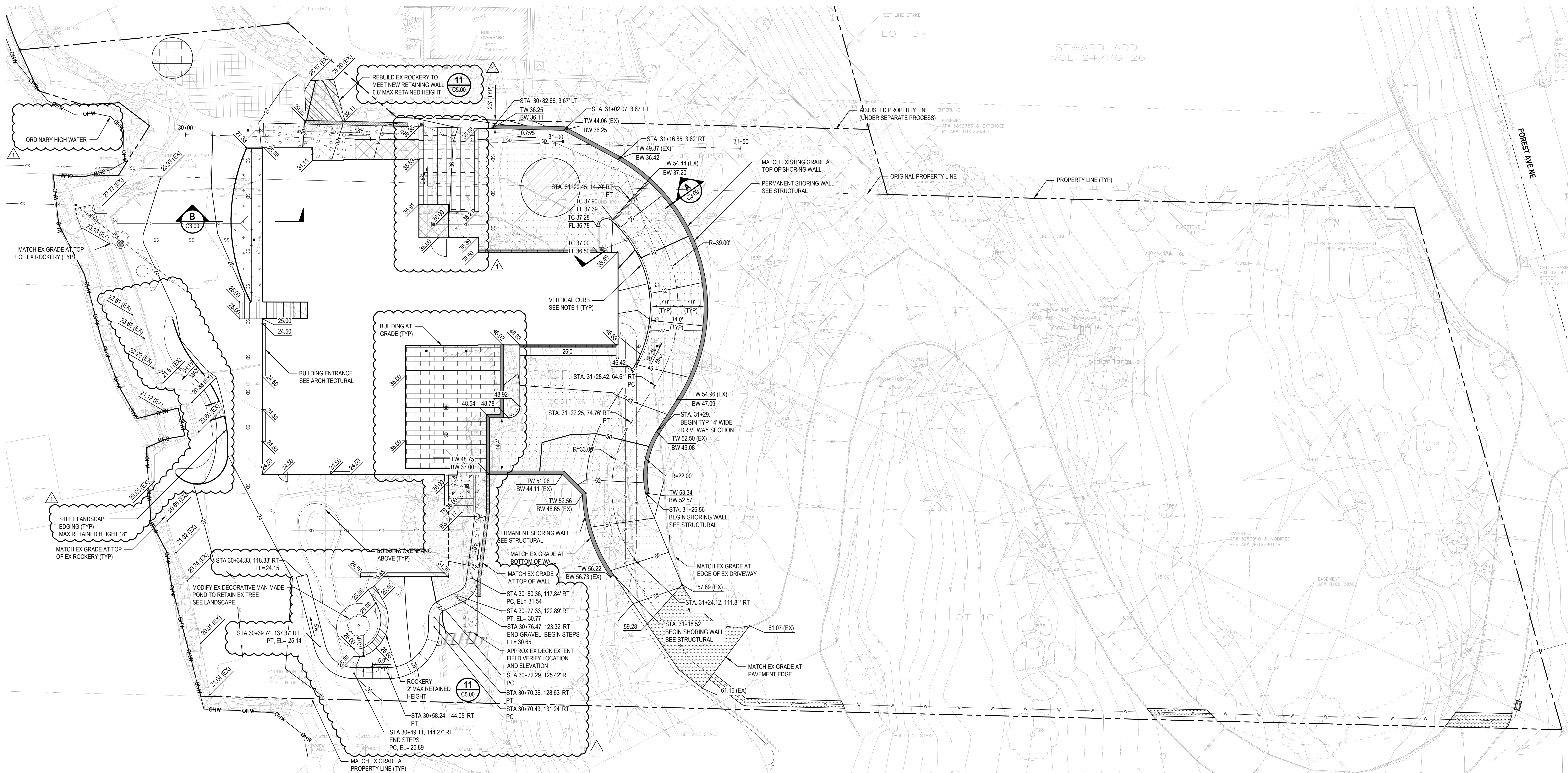

LEGEND	
	PROPERTY LINE
	MAJOR CONTOUR
	MINOR CONTOUR
	GRADE BREAK
	SHORING WALL
	RETAINING WALL
	ROCKERY C3.00
	VERTICAL CURB
	PAVEMENT OVER STRUCTURE OR BUILDING SLAB SEE ARCHITECTURAL
	GRAVEL FOOTPATH SEE LANDSCAPE

- NOTES**
- CURB SPOTS PROVIDED REFER TO ELEVATION AT THE FLOW LINE. REFER TO VERTICAL CURB DETAIL FOR ELEVATION AT TOP OF CURB.
 - REFER TO ARCHITECTURAL FOR ALL GRADING OVER STRUCTURE.

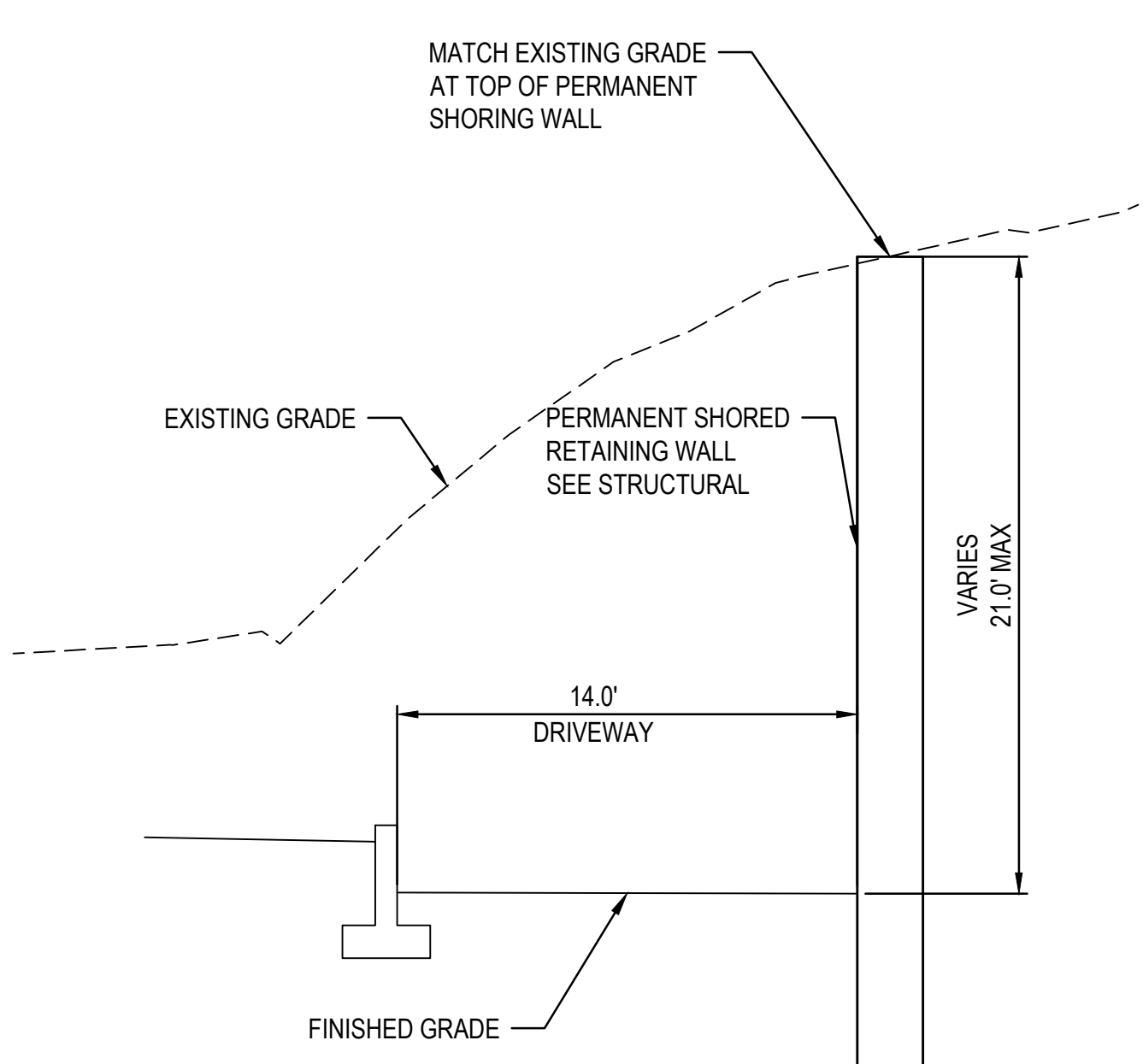

TYPICAL DRIVEWAY WALL SECTION (A)
SCALE 1" = 5'
C3.00

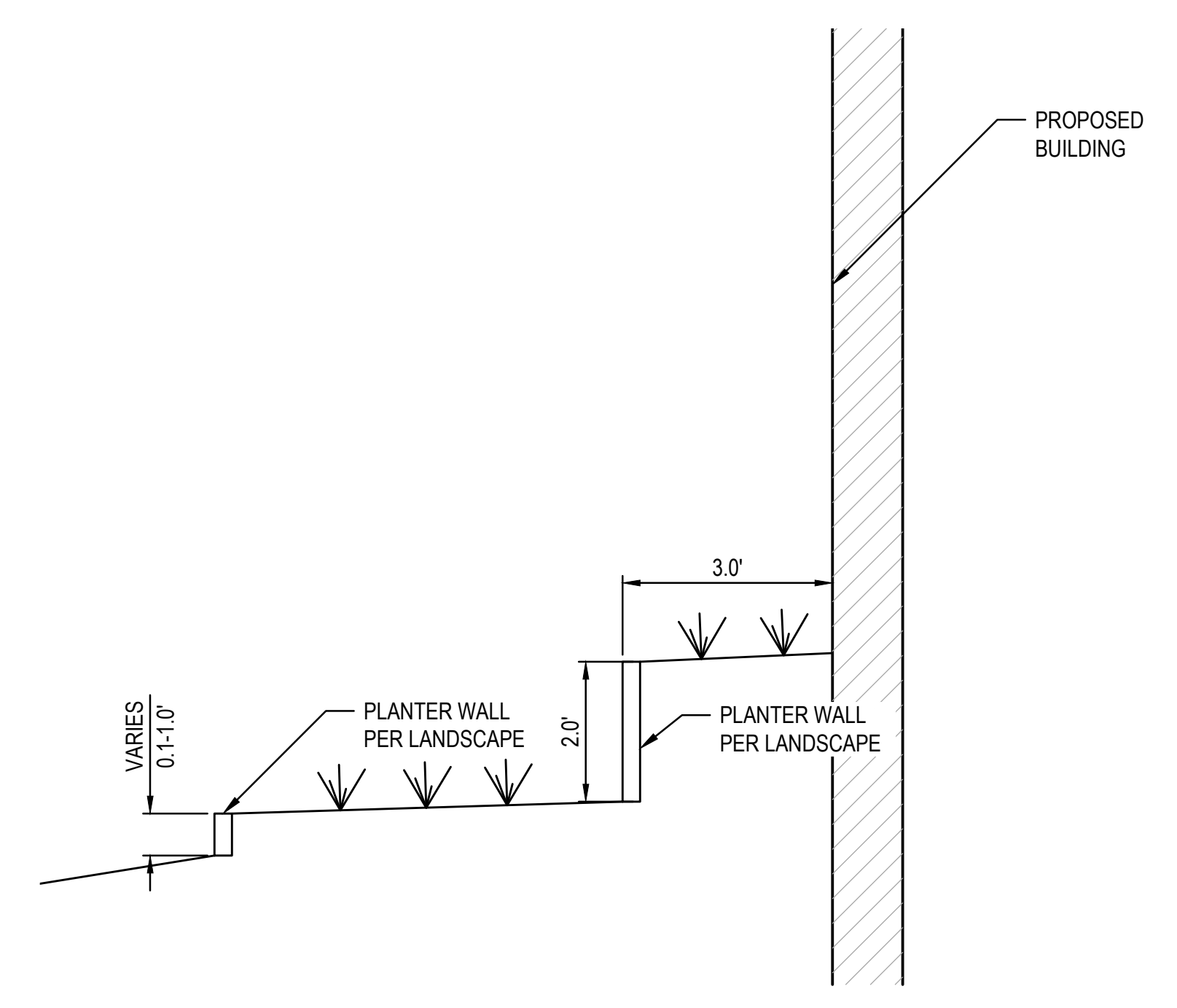

TYPICAL PLANTER SECTION (B)
SCALE 1" = 5'
C3.00

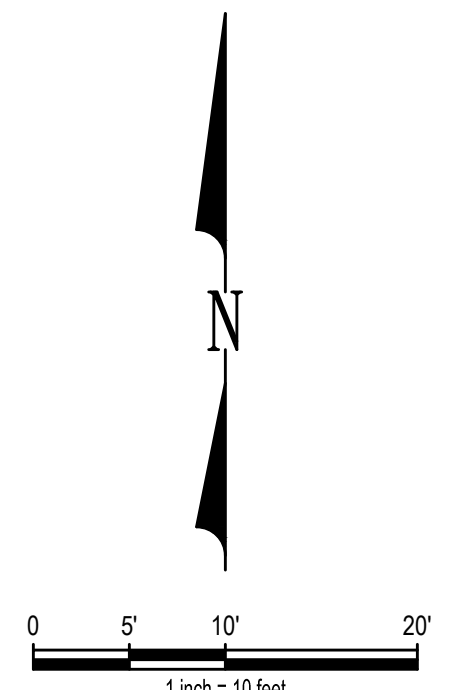

project: **FUSED ELEMENTS**
4525 FOREST AVE SE MERCER ISLAND WA 98040

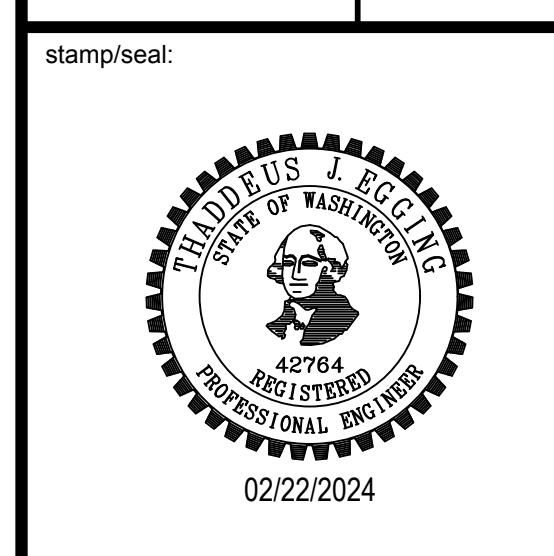

project engineer: EAP
project manager: BCR
drawn by: EAP/JVL
checked by: TJE
job no.: 220707

revisions:

no.	date	description
1	02/23/24	R1 PERMIT

PERMIT SET
09.08.2023

title: **GRADING PLAN**

sheet: **C3.00**



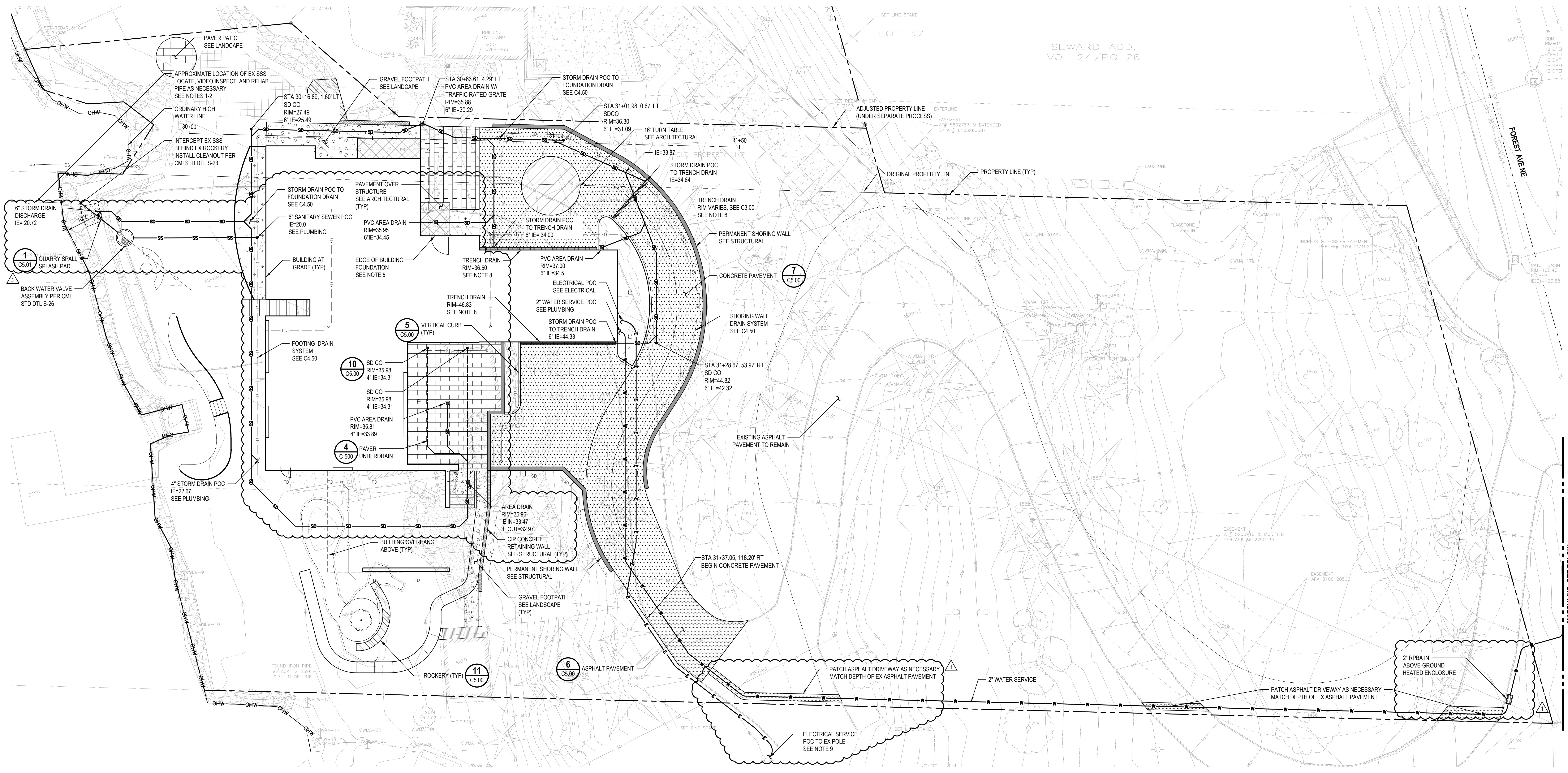

LEGEND	
	PROPERTY LINE
	STORM DRAIN
	PERFORATED STORM DRAIN
	SANITARY SIDE SEWER
	WATER LINE
	ELECTRICAL SERVICE
	SHORING WALL
	RETAINING WALL
	ROCKERY (11) CS.00
	VERTICAL CURB (5) CS.00
	SANITARY SEWER BACKFLOW VALVE CHAMBER
	STORM DRAIN CATCH BASIN
	WATER METER
	PVC AREA DRAIN
	CLEANOUT (3) CS.00
	RPBA (10) CS.00

- NOTES**
- EX SIDE SEWER LOCATION SHOWN IS APPROXIMATE BASED ON CITY OF MERCER ISLAND GIS RECORDS. FIELD VERIFY LOCATION AND DEPTH.
 - SIDE SEWER DISCONNECTION AND RECONNECTION PER CITY OF MERCER ISLAND STANDARD DETAIL S-22.
 - COMMUNICATIONS, AND GAS SERVICES HAVE NOT YET BEEN COORDINATED. IT IS ASSUMED THAT THE SERVICES TO THE EXISTING BUILDING WILL BE REUSED FOR THE NEW DEVELOPMENT.
 - REFER TO LANDSCAPE FOR PLANTING DESIGN AND PEDESTRIAN PAVEMENTS, PAVERS, AND AMENITIES.
 - CONCRETE PAVEMENT TO BE DOWELED INTO BUILDING FOUNDATION AT FLUSH THRESHOLD TO MITIGATE GRADE CHANGE FROM DIFFERENTIAL SETTLEMENT.
 - CONCRETE PANELS SHALL BE JOINTED SO THAT NO PANEL EXCEEDS 14'X14' OR HAS A LENGTH TO WIDTH RATIO OF GREATER THAN 1.25.
 - THE CLOSEST EXISTING HYDRANT IS LOCATED ON THE EAST SIDE OF FOREST AVE SE, APPROXIMATELY 120 FEET NORTH OF THE PROJECT DRIVEWAY ENTRANCE. NO NEW HYDRANTS ARE PROPOSED WITH THIS PROJECT.
 - TRENCH DRAIN SHALL BE ACO KLASSIKRAIN K200 OR AN APPROVED EQUAL, AND SHALL INCLUDE IN-LINE CATCH BASIN WITH SUMP AT THE DOWNSTREAM END. GRATE SHALL BE DUCTILE IRON, LOADING CLASS B, AND BE ADA COMPLIANT AND HEEL PROOF.
 - OBTAIN RIGHT-OF-WAY USE PERMIT FROM THE CITY OF MERCER ISLAND PRIOR TO CONSTRUCTING ANY UTILITIES IN THE RIGHT-OF-WAY.

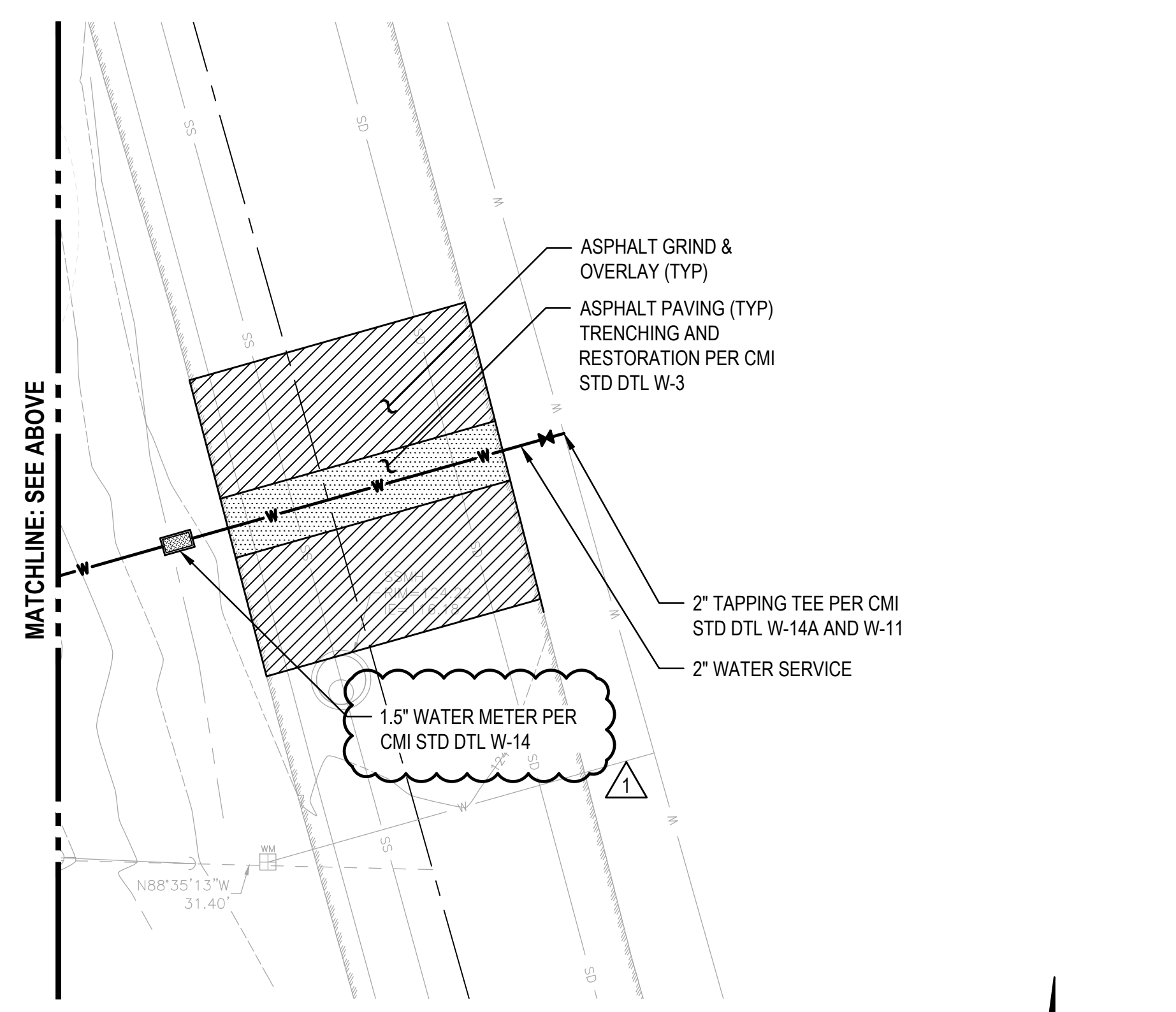

Z:\2020001-2209999\220707 Fused Elements\Design\CADD\Design\Permits\C4.00-U-Title.dwg E:\p Feb 22, 2024 4:42pm

project: **FUSED ELEMENTS**
4525 FOREST AVE SE MERCER ISLAND WA 98040

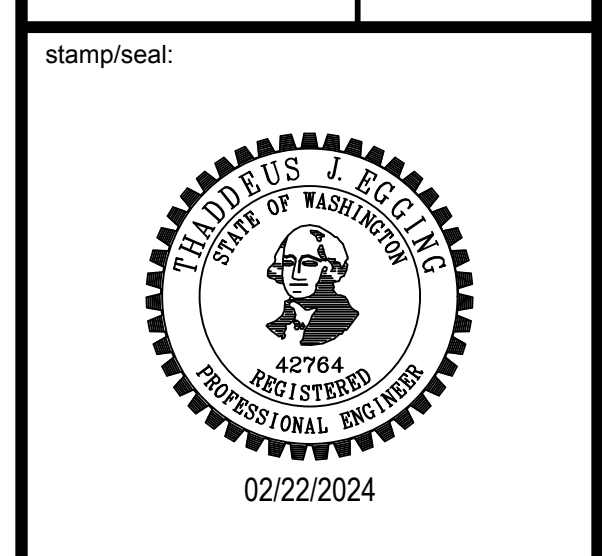

stamp/seal:

project engineer:	EAP
project manager:	BCR
drawn by:	EAP/JVL
checked by:	TJE
job no.:	220707

revisions:

1	02/23/24	R1 PERMIT	
no.:	date:	description:	

PERMIT SET

09.08.2023

title: **PAVING & UTILITY PLAN**

sheet: **C4.00**

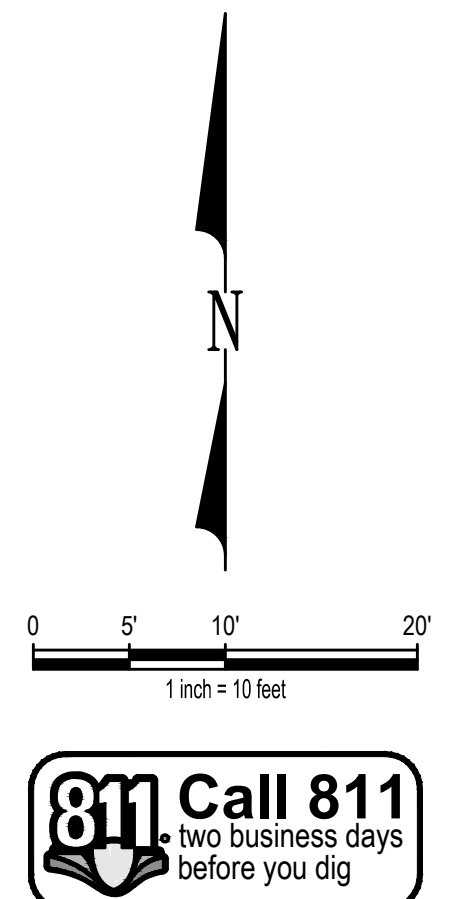

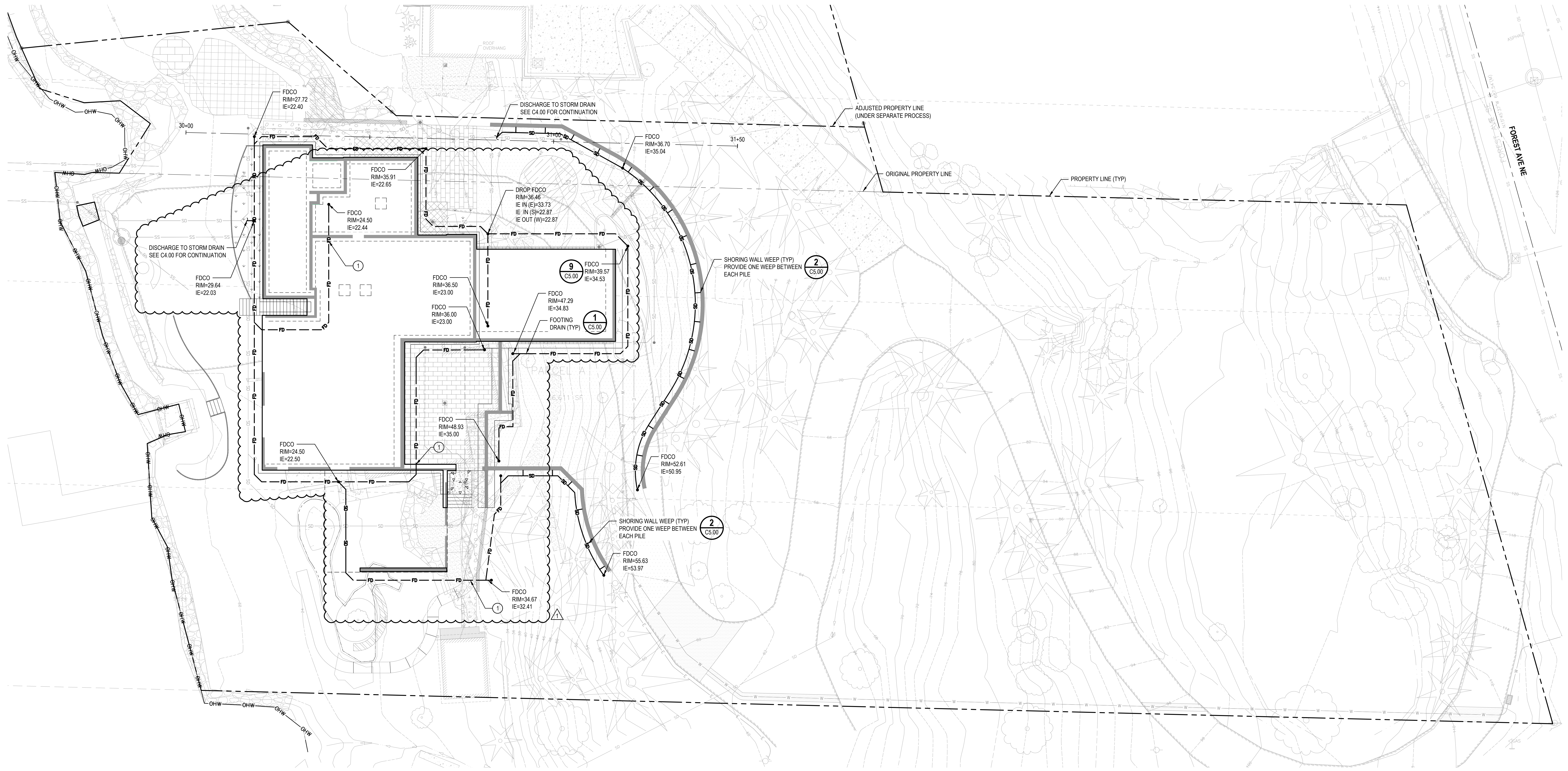

LEGEND

---	PROPERTY LINE
SD	STORM DRAIN
FD	FOOTING DRAIN
•	FOOTING DRAIN CLEANOUT 9 CS.00
■	PVC AREA DRAIN

- NOTES**
- 1 SLEEVE PIPE THROUGH FOUNDATION ELEMENT PER STRUCTURAL.
 - 2 ALL PIPE SHALL BE SLOPED AT 0.5% MINIMUM UNLESS NOTED OTHERWISE.

project:
FUSED ELEMENTS
 4525 FOREST AVE SE MERCER ISLAND WA 98040

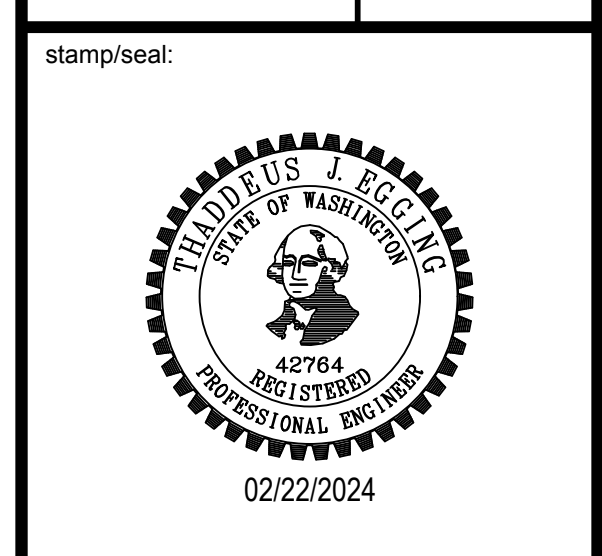

project engineer: EAP
 project manager: BCR
 drawn by: EAP/JVL
 checked by: TJE
 job no.: 220707

revisions:

1	02/23/24	R1 PERMIT
no.:	date:	description:

PERMIT SET
 09.08.2023

title:
SUBSURFACE DRAINAGE PLAN

sheet:
C4.50

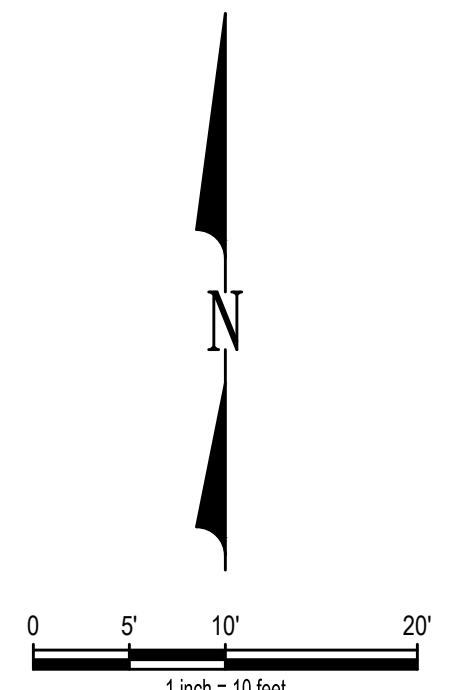

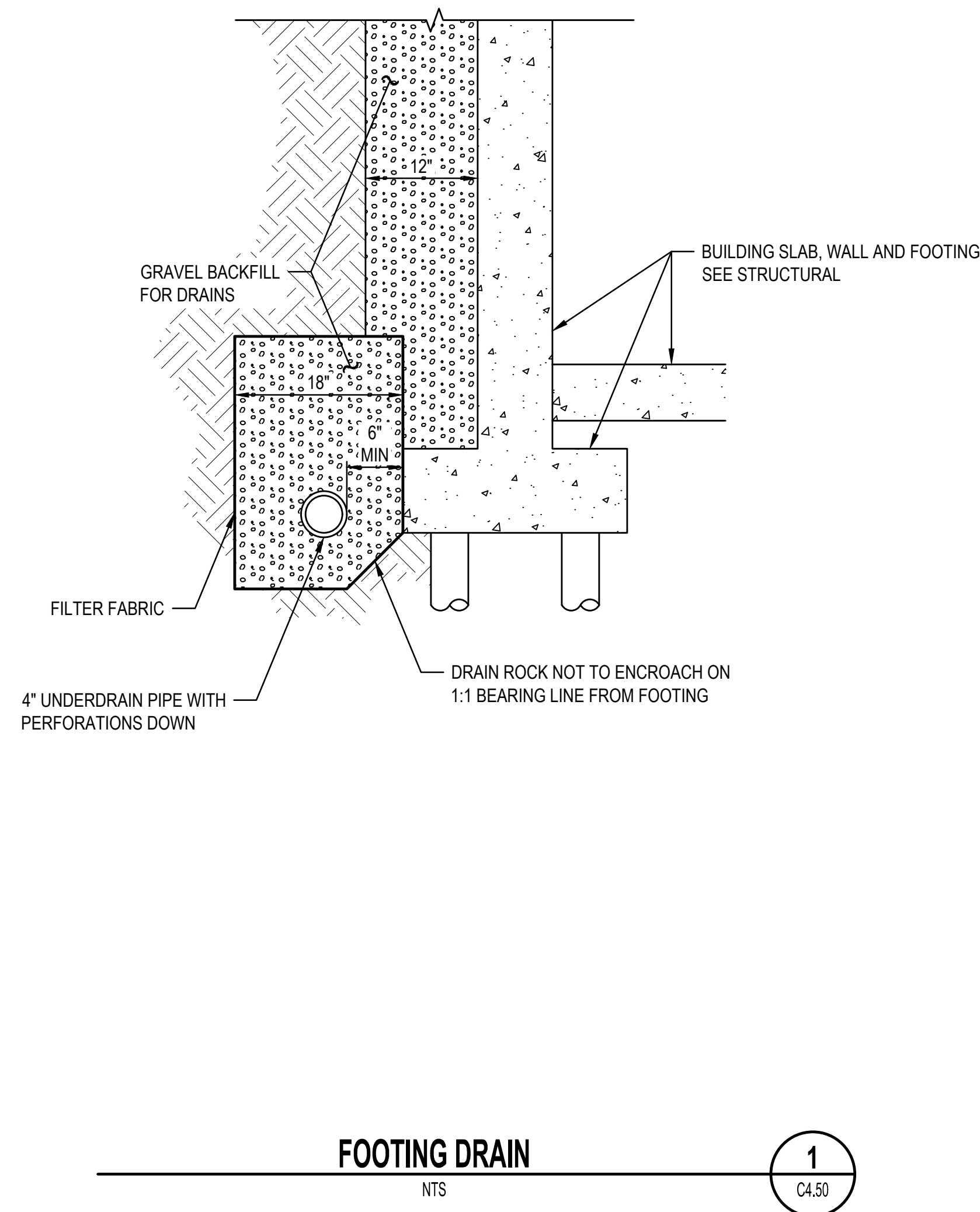

FOOTING DRAIN
NTS

1
C4.50

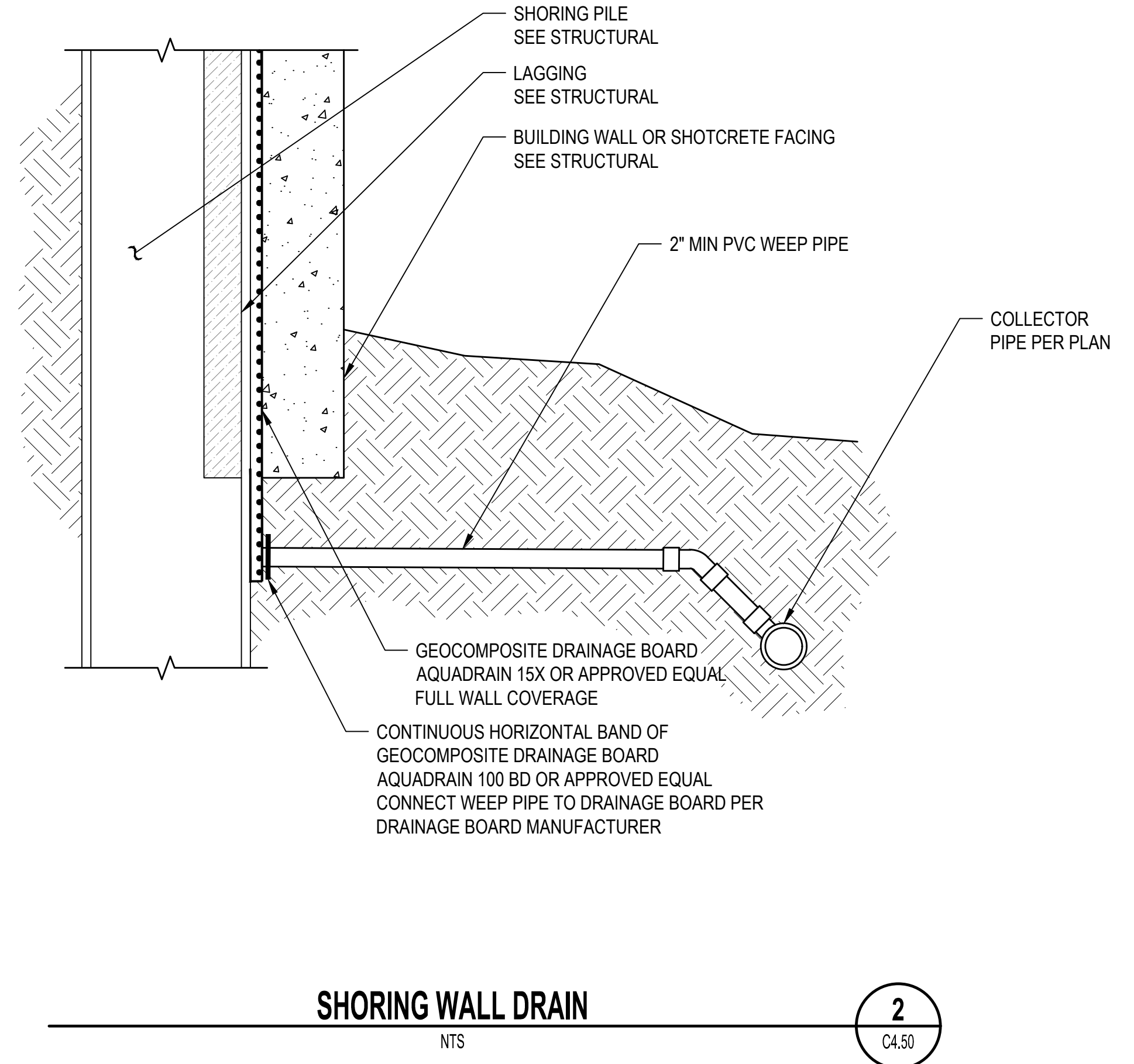

SHORING WALL DRAIN
NTS

2
C4.50

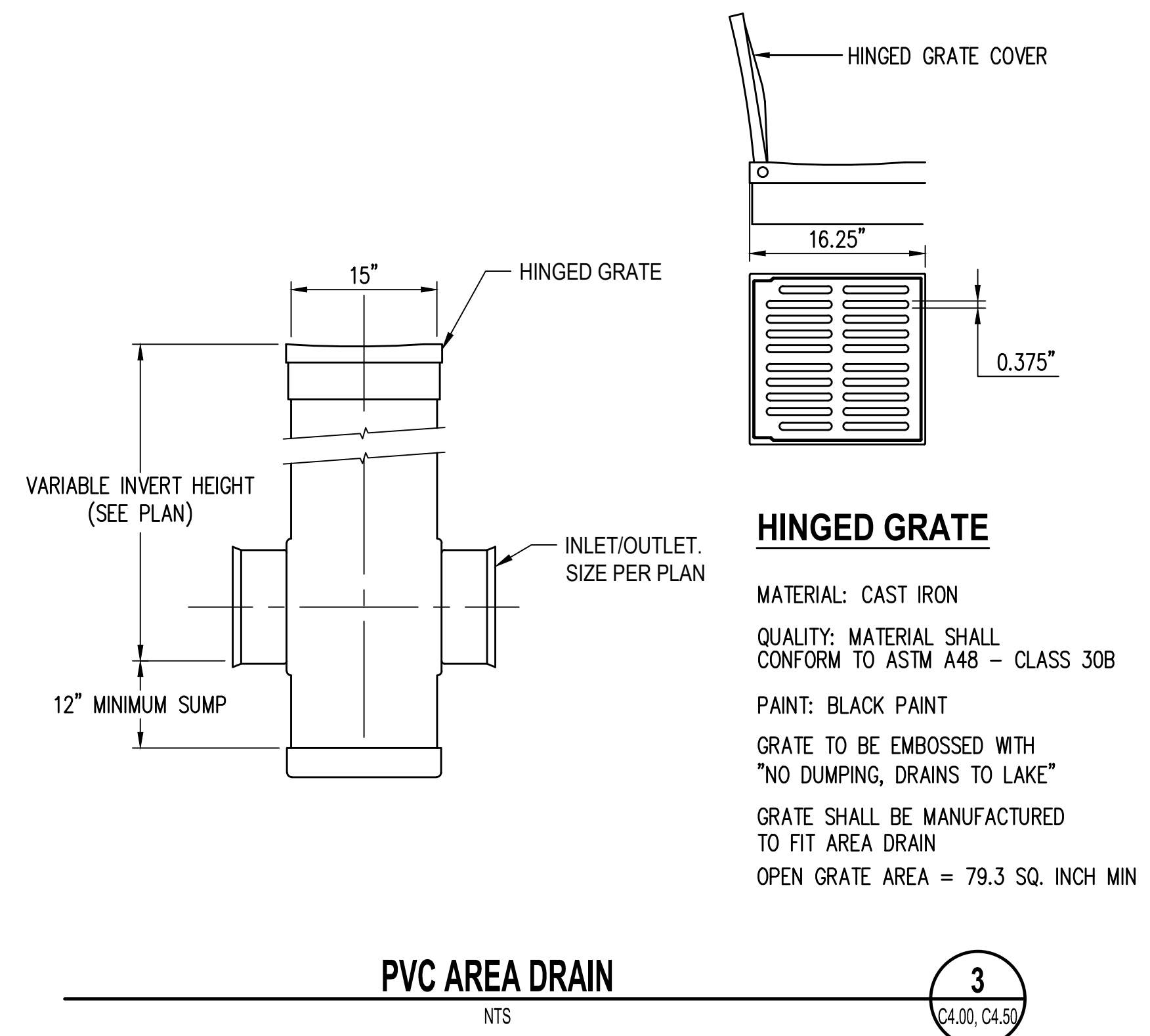

PVC AREA DRAIN
NTS

3
C4.00, C4.50

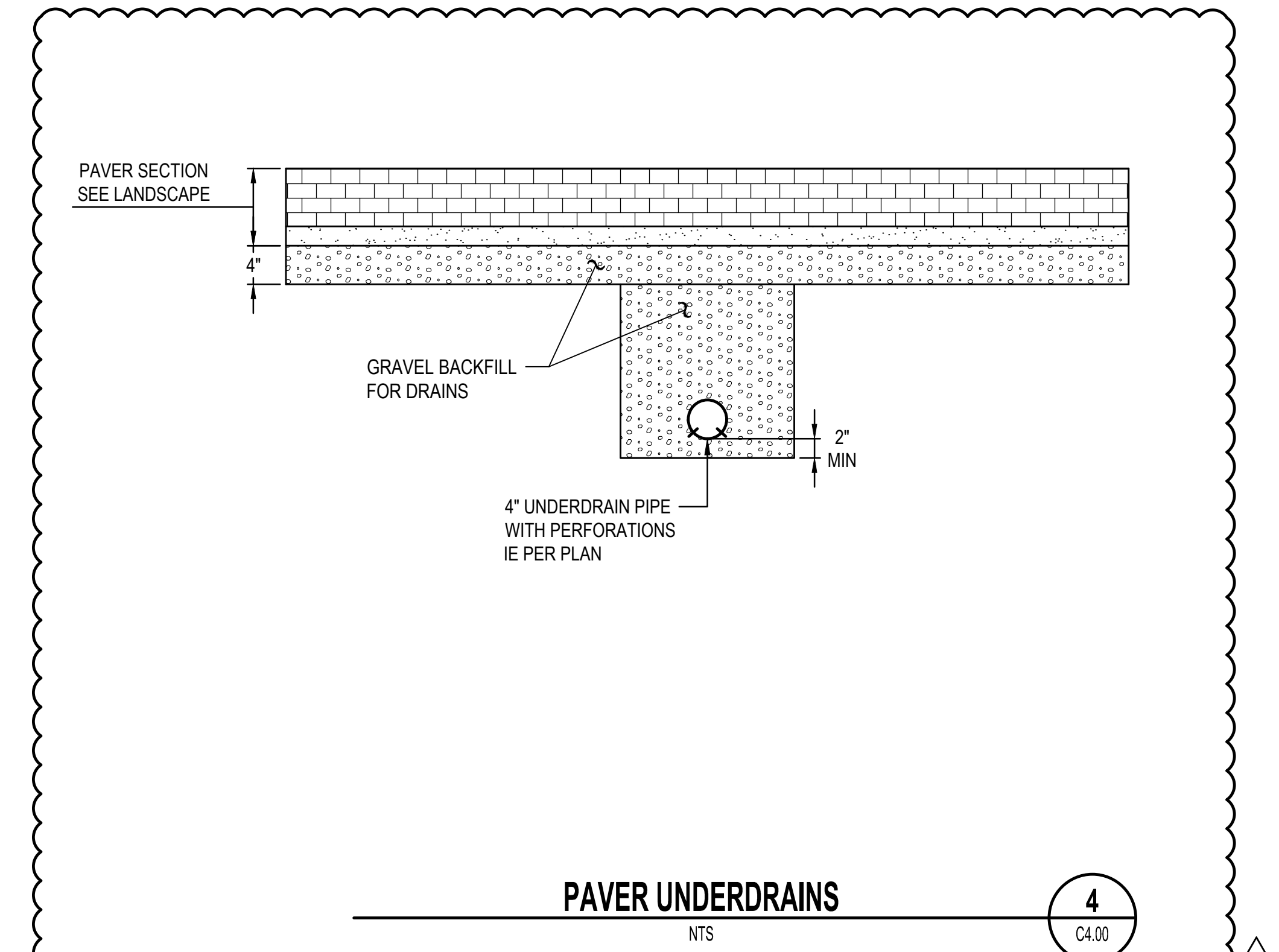

PAVER UNDERDRAINS
NTS

4
C4.00

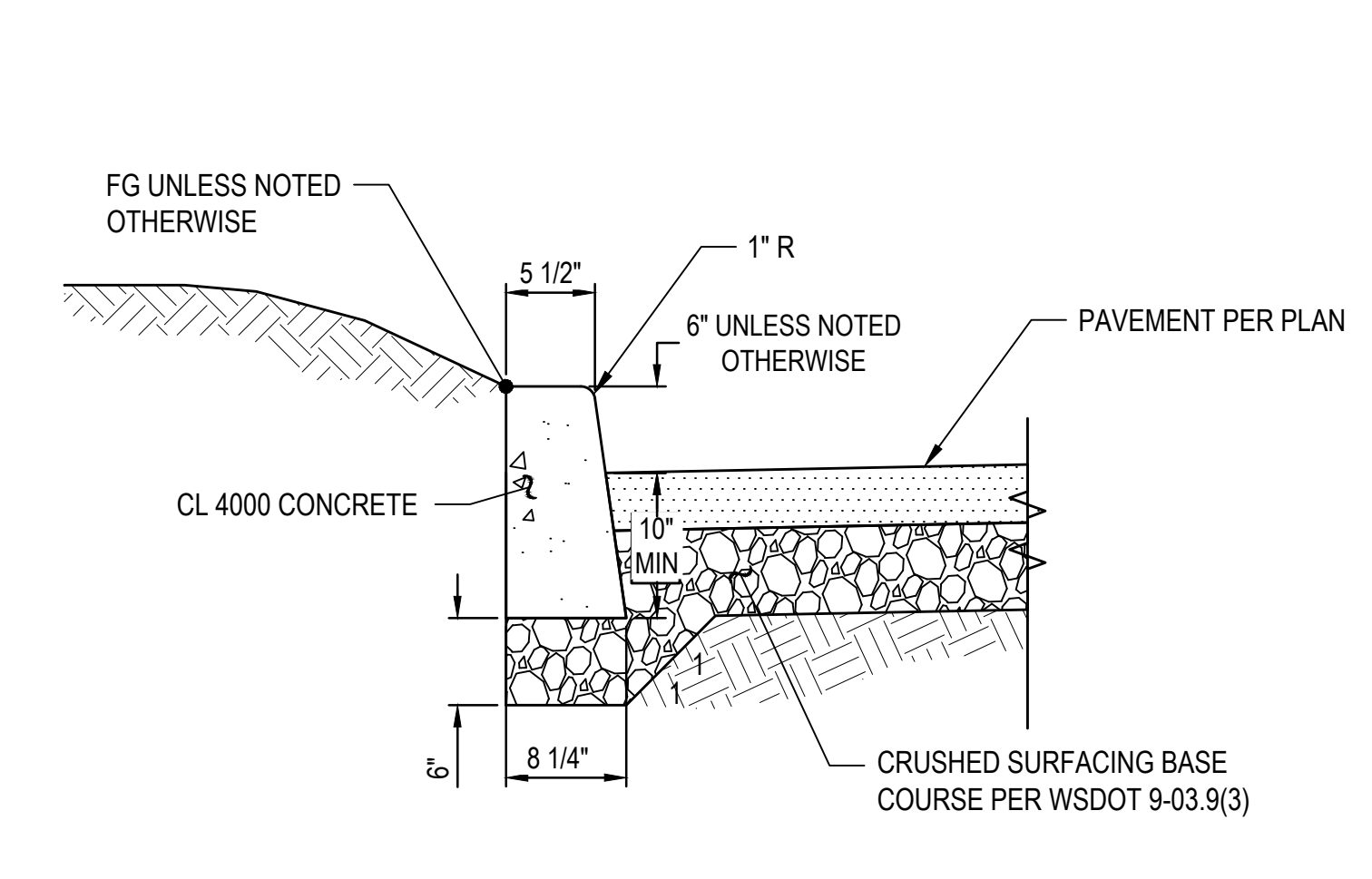

VERTICAL CURB
NTS

5
C4.00

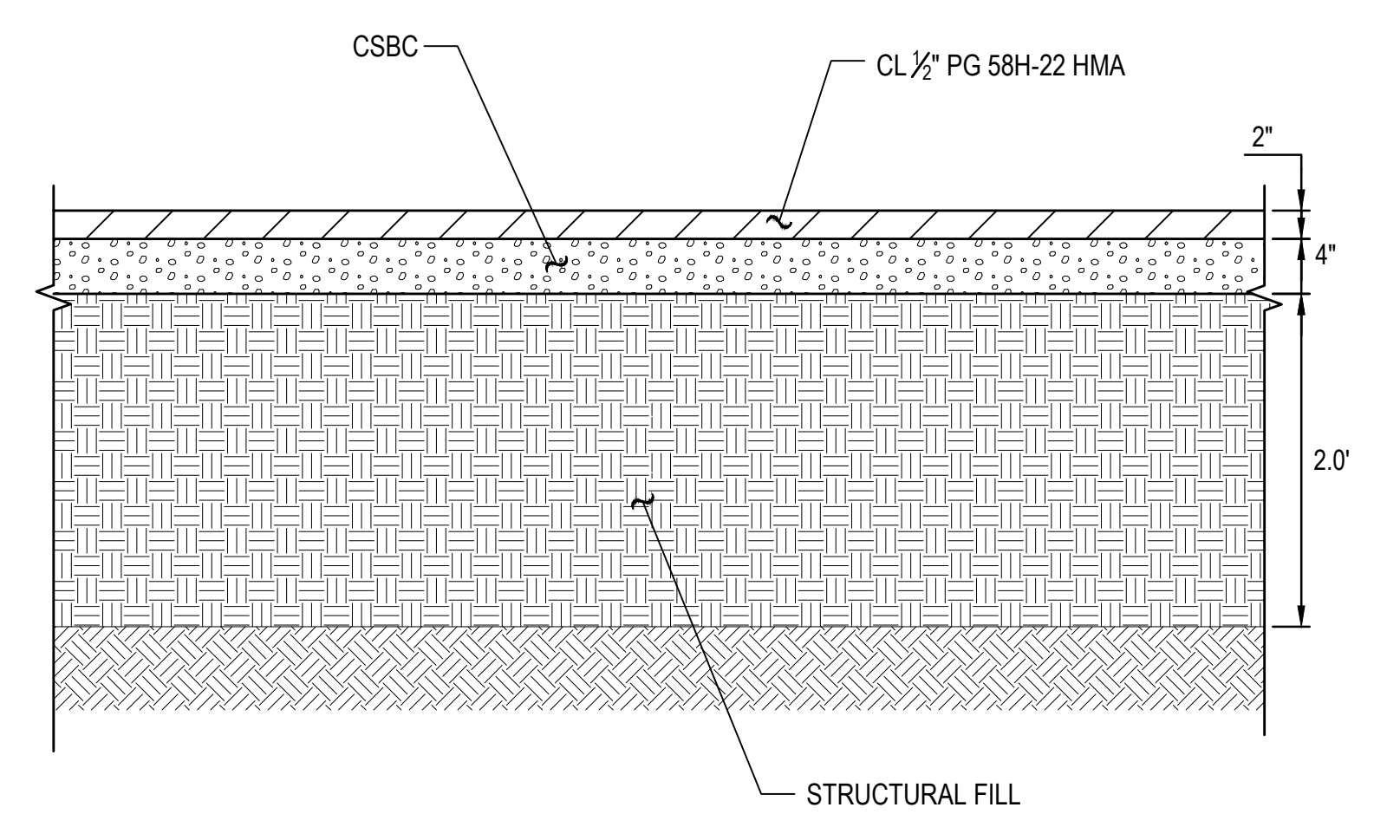

ASPHALT PAVEMENT
NTS

6
C4.00

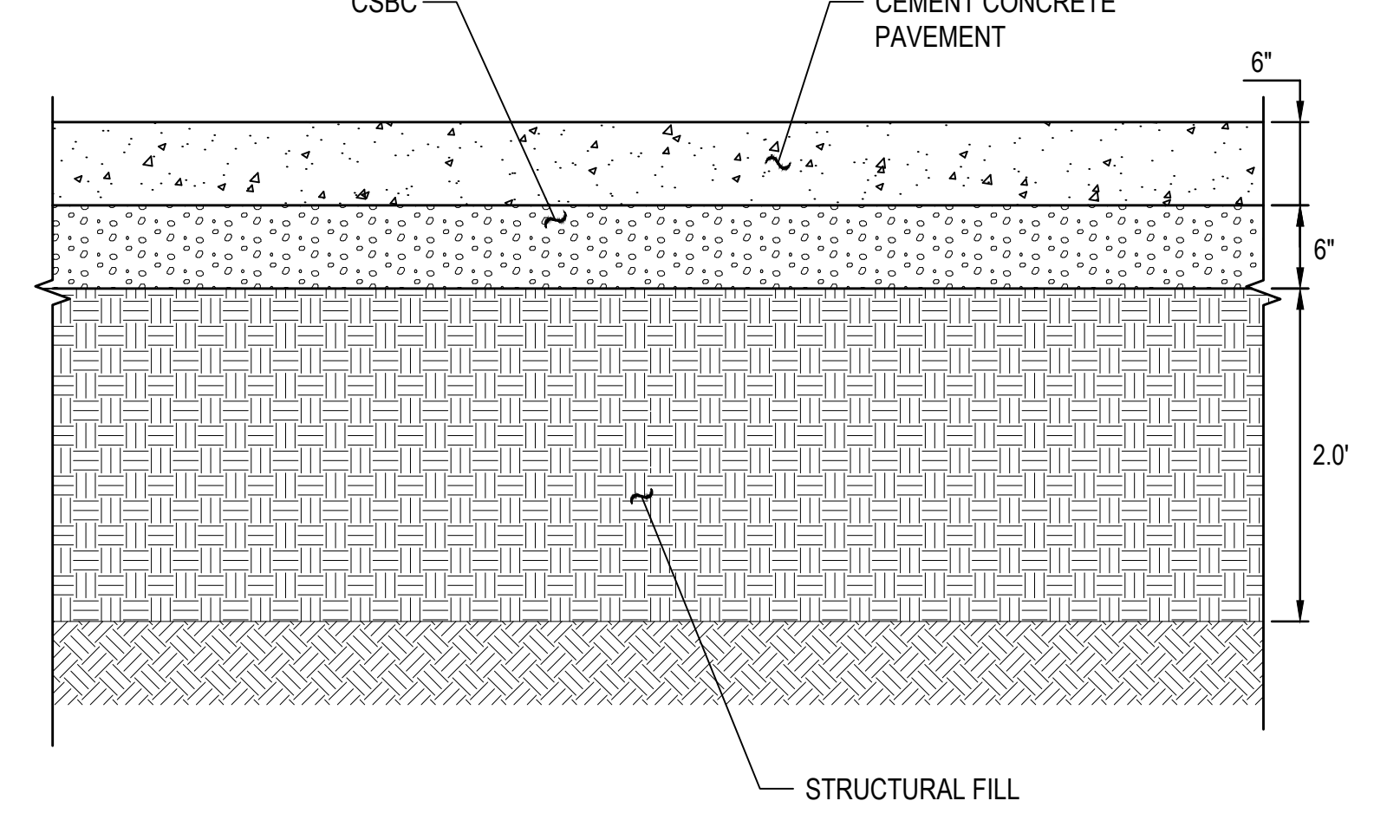

CONCRETE PAVEMENT
NTS

7
C4.00

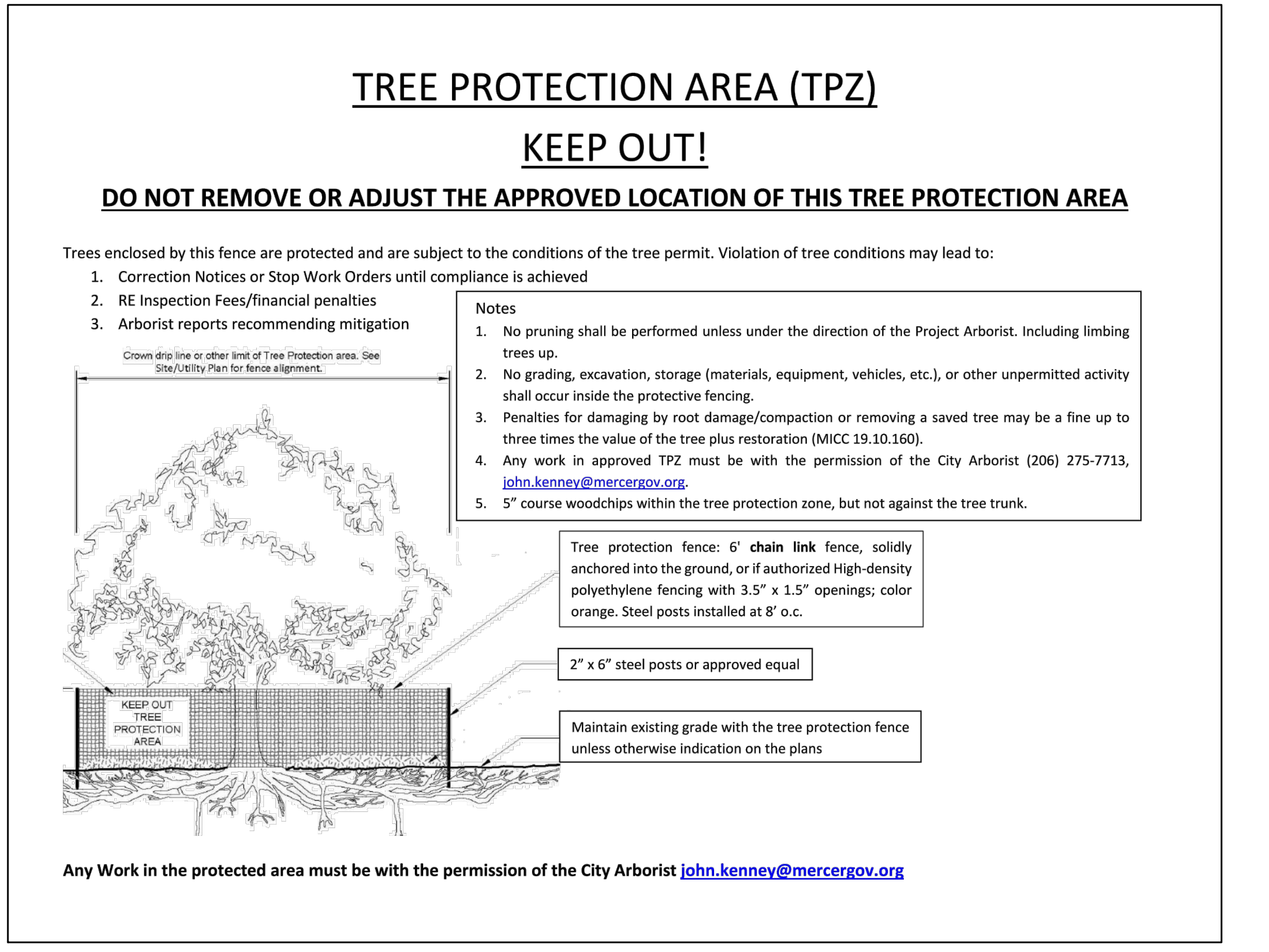

TREE PROTECTION AREA (TPZ)

KEEP OUT!

DO NOT REMOVE OR ADJUST THE APPROVED LOCATION OF THIS TREE PROTECTION AREA

Trees enclosed by this fence are protected and are subject to the conditions of the tree permit. Violation of tree conditions may lead to:

1. Correction Notices or Stop Work Orders until compliance is achieved
2. Re Inspection Fees/financial penalties
3. Arborist reports recommending mitigation

- Notes
1. No pruning shall be performed unless under the direction of the Project Arborist. Including limbing trees up.
 2. No grading, excavation, storage (materials, equipment, vehicles, etc.), or other unpermitted activity shall occur inside the protective fencing.
 3. Penalties for damaging by root damage/compaction or removing a saved tree may be a fine up to three times the value of the tree plus restoration (MICC 19.10.160).
 4. Any work in approved TPZ must be with the permission of the City Arborist (206) 275-7713, john.kennedy@mercergov.org.
 5. 2\"/>

Cover the base or other side of tree protection area. See Drawings for fence placement.

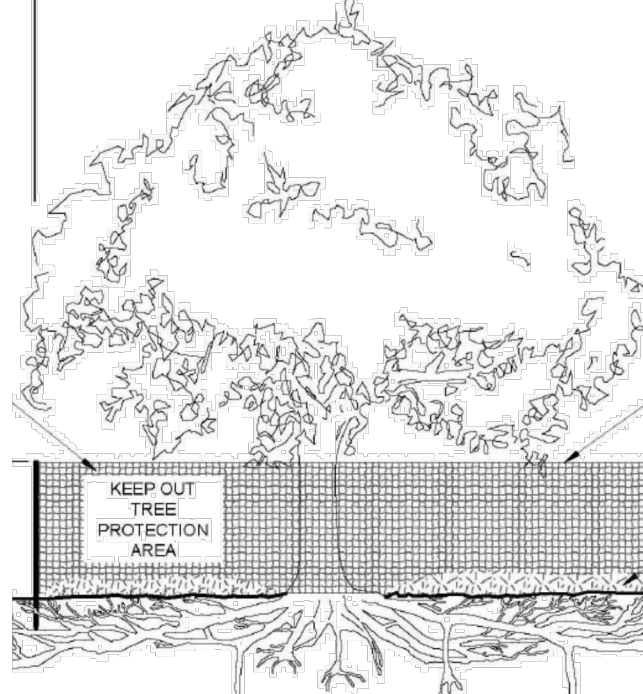

- Tree protection fence: 6\"/>
- 2\"/>
- Maintain existing grade with the tree protection fence unless otherwise indicated on the plans.

Any Work in the protected area must be with the permission of the City Arborist john.kennedy@mercergov.org

TREE PROTECTION FENCING
NTS

8
C2.50

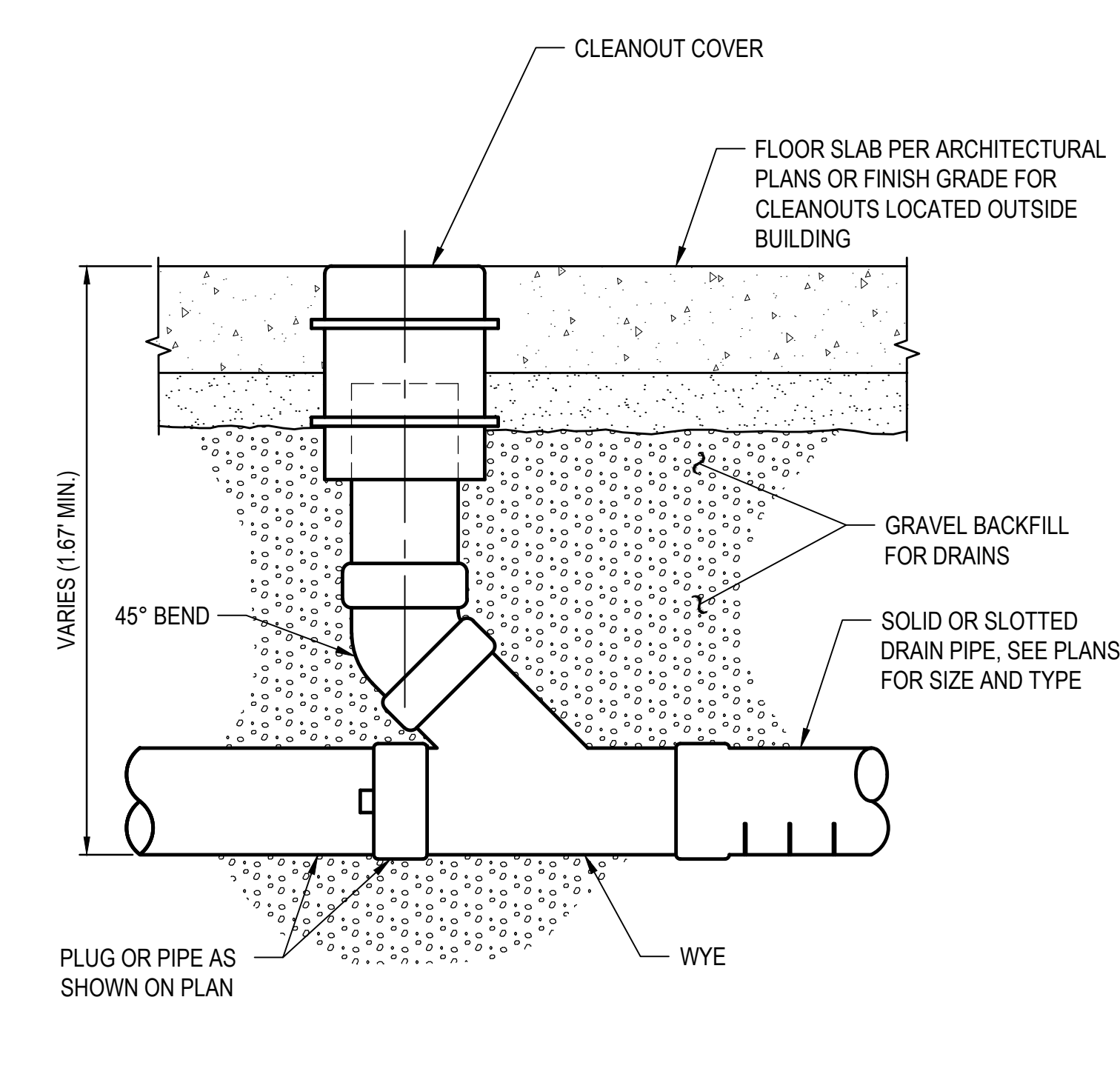

FOOTING DRAIN CLEANOUT DETAIL
NTS

9
C4.50

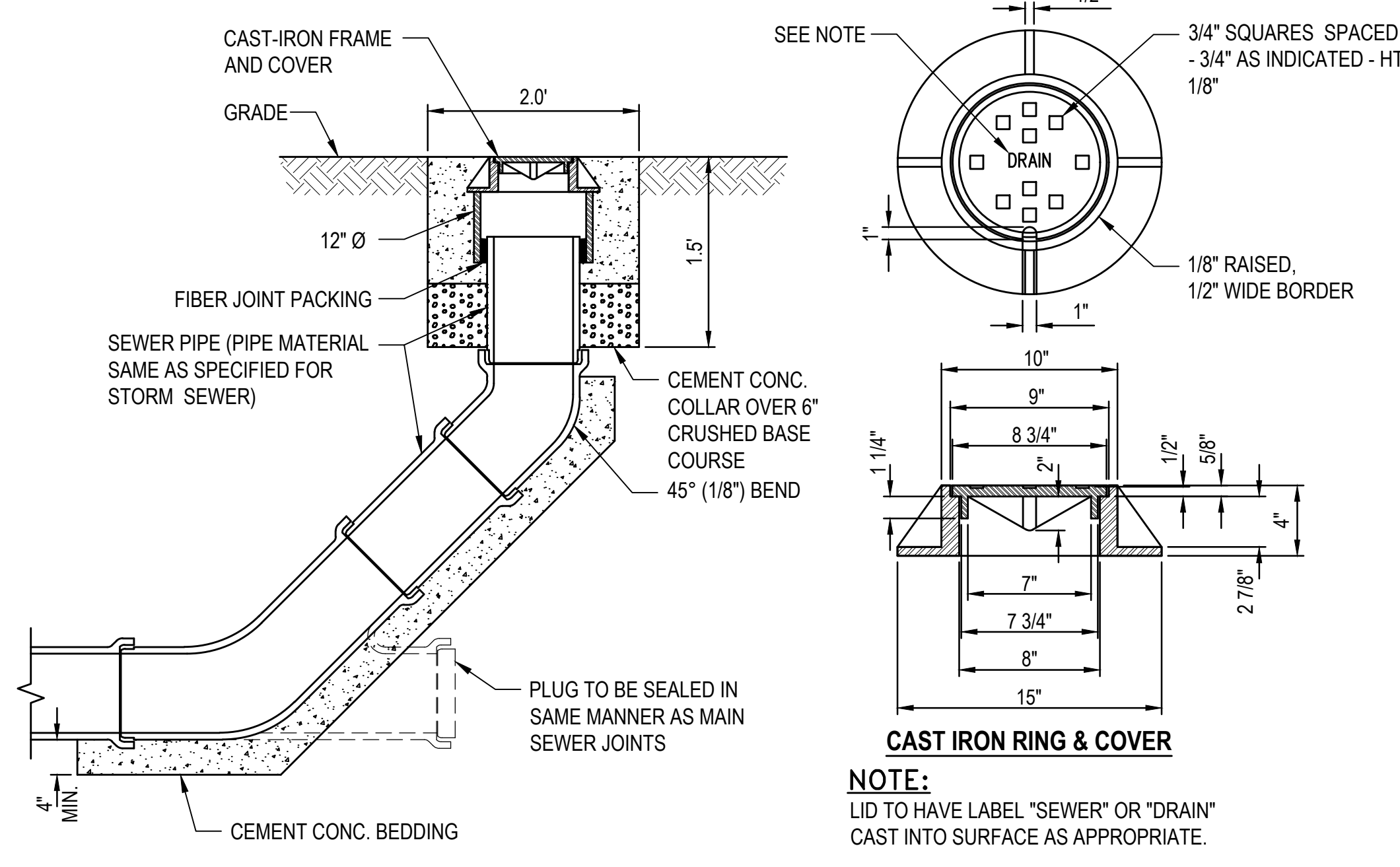

STORM DRAIN CLEANOUT
NTS

10
C4.00, C4.50

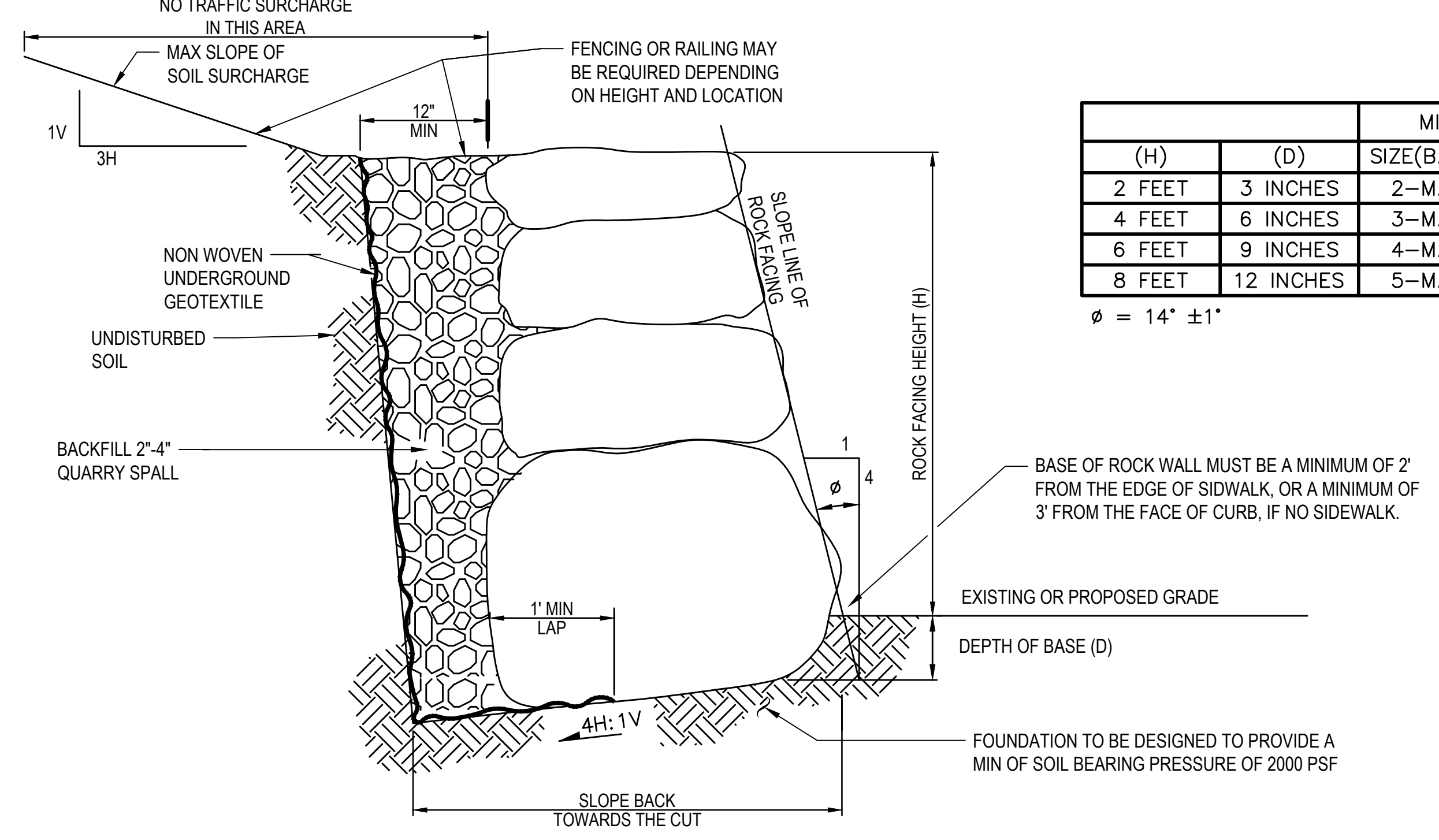

ROCKERY
NTS

11
C3.00, C4.00

(H)	(D)	MINIMUM ROCK	
		SIZE (BASE)	SIZE (TOP)
2 FEET	3 INCHES	2-MAN	1-MAN
4 FEET	6 INCHES	3-MAN	2-MAN
6 FEET	9 INCHES	4-MAN	2-MAN
8 FEET	12 INCHES	5-MAN	2-MAN

φ = 14" ± 1"

BASE OF ROCK WALL MUST BE A MINIMUM OF 2' FROM THE EDGE OF SIDEWALK, OR A MINIMUM OF 3' FROM THE FACE OF CURB, IF NO SIDEWALK.

EXISTING OR PROPOSED GRADE

DEPTH OF BASE (D)

FOUNDATION TO BE DESIGNED TO PROVIDE A MIN OF SOIL BEARING PRESSURE OF 2000 PSF

\\netf.com\Civil\22000001-22009999\2200707 Fused Elements\Design\CAD\Design\Permit\C5-00-DIV-CIVL-DET.dwg
 E:\p
 Feb 22, 2024 - 4:37pm

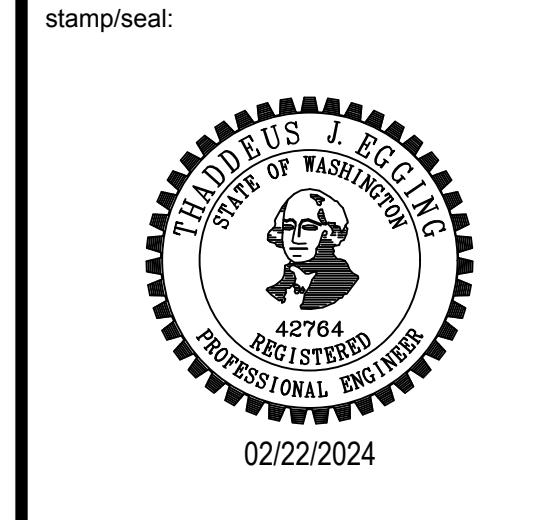

project engineer: EAP
 project manager: BCR
 drawn by: EAP/JVL
 checked by: TJE
 job no.: 2200707

revisions:

no.	date	description
1	02/23/24	R1 PERMIT

PERMIT SET
09.08.2023

title:
CIVIL DETAILS

sheet:
C5.00



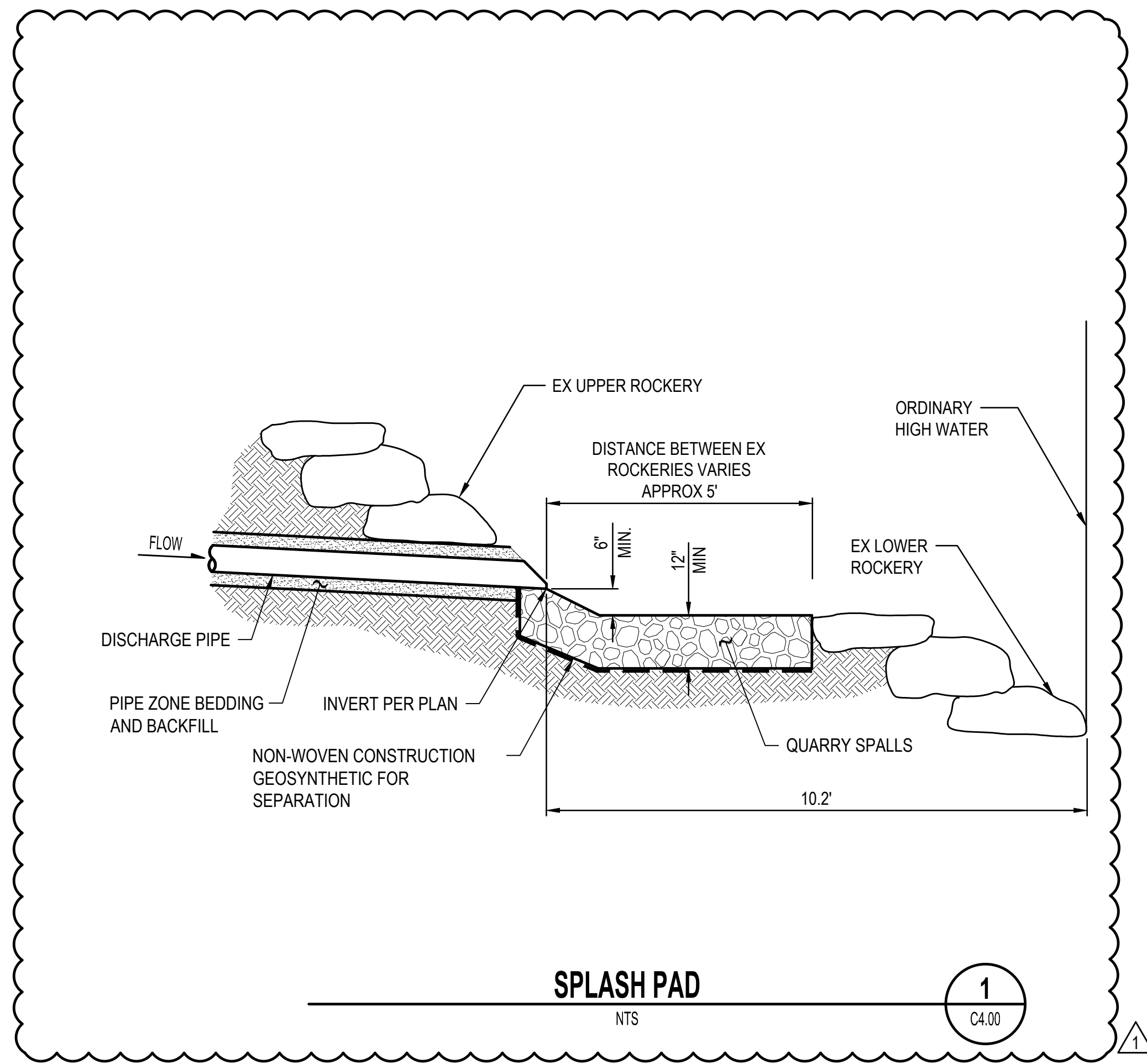

Feb 22, 2024 4:37pm E:\p \\verif.com\Civil\22000001--2209999\2200707 Fused Elements\Design\CAD\Design\Permit\CS-00-DIV-DTL-DTL.dwg

project
FUSED ELEMENTS
 4525 FOREST AVE SE MERCER ISLAND WA 98040

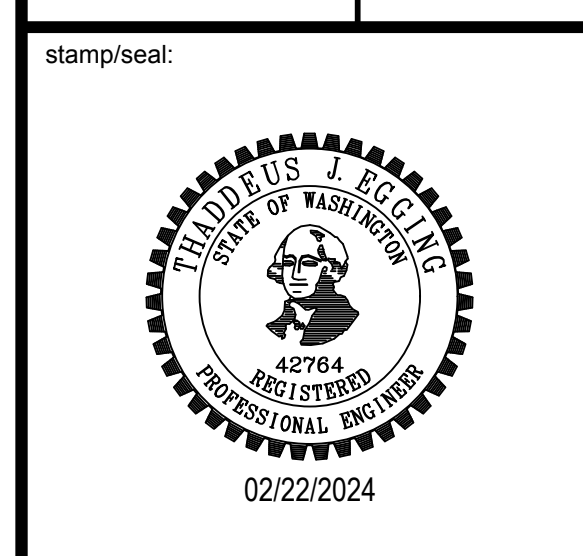

project engineer: EAP
 project manager: BCR
 drawn by: EAP/JYL
 checked by: TJE
 job no.: 2200707

revisions:

1	02/23/24	R1 PERMIT
no.:	date:	description:

PERMIT SET

09.08.2023

title:
CIVIL DETAILS

sheet:
C5.01



stamp/sign:

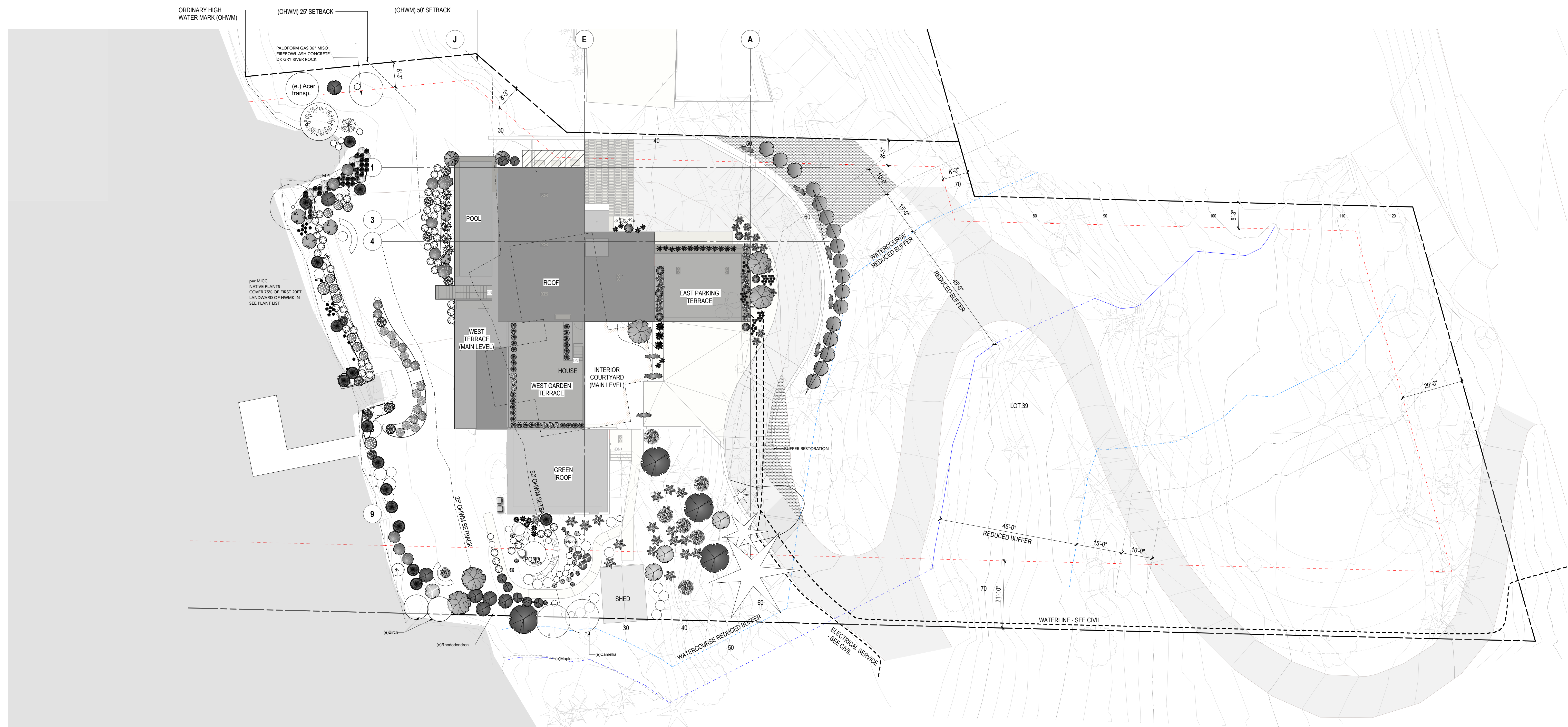

L1.00 LANDSCAPE PLAN
 SCALE: 1/8" = 1'-0"

revisions:

1	02/23/24	R1 PERMIT
no.	date:	description:

PERMIT SET
 09/08/2023

title:

LANDSCAPE PLAN

sheet:

L1.00

stamp/seal:



DESIGNATED REPLACEMENT TREE UNITS			
74 trees @ 1.25' diameter dbh			
DECIDUOUS			15 trees
(Oak / Camellia) "Native"	1 tree unit		
(Redwood) "Native"	1 tree unit		
(Alder / Black Alder)	1 tree unit		
(Rosa / Dog Rose)	1 tree unit		
(Corylus / White Willow)	1 tree unit		
(Prunella / Blackberry)	1 tree unit		
EVERGREEN			3 trees
(Picea / Fir)	1 tree unit		
(Thuja / Red Cedar)	2 trees		
Total Native Trees:			21 trees
Total Replacement Trees:			31

DESIGNATED REPLACEMENT TREES		BY TAG NUMBER	
DECIDUOUS			
(Oak / Camellia)		R44.6, 7, 10, 11, 12, 13, 14, 15, 16, 17, 18, 21, 22, 24, 25, 26, 28, 29, 30, 31, 32, 33, 34, 35, 36, 37, 38, 39, 40, 41, 42, 43, 44, 45, 46, 47, 48, 49, 50, 51, 52, 53, 54, 55, 56, 57, 58, 59, 60, 61, 62, 63, 64, 65, 66, 67, 68, 69, 70, 71, 72, 73, 74, 75, 76, 77, 78, 79, 80, 81, 82, 83, 84, 85, 86, 87, 88, 89, 90, 91, 92, 93, 94, 95, 96, 97, 98, 99, 100	
(Oak / Camellia)		R43	
(White Birch)		R48, 49, 50, 51, 52, 53, 54, 55	
(Corylus / White Willow)		R40, 41, 42, 43, 44, 45	
(Prunella)		R46, 47, 48	
EVERGREEN		R41, 25	
(Picea / Fir)		R41, 25	
(Thuja / Red Cedar)		R41, 25	
Total Replacement Trees:			31

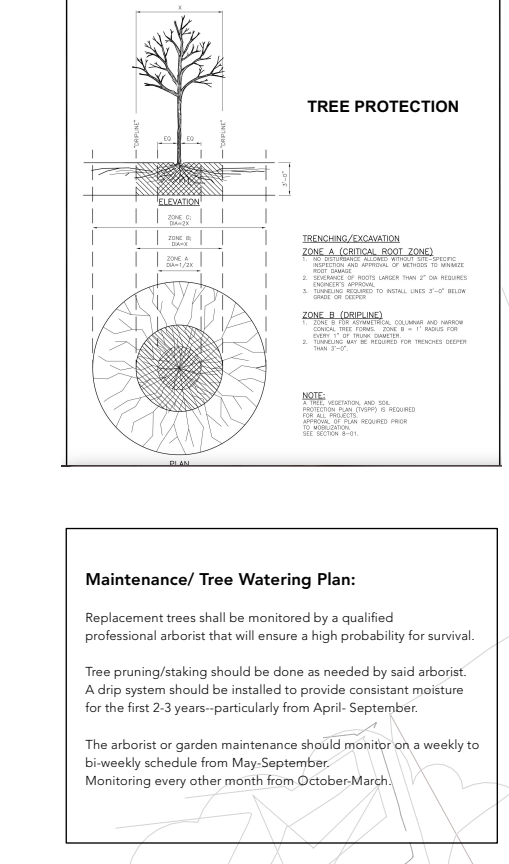

project architect:
project manager:
drawn by:
checked by:
job no.:

revisions:	

1 02/23/24 R1 PERMIT
no. date description:

PERMIT SET
09/08/2023

TREE REPLACEMENT PLAN

sheet:
L1.01

L1.00 LANDSCAPE PLAN
SCALE: 1/8" = 1'-0"

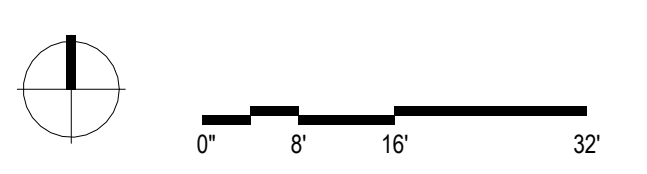



project architect:
project manager:
drawn by:
checked by:
job no.:

revisions:

1 02/23/24 R1 PERMIT
no. date description:

PERMIT SET
09/08/2023

title:
LANDSCAPE/HARDSCAPE PLAN

sheet:
L1.02

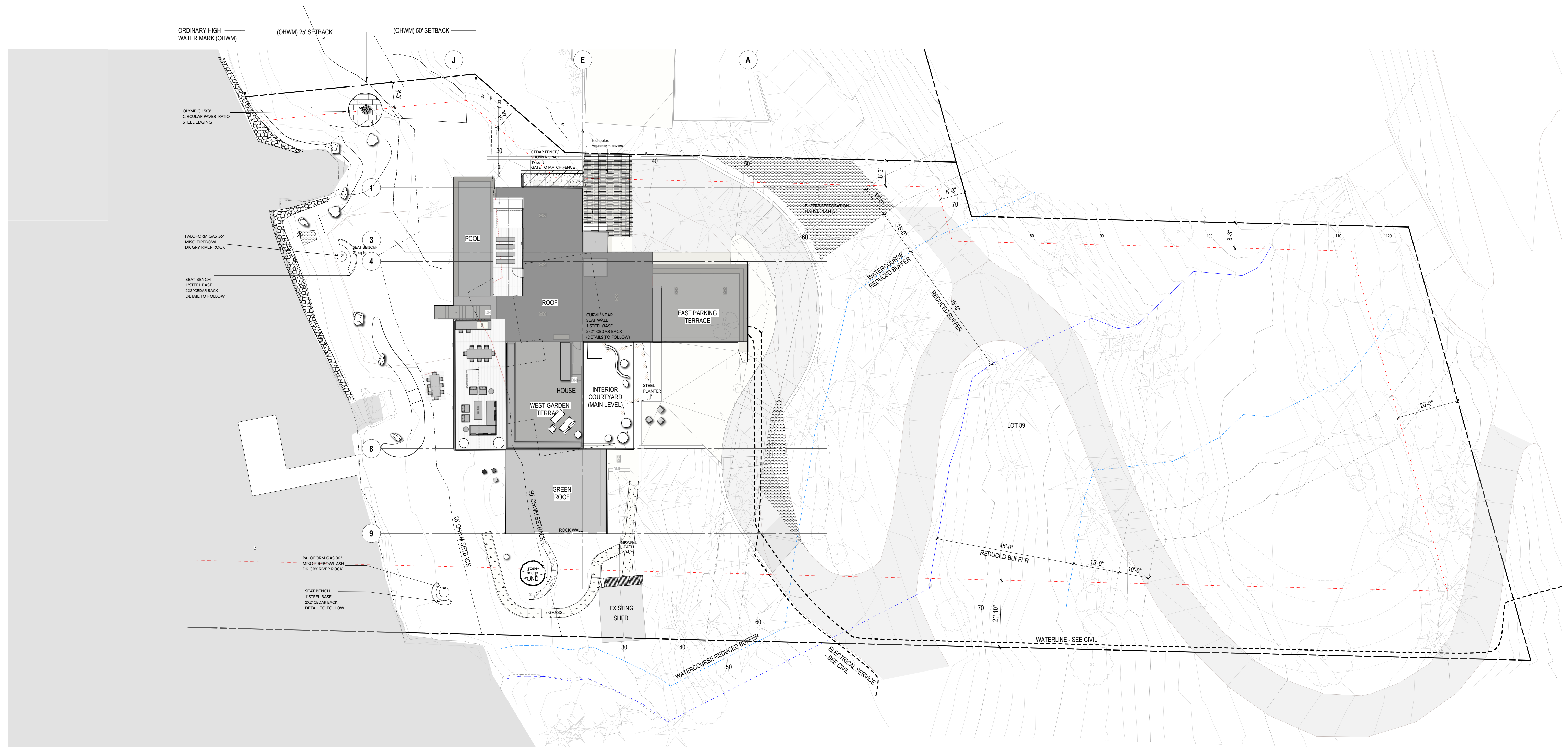

1.02 LANDSCAPE/HARDSCAPE PLAN
SCALE: 1/16" = 1'-0"

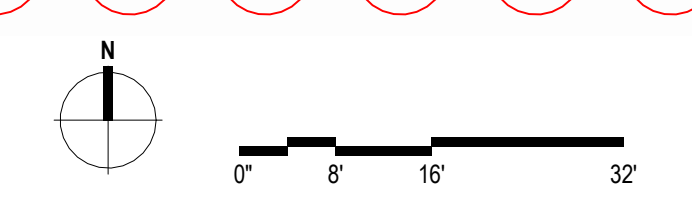



WEST ELEVATION



ENTRY LOOKING EAST



ENTRY LOOKING SOUTH



WEST ROOF TERRACE



COURTYARD LOOKING NORTH

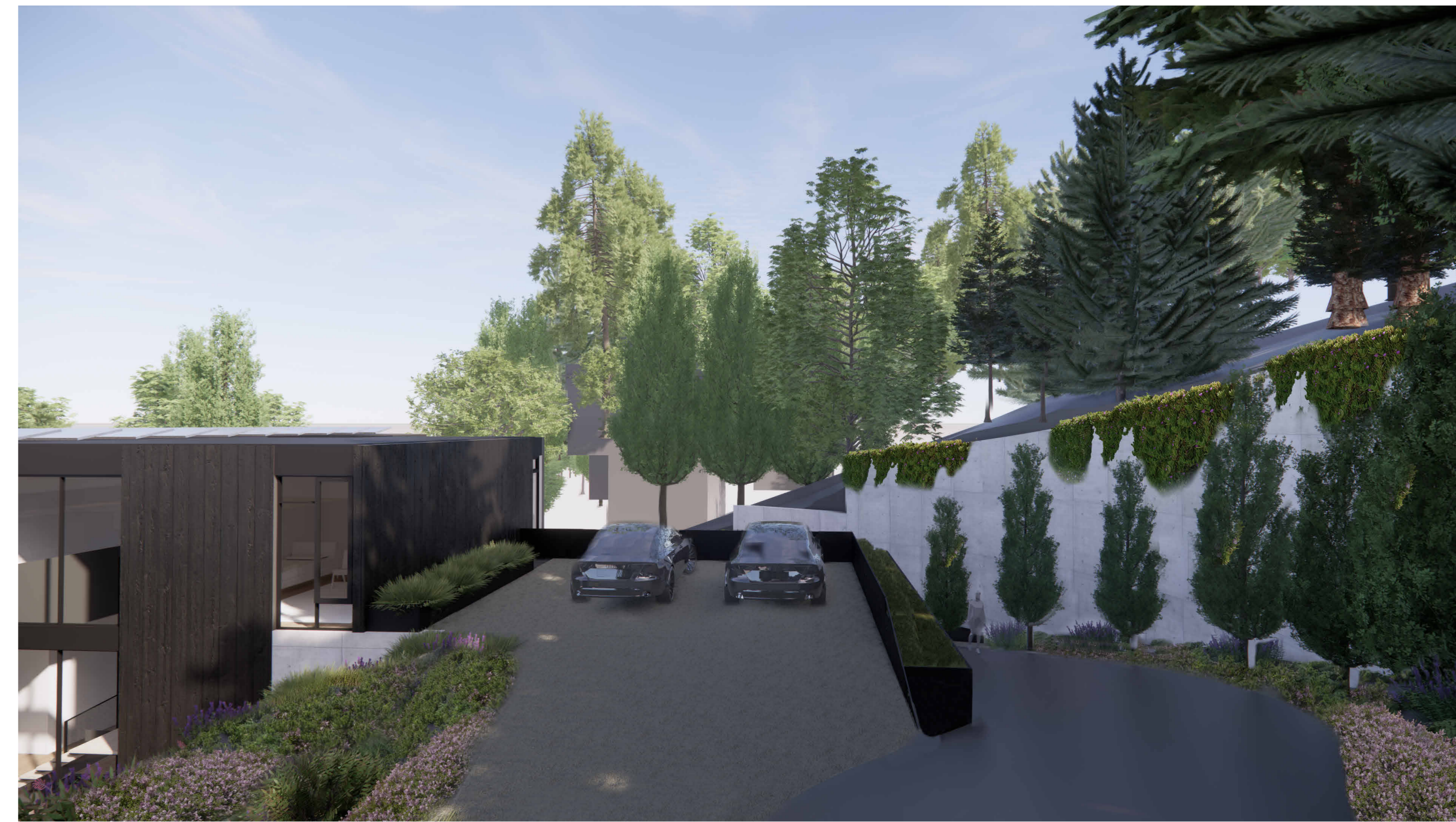

EAST PARKING TERRACE

199 South Juniper St, Suite 800
Seattle, Washington 98104
Tel: 206.461.2171
www.olsonkundig.com
Olson Kundig
project:
FUSED ELEMENTS
4525 FOREST AVE SE MERCER ISLAND, WA 98040

stamp/seal:

2024 REGISTERED ARCHITECT
tankmich
 STATE OF WASHINGTON

project architect: _____
project manager: _____
drawn by: _____
checked by: _____
job no.: _____

revisions:

<small>no.:</small>	<small>date:</small>	<small>description:</small>

<small>PERMIT SET</small> <small>09/08/2023</small>
<small>ISSUE:</small> BUILDING PERSPECTIVES
<small>sheet:</small> A0.02

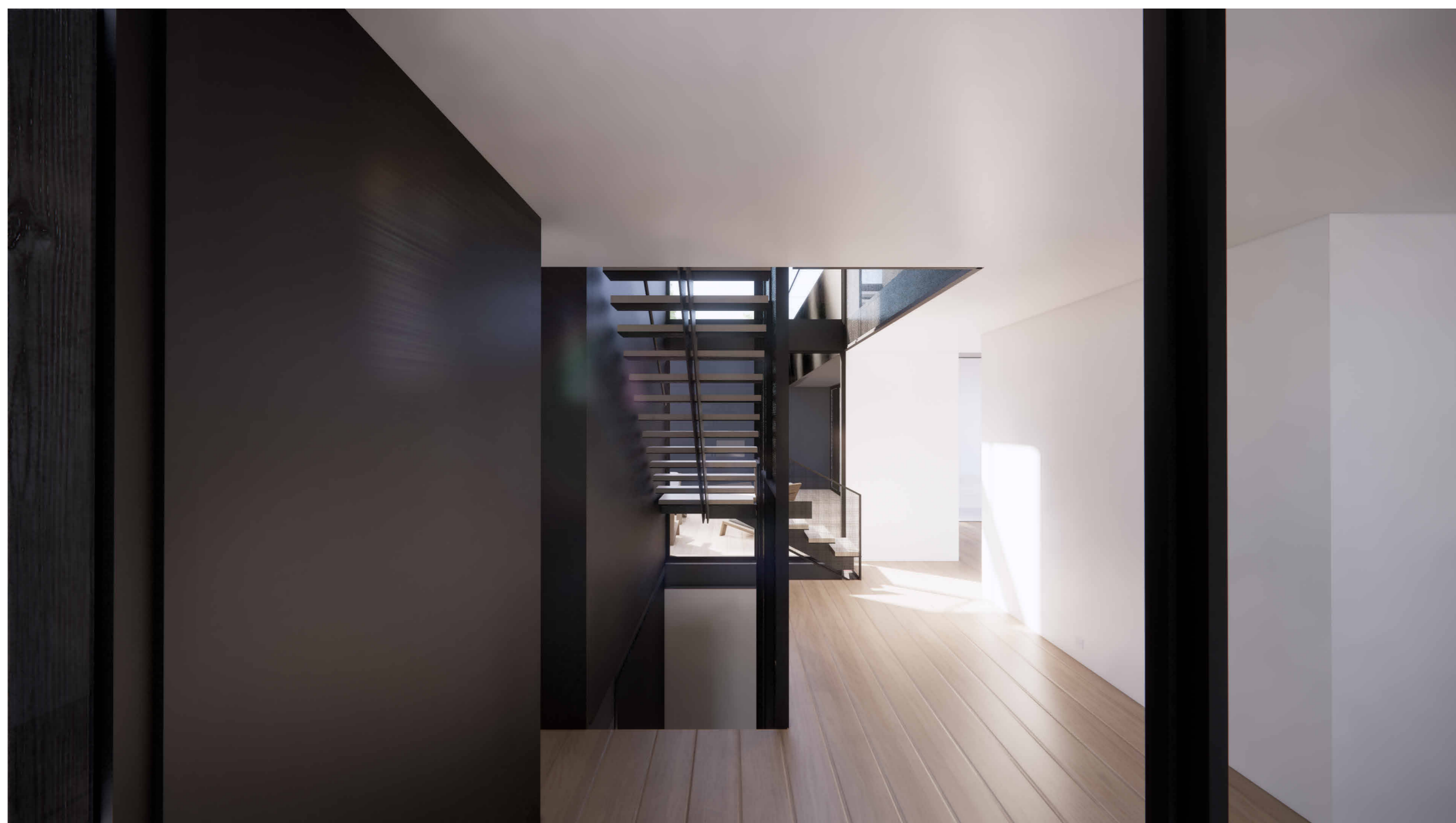

ENTRY LOOKING SOUTH



LIVING LOOKING SOUTH



WEST TERRACE



PRIMARY LOOKING WEST



LOOKING AT KITCHEN

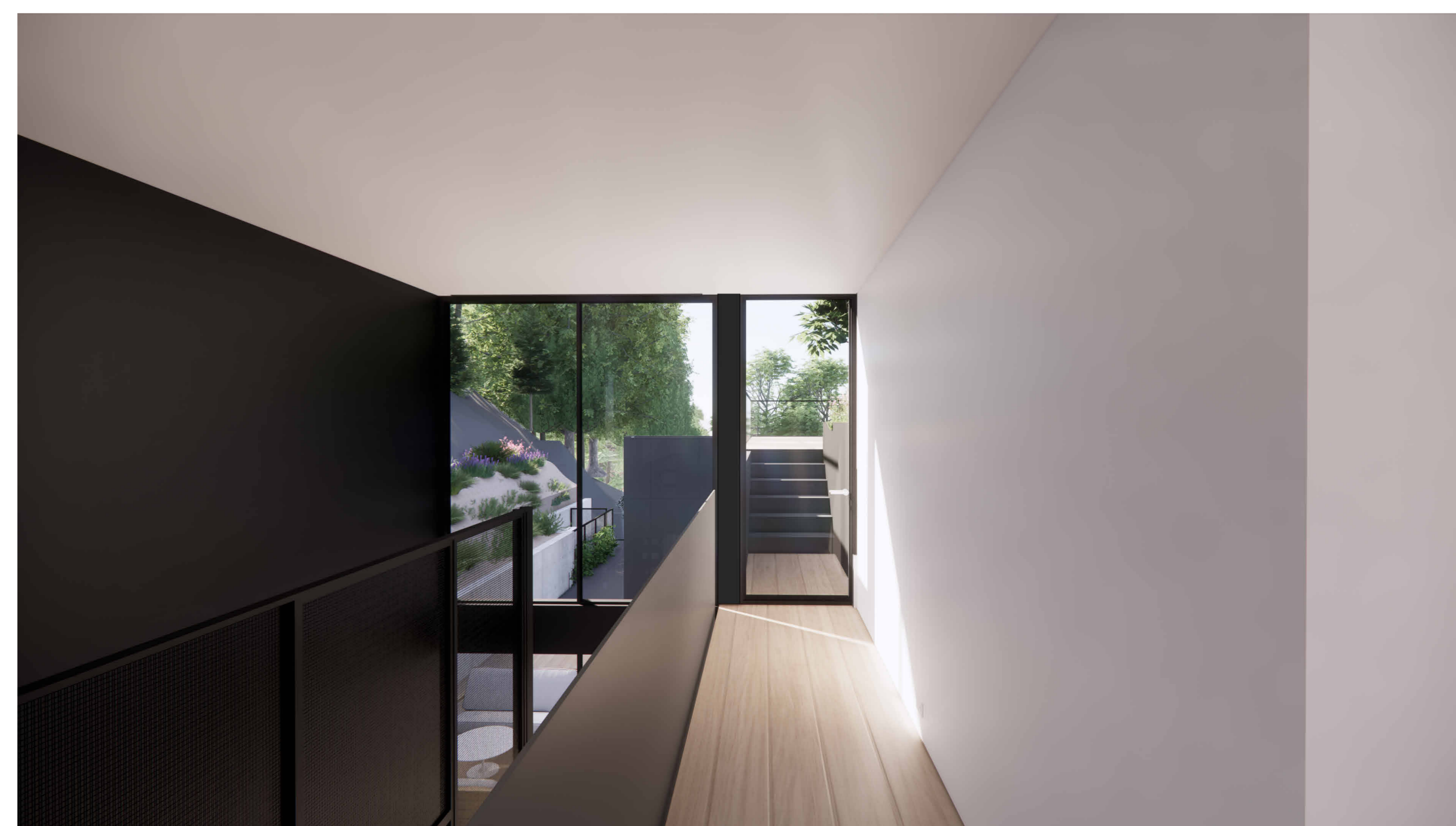

STAIR TO WEST ROOF TERRACE

155 South Jackson St. Suite 1000
Seattle, Washington 98104 USA
Tel: 206 467 4979 | olsonkundig.com

Olson Kundig

PROJECT: FUSED ELEMENTS

4525 FOREST AVE SE MERCER ISLAND, WA 98040

stamp/seal:



project architect: _____
project manager: _____
drawn by: _____
checked by: _____
job no.: _____

revisions:

no.: date: description:

PERMIT SET
09/08/2023

550:
**BUILDING
PERSPECTIVES**

sheet:
A0.03

SHEET NOTES
1. SEE SHEET A0.24 FOR WINDOW AND DOOR SCHEDULES.

WINDOW LEGEND

E	EMERGENCY EGRESS LOCATION
SG	PROVIDE SAFETY GLAZING WHERE REQUIRED BY CODE

155 South Juniper St, Suite 800
Seattle, Washington 98104
1-206-441-2211
olsonkundig.com

Olson Kundig

Project:
FUSED ELEMENTS
4525 FOREST AVE SE MERCER ISLAND, WA 98040

stamp/ seal:



2014 REGISTERED ARCHITECT
STATE OF WASHINGTON

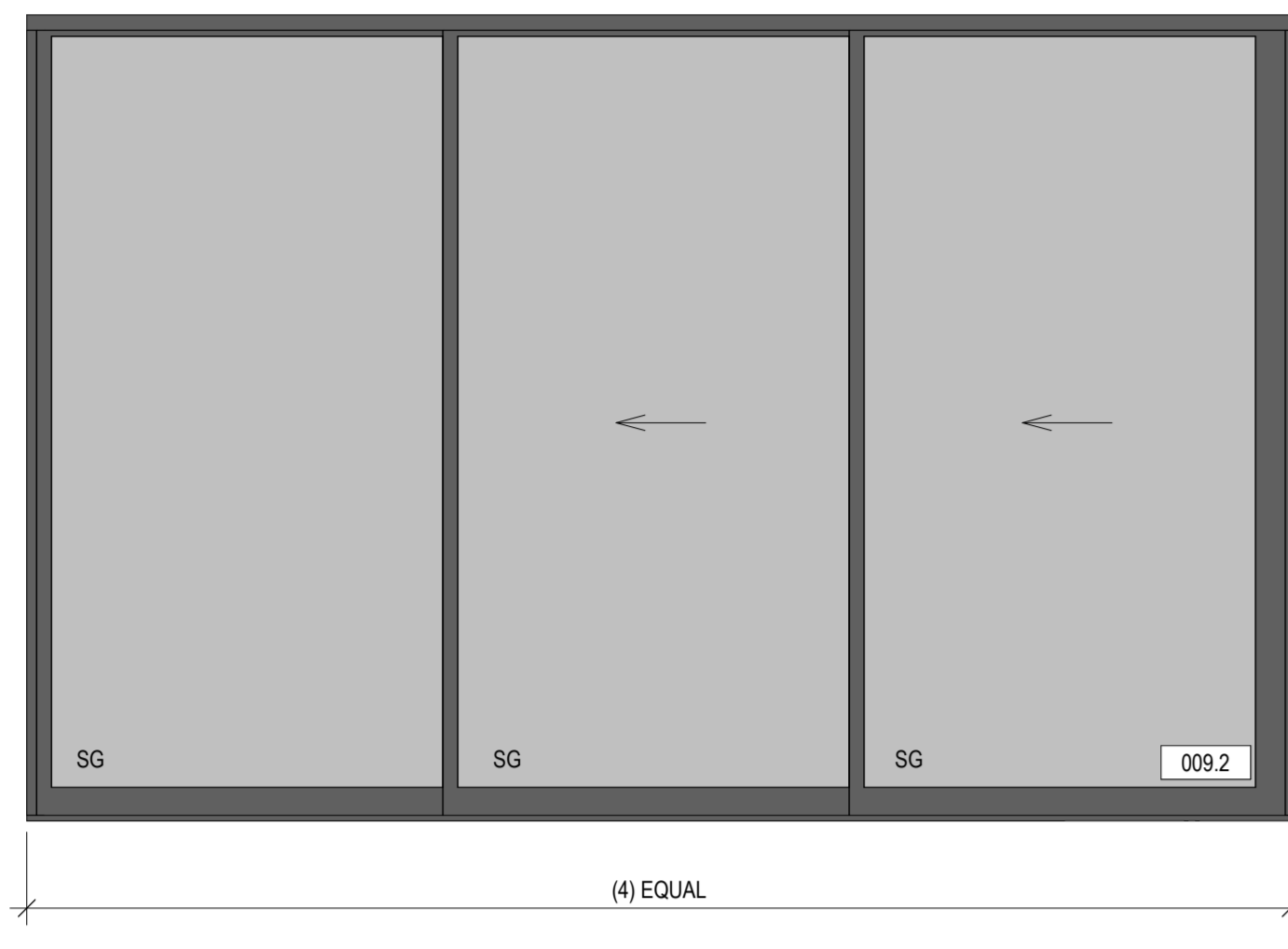

15 WEST - GYM
SCALE: 1/2" = 1'-0"

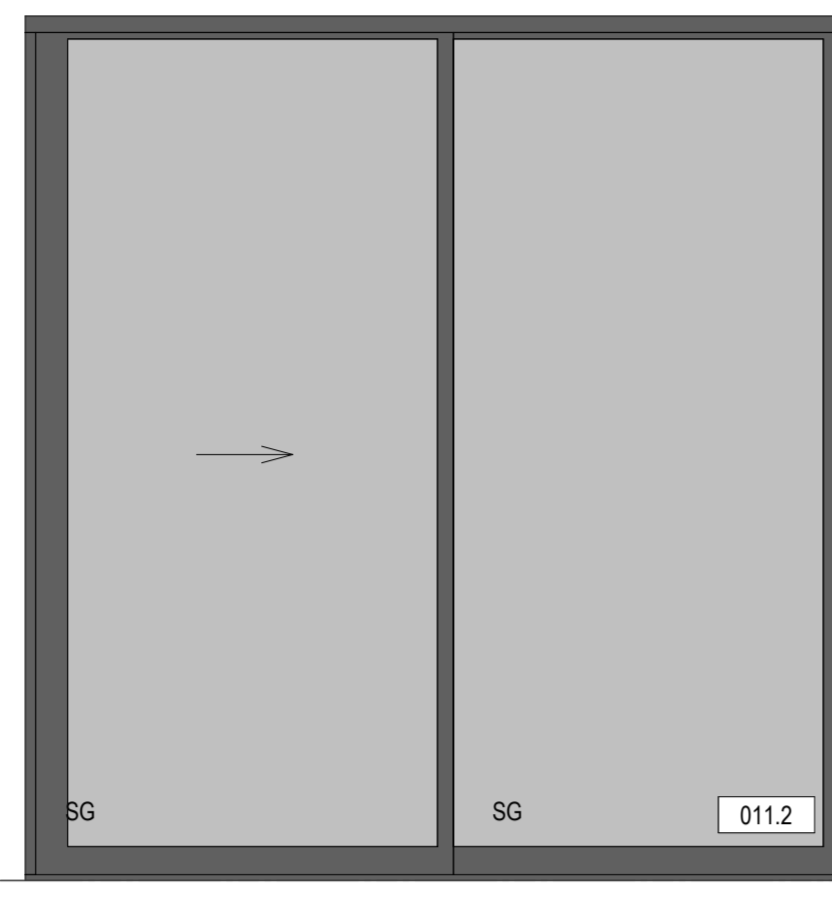

14 WEST - STUDIO
SCALE: 1/2" = 1'-0"

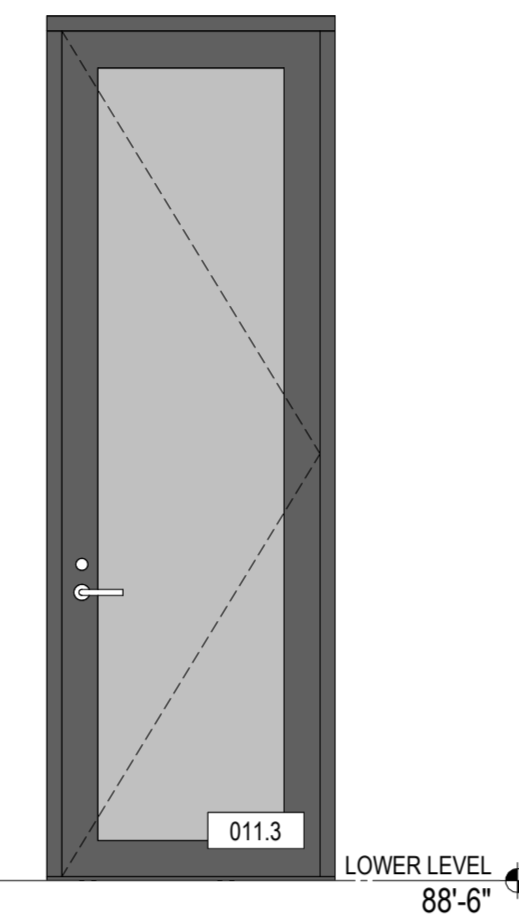

13 SOUTH - STUDIO
SCALE: 1/2" = 1'-0"

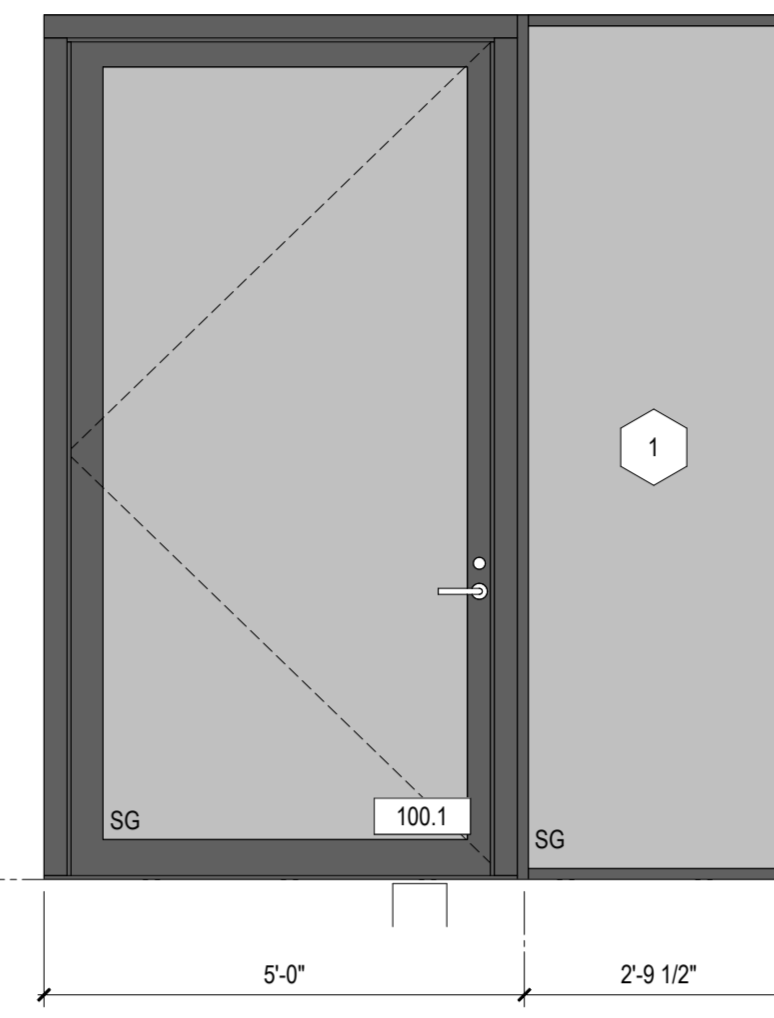

12 NORTH - ENTRY
SCALE: 1/2" = 1'-0"

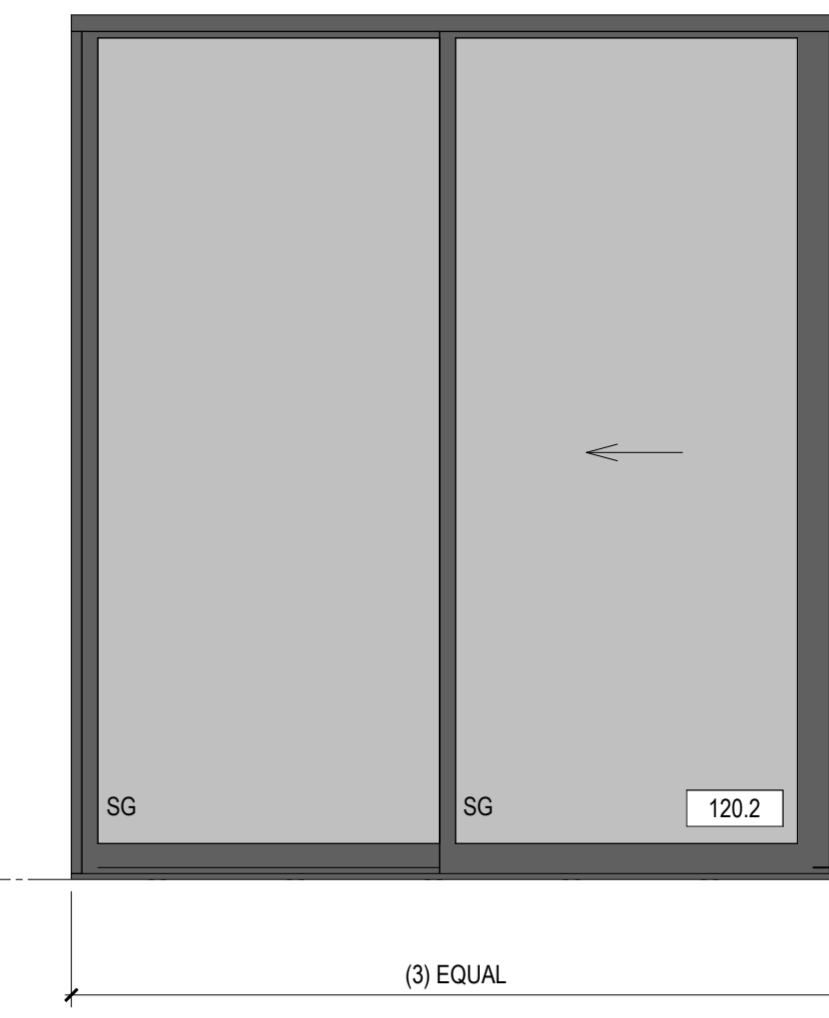

11 WEST - MEDIA
SCALE: 1/2" = 1'-0"

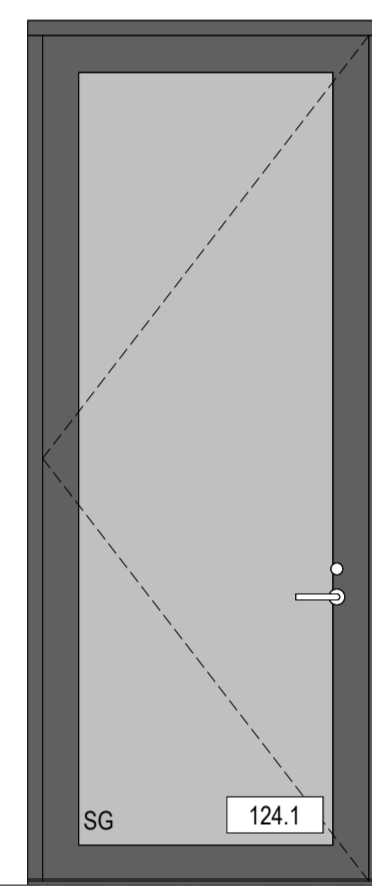

10 WEST - HALL
SCALE: 1/2" = 1'-0"

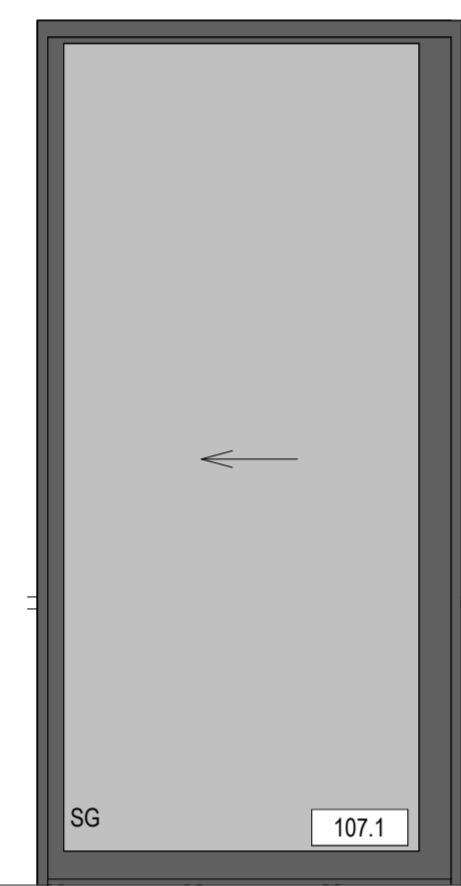

9 NORTH - KITCHEN
SCALE: 1/2" = 1'-0"



8 WEST - KITCHEN
SCALE: 1/2" = 1'-0"



7 WEST - LIVING
SCALE: 1/2" = 1'-0"

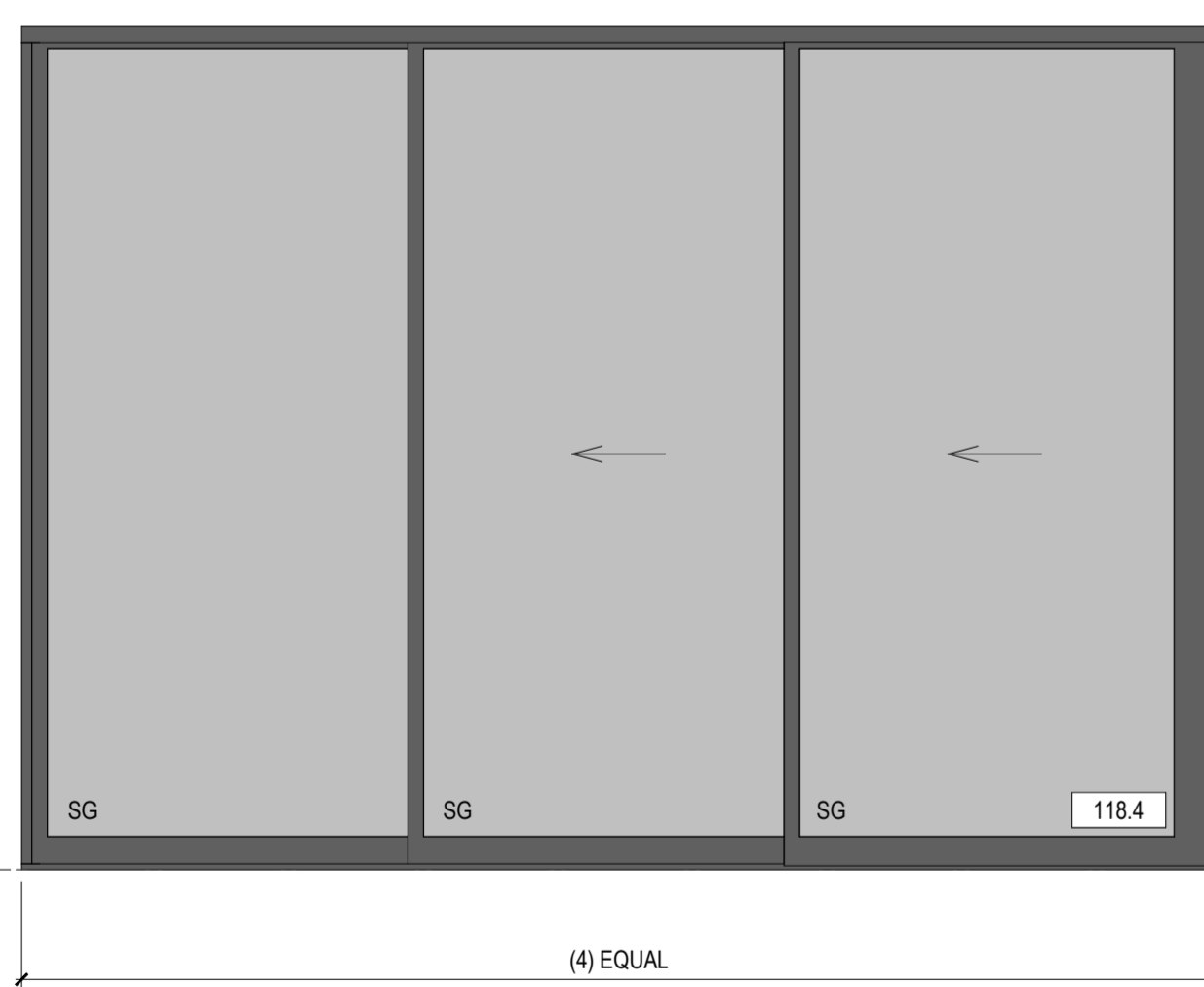

6 WEST E - PRIMARY SLIDING
SCALE: 1/2" = 1'-0"

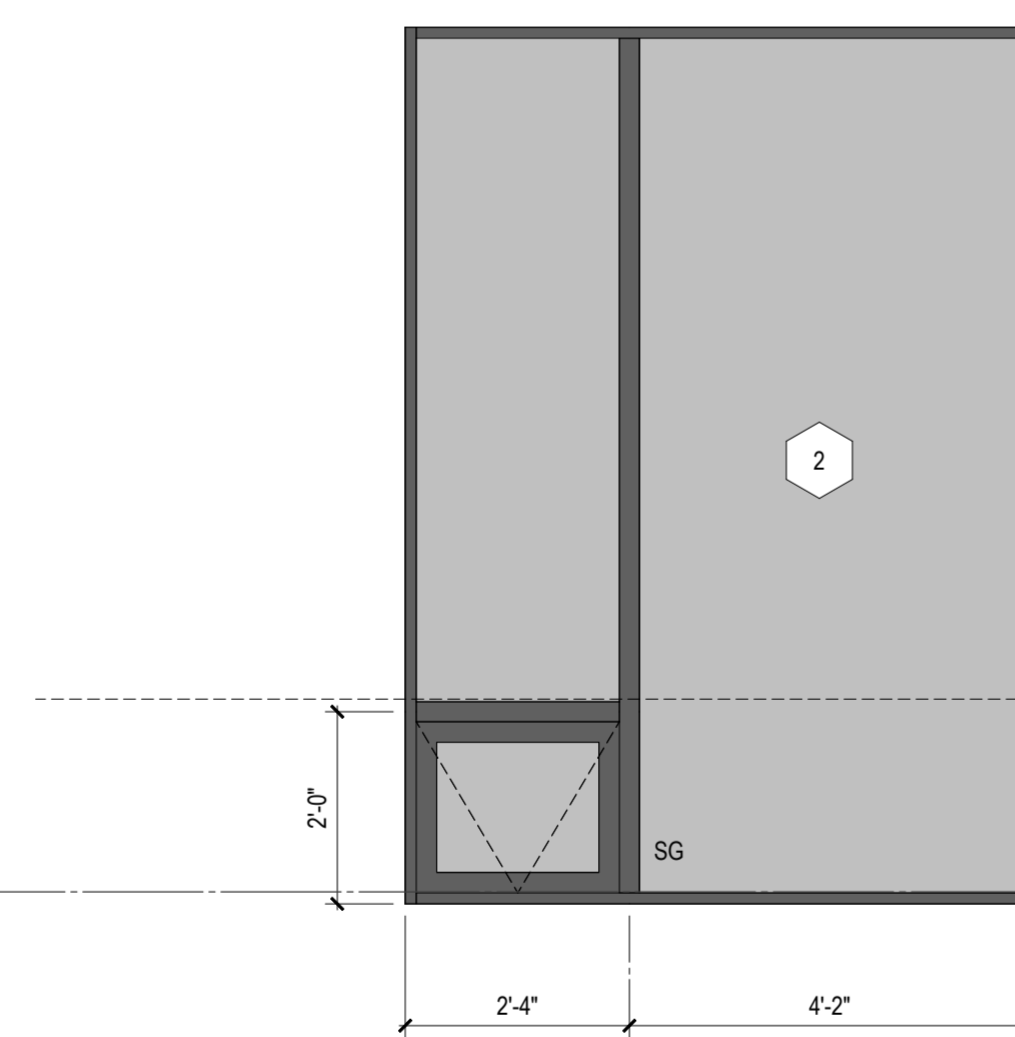

5 WEST - PRIMARY
SCALE: 1/2" = 1'-0"

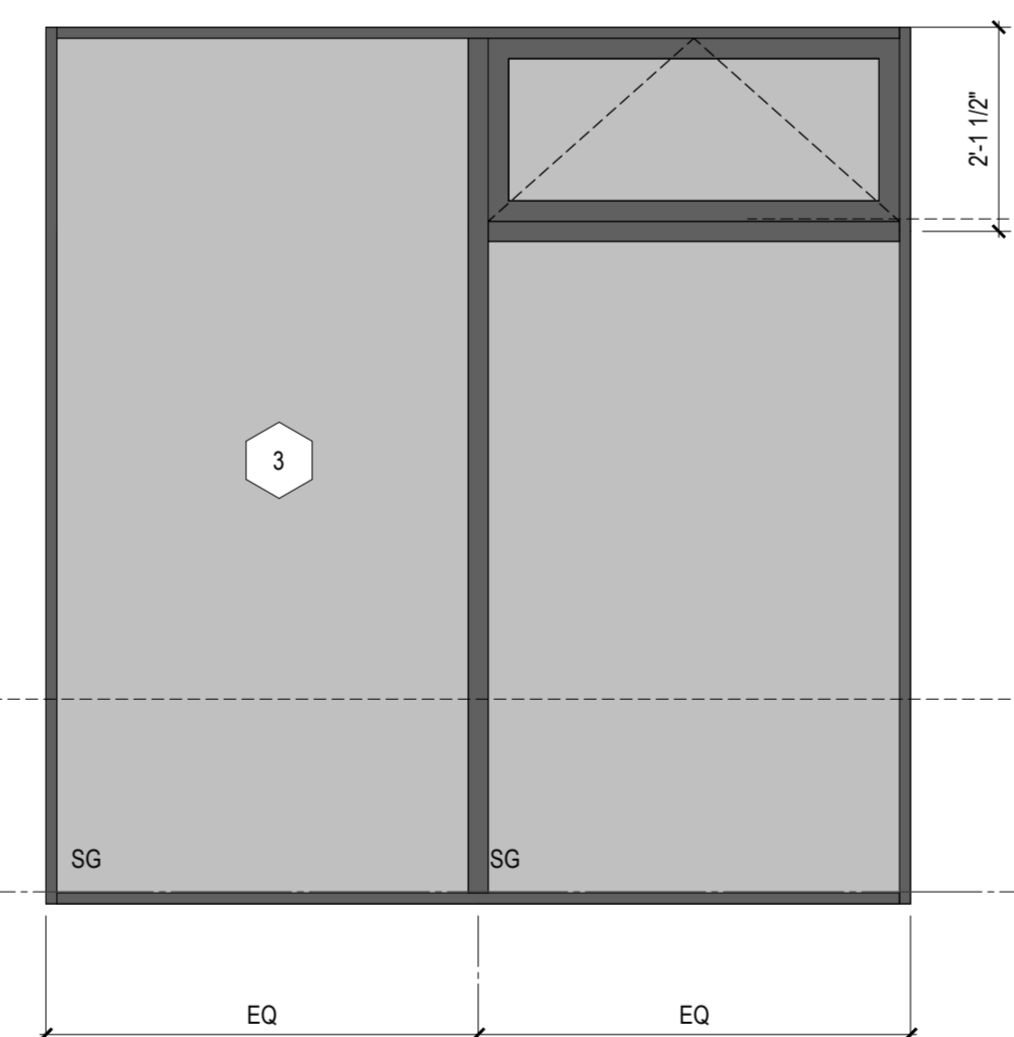

4 SOUTH - PRIMARY
SCALE: 1/2" = 1'-0"

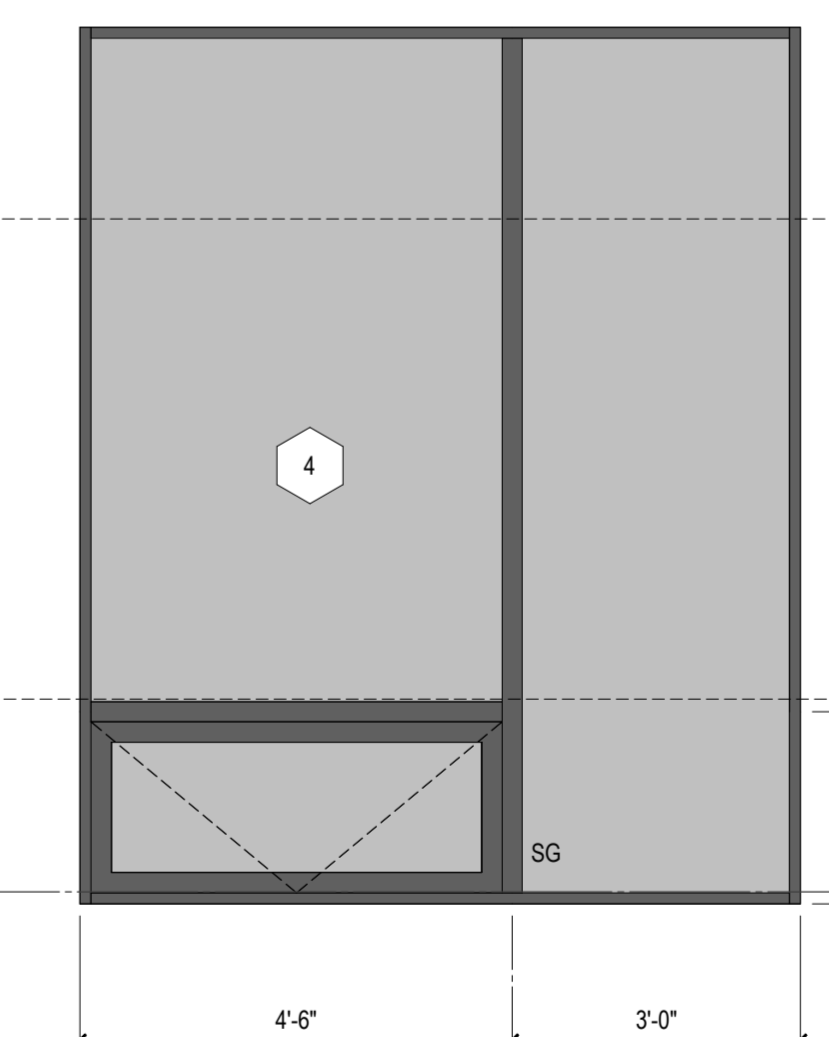

3 SOUTH - PRIMARY BATH
SCALE: 1/2" = 1'-0"

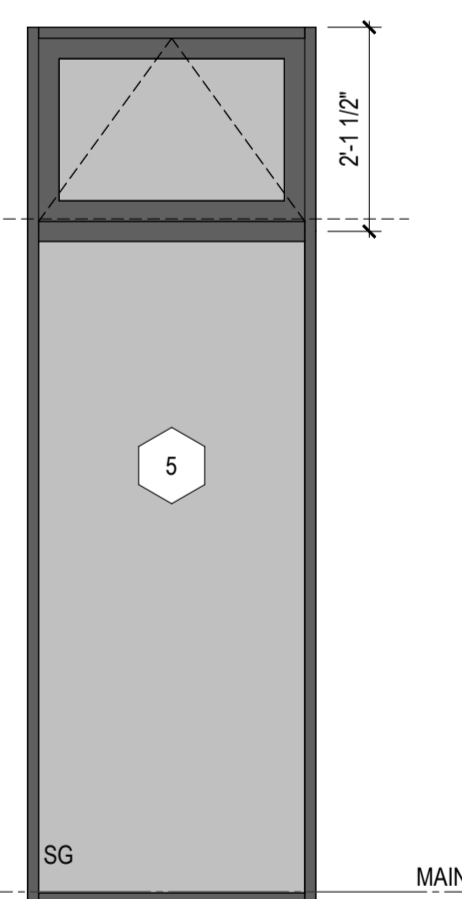

2 SOUTH - LAUNDRY
SCALE: 1/2" = 1'-0"

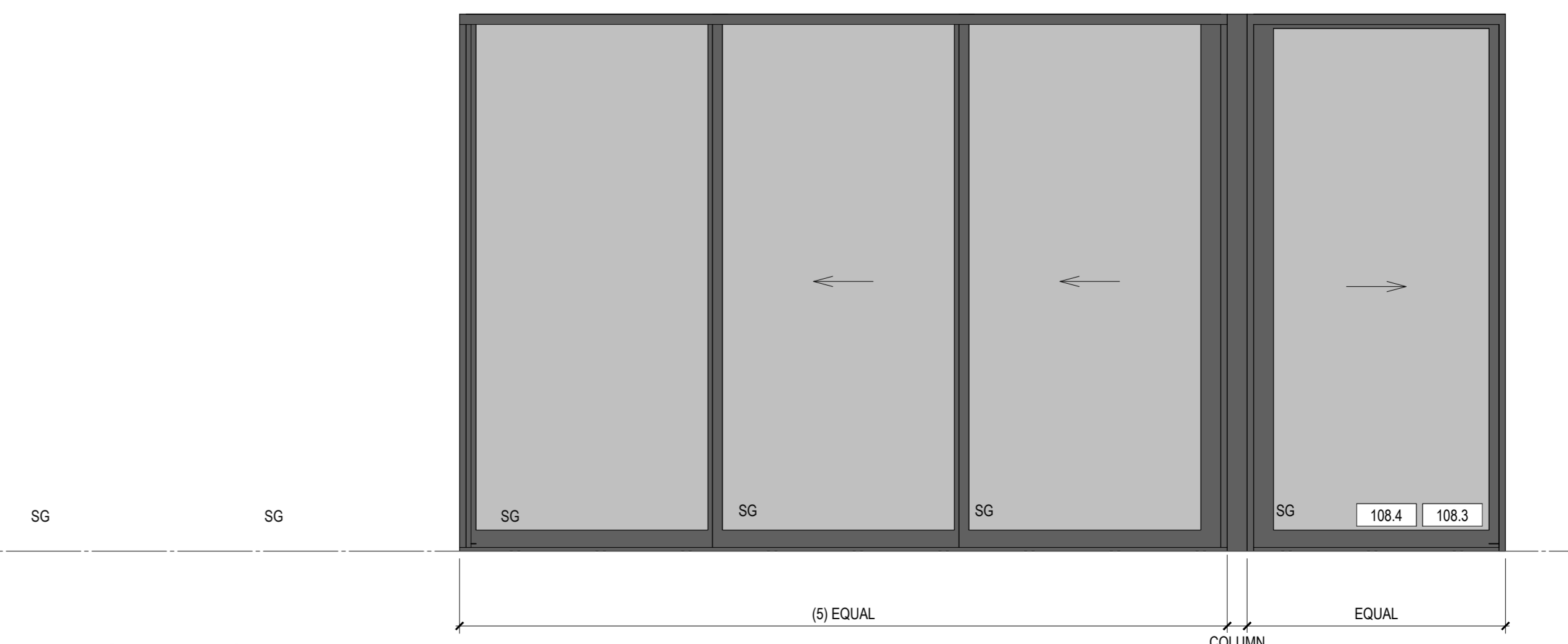

1 EAST - LIVING
SCALE: 1/2" = 1'-0"

project architect: _____
project manager: _____
drawn by: _____
checked by: _____
job no.: _____

revisions:

no. date description

PERMIT SET
09/08/2023

ISSUE

WINDOW SCHEDULES

sheet: **A0.20**

SHEET NOTES

1. SEE SHEET A0.24 FOR WINDOW AND DOOR SCHEDULES.

WINDOW LEGEND

E EMERGENCY EGRESS LOCATION
 SG PROVIDE SAFETY GLAZING WHERE REQUIRED BY CODE

1515 South Juniper St. Suite 600
 Seattle, Washington 98148 USA
 P: (206) 461-2112
 www.olsonkundig.com

Olson Kundig
 PROJECT: FUSED ELEMENTS
 4525 FOREST AVE SE MERCER ISLAND WA 98040

stamp/seal:

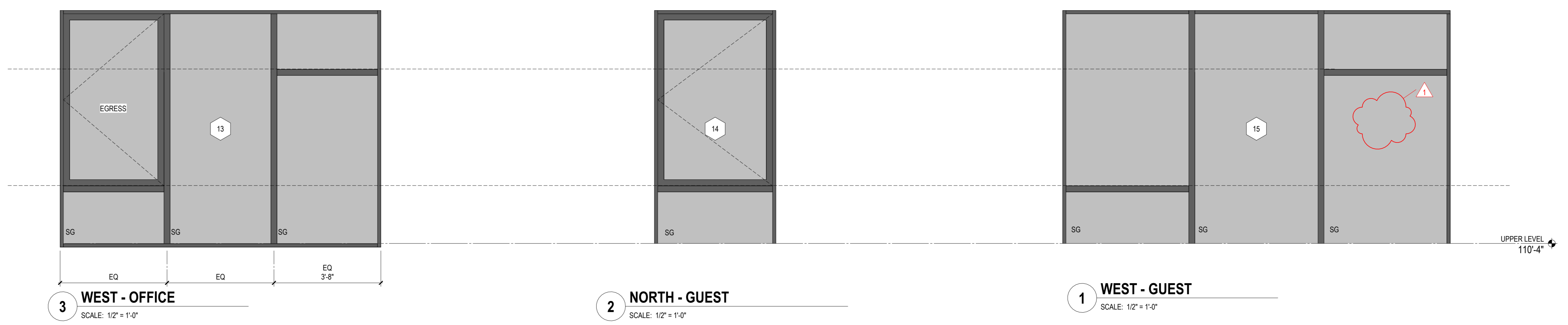
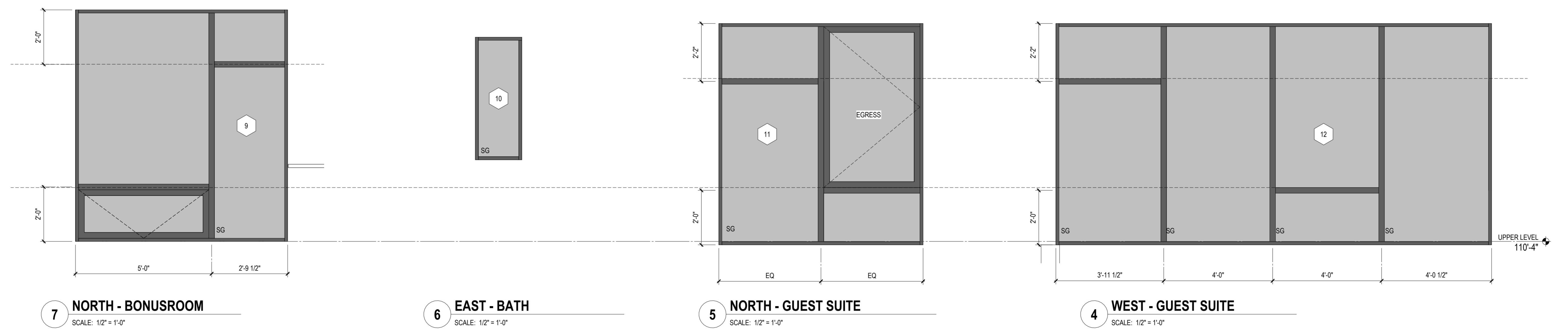
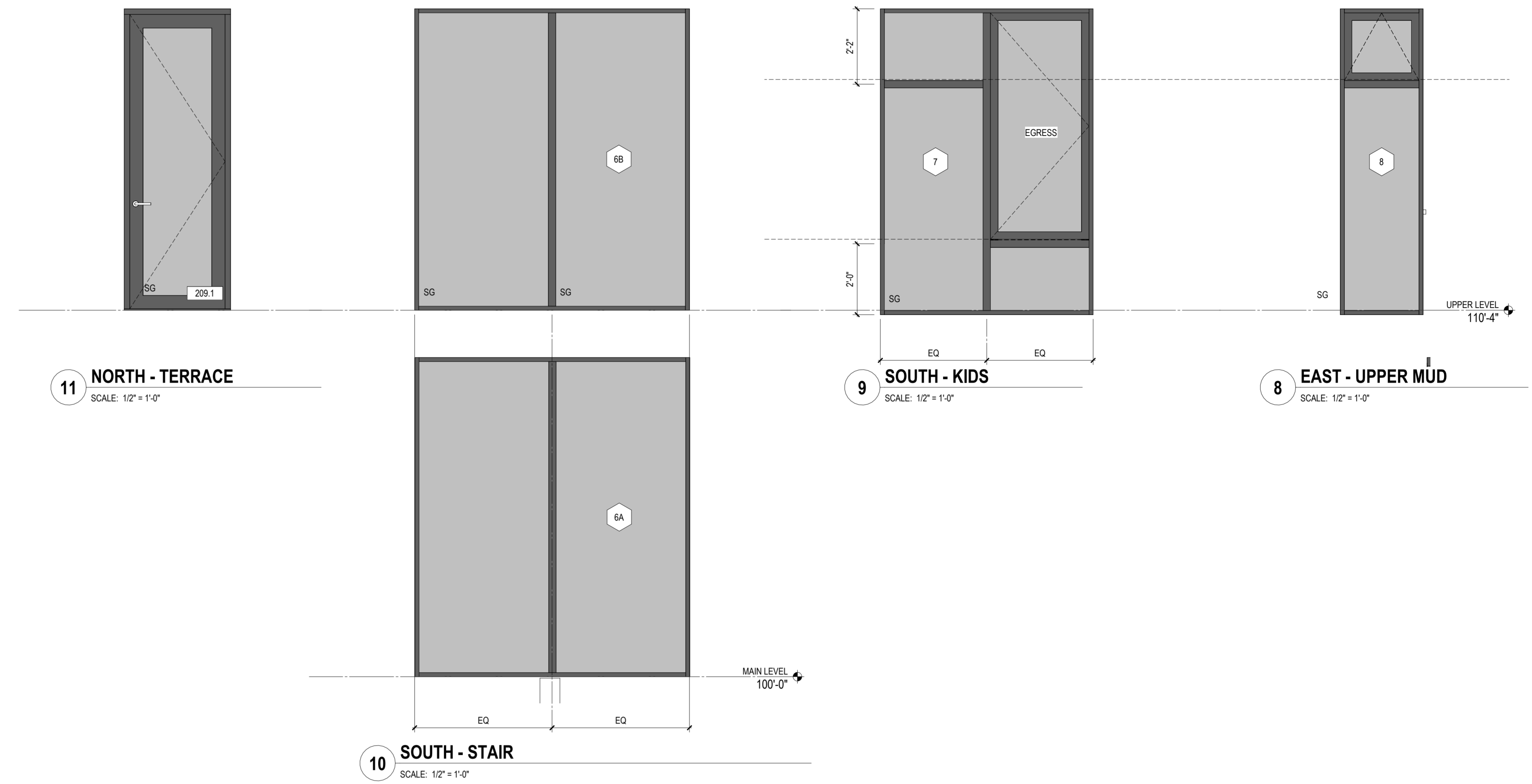

project architect: _____
 project manager: _____
 drawn by: _____
 checked by: _____
 job no.: _____

revisions:

1 02/23/24 R1 PERMIT
 no. date description

PERMIT SET
 09/08/2023

150:

WINDOW SCHEDULES

sheet:
A0.21

INTERIOR DOOR SCHEDULE											
REF.	LOCATION	ROOM NUMBER	OPERATION	TYPE	DIMENSIONS			UNDERCUT	FINISH	FRAME	REMARKS
					WIDTH (PANEL 1)	HEIGHT	THICKNESS				
LOWER LEVEL											
001.1	PLAINTROOM	004	SWING	A	3'-0"	8'-0"	1 3/4"	12"	WOOD	WOOD	
002.1	STORAGE	002	POCKET	B	3'-0"	9'-0"	1 3/4"	12"	WOOD	WOOD	
003.1	POOL/SPA/MECHANICAL	005	SWING	A	3'-0"	6'-0"	1 3/4"	12"	FIBERGLASS	HMF	
004.1	PLAINTROOM	004	SWING	A	4'-0"	8'-11"	1 3/4"	12"	WOOD	WOOD	
005.1	POOL/SPA/MECHANICAL	005	SWING	A	4'-0"	8'-11"	1 3/4"	12"	WOOD	WOOD	
006.1	BASE BATH	006	SWING	A	3'-0"	8'-11"	1 3/4"	12"	WOOD	WOOD	
008.1	OWN	009	SWING	A	4'-0"	8'-11"	1 3/4"	12"	WOOD	WOOD	
009.1	KLN	000	SWING	A	2'-6"	8'-11"	1 3/4"	12"	WOOD	WOOD	
011.1	JUDY'S STUDIO	011	SWING	A	3'-0"	8'-11"	1 3/4"	12"	WOOD	WOOD	
MAIN LEVEL											
103.1	MUD ROOM	103	SWING	A	3'-0"	8'-0"	1 3/4"	12"	WOOD	WOOD	
103.1	MUD ROOM	103	SWING	A	3'-0"	8'-0"	1 3/4"	12"	WOOD	WOOD	SELF-CLOSING SELF LATCHING
106.1	PANTRY	106	POCKET	B	3'-4"	8'-11"	1 3/4"	12"	WOOD	WOOD	
108.2	PANTRY	108	POCKET	B	3'-4"	8'-11"	1 3/4"	12"	WOOD	WOOD	
112.1	LAUNDRY	112	POCKET	B	3'-0"	8'-11"	1 3/4"	12"	WOOD	WOOD	
113.1	MUD ROOM	113	SWING	A	3'-0"	8'-0"	1 3/4"	12"	WOOD	WOOD	
118.1	PRIMARY BATH	118	POCKET	B	2'-6"	8'-11"	1 3/4"	12"	WOOD	WOOD	
117.1	WC	117	POCKET	B	2'-6"	8'-11"	1 3/4"	12"	WOOD	WOOD	
118.1	PRIMARY BEDROOM	118	SWING	A	3'-0"	8'-11"	1 3/4"	0"	WOOD	WOOD	
118.2	PRIMARY BEDROOM	118	POCKET	B	2'-6"	8'-11"	1 3/4"	12"	WOOD	WOOD	
118.3	PRIMARY BEDROOM	118	POCKET	B	2'-6"	8'-11"	1 3/4"	12"	WOOD	WOOD	
120.1	MEGA FAMILY	120	SWING	A	3'-0"	8'-11"	1 3/4"	12"	WOOD	WOOD	
121.1	POOL BATH	121	POCKET	B	2'-6"	8'-11"	1 3/4"	12"	WOOD	WOOD	
122.1	POOL BATH	121	POCKET	B	2'-6"	8'-11"	1 3/4"	12"	WOOD	WOOD	
UPPER LEVEL											
201.1	HALL	203	SWING	A	2'-6"	8'-0"	1 3/4"	12"	WOOD	WOOD	
204.1	KIDS BATH	204	SWING	A	2'-6"	8'-0"	1 3/4"	12"	WOOD	WOOD	
205.1	KIDS ROOM	205	SWING	A	2'-6"	8'-0"	1 3/4"	12"	WOOD	WOOD	
210.1	OFFICE	210	SWING	A	2'-6"	8'-0"	1 3/4"	12"	WOOD	WOOD	
211.1	GUEST SUITE	211	SWING	A	2'-6"	8'-0"	1 3/4"	12"	WOOD	WOOD	
212.1	GUEST SUITE BATH	212	SWING	A	2'-6"	8'-0"	1 3/4"	12"	WOOD	WOOD	
213.1	GUEST	213	SWING	A	2'-6"	8'-0"	1 3/4"	12"	WOOD	WOOD	
214.1	GUEST BATH	214	SWING	A	2'-6"	8'-0"	1 3/4"	12"	WOOD	WOOD	

EXTERIOR DOOR SCHEDULE											
REF.	LOCATION	ROOM NUMBER	OPERATION	TYPE	DIMENSIONS			UNDERCUT	FINISH	FRAME	REMARKS
					WIDTH	HEIGHT	THICKNESS				
LOWER LEVEL											
007.1	OUTDOOR TOOL/FURNITURE STORAGE	007	SWING	C	4'-0"	8'-11"	1 3/4"	12"	FIBERGLASS	HMF	
MAIN LEVEL											
104.1	GARAGE	104	OVERHEAD	T	32'-0"	8'-0"	1 3/4"	0"	METAL	METAL	
111.1	HALL	111	SWING	C	3'-0"	8'-0"	1 3/4"	0"	FIBERGLASS	HMF	
UPPER LEVEL											
206.1	HALL	203	SWING	C	3'-0"	8'-0"	1 3/4"	12"			

EXTERIOR GLAZED DOOR SCHEDULE															
MARK	ORIENTATION	OPERATION	TYPE	DIMENSIONS (ROUGH OPENING)			U-VALUE	UA VALUE	GLASS TYPE	MANUFACTURER	SYSTEM	MODEL	SHGC	CFDF	REMARKS
				WIDTH	HEIGHT	AREA									
LOWER LEVELS															
009.2	WEST	SLIDING	E	14'-2"	9'-0"	127.5 SF	0.3	38.25	Clear Cardinal 272 - Argon - Clear Cardinal 89	FLEETWOOD	3070-T	OOX	0.34	FLE-M-88-00259-0001	
011.2	WEST	SLIDING	GO	8'-7"	9'-0"	77.25 SF	0.3	23.175	Clear Cardinal 272 - Argon - Clear Cardinal 89	FLEETWOOD	3070-T	OX	0.34	FLE-M-88-00259-0001	
011.3	SOUTH	SWING	C	3'-0"	9'-0"	27 SF	0.41	11.1	Clear Cardinal 272 - Argon - Clear Cardinal 89	FLEETWOOD	3900-T	H	0.23	FLE-M-103-00308-0001	
MAIN LEVEL															
100.1	NORTH	SWING	WI	4'-11 1/8"	9'-0"	44.34 SF	0.39	17.3	Clear Cardinal 272 - Argon - Clear Cardinal 89	FLEETWOOD	3900-T	HX	0.26	FLE-M-103-00308-0001	
107.1	NORTH	POCKET	D	4'-0"	9'-0"	36.75 SF	0.29	11.6	Clear Cardinal 272 - Argon - Clear Cardinal 89	FLEETWOOD	3070-T	PKV	0.34	FLE-M-88-00259-0001	
107.2	WEST	SLIDING	E	13'-4"	9'-0"	120 SF	0.29	34.8	Clear Cardinal 272 - Argon - Clear Cardinal 89	FLEETWOOD	3070-T	XOD	0.34	FLE-M-88-00259-0001	
108.1	EAST	POCKET	D	4'-4"	9'-0"	39 SF	0.29	11.3	Clear Cardinal 272 - Argon - Clear Cardinal 89	FLEETWOOD	3070-T	PKV	0.34	FLE-M-88-00259-0001	
108.2	WEST	SLIDING	E	21'-4"	9'-0"	193.86 SF	0.26	54	Clear Cardinal 272 - Argon - Clear Cardinal 89	FLEETWOOD	3070-T	XOXO	0.35	FLE-M-88-00259-0001	
108.3	EAST	POCKET	D	4'-4"	9'-0"	39 SF	0.29	11.3	Clear Cardinal 272 - Argon - Clear Cardinal 89	FLEETWOOD	3070-T	PKV	0.34	FLE-M-88-00259-0001	
108.4	EAST	SLIDING	E	12'-10"	9'-0"	115.86 SF	0.26	31.1	Clear Cardinal 272 - Argon - Clear Cardinal 89	FLEETWOOD	3070-T	OX	0.35	FLE-M-88-00259-0001	
118.4	WEST	SLIDING	E	12'-9"	9'-0"	114.75 SF	0.3	34.2	Clear Cardinal 272 - Argon - Clear Cardinal 89	FLEETWOOD	3070-T	OX	0.34	FLE-M-88-00259-0001	
120.2	WEST	SLIDING	GO	8'-0"	9'-0"	72 SF	0.31	22.3	Clear Cardinal 272 - Argon - Clear Cardinal 89	FLEETWOOD	3070-T	OX	0.33	FLE-M-88-00259-0001	
124.1	WEST	SWING	C	3'-8 1/2"	9'-0"	33.37 SF	0.41	13.7	Clear Cardinal 272 - Argon - Clear Cardinal 89	FLEETWOOD	3900-T	H	0.23	FLE-M-103-00308-0001	
UPPER LEVEL															
209.1	SOUTH	SWING	C	3'-0"	8'-0"	25.5 SF	0.41	10.2	Clear Cardinal 272 - Argon - Clear Cardinal 89	FLEETWOOD	3900-T	H	0.23	FLE-M-103-00308-0001	
Grand Total															
						1,069.19 SF		344.225							

WINDOW SCHEDULE															
MARK	ORIENTATION	OPERATION	DIMENSIONS (ROUGH OPENING)			U-VALUE	UA VALUE	GLASS TYPE	MANUFACTURER	SYSTEM	MODEL	SHGC	CFDF	REMARKS	
			WIDTH	HEIGHT	AREA										
1															
	NORTH	FIXED DOOR	7'-9 1/2"	8'-0"	70.13 SF	0.30	20.3	Clear Cardinal 272 - Argon - Clear Cardinal 89	FLEETWOOD	3800-T	OOVO-GTF	0.39	FLE-M-89-00452-0001		
2															
	WEST	FIXED HOPPER	6'-6"	8'-7 1/2"	59.31 SF	0.22	16.8	Clear Cardinal 272 - Argon - Clear Cardinal 89	FLEETWOOD	450-T	OH/OO-GTF	0.41	FLE-M-113-00044-0001		
3															
	SOUTH	FIXED AWNING	9'-0"	9'-7 1/2"	82.31 SF	0.22	17.8	Clear Cardinal 272 - Argon - Clear Cardinal 89	FLEETWOOD	450-T	OOA-GTF	0.41	FLE-M-113-00044-0001		
4															
	SOUTH	FIXED HOPPER	7'-6"	9'-1 1/2"	68.44 SF	0.22	14.9	Clear Cardinal 272 - Argon - Clear Cardinal 89	FLEETWOOD	450-T	OOVO-GTF	0.41	FLE-M-113-00044-0001		
5															
	SOUTH	FIXED AWNING	3'-0"	9'-1 1/2"	27.38 SF	0.24	6.5	Clear Cardinal 272 - Argon - Clear Cardinal 89	FLEETWOOD	450-T	OIA-GTF	0.39	FLE-M-113-00044-0001		
6A															
	SOUTH	FIXED	7'-9"	9'-0"	69.75 SF	0.26	18.1	Clear Cardinal 272 - Argon - Clear Cardinal 89	FLEETWOOD	3800-T	OO-GTF	0.39	FLE-M-89-00452-0001		
6B															
	SOUTH	FIXED	7'-9"	9'-0"	69.75 SF	0.26	18.1	Clear Cardinal 272 - Argon - Clear Cardinal 89	FLEETWOOD	3800-T	OO-GTF	0.39	FLE-M-89-00452-0001		
7															
	SOUTH	FIXED CASEMENT EGRESS	6'-0"	8'-7 1/2"	51.75 SF	0.25	12.8	Clear Cardinal 272 - Argon - Clear Cardinal 89	FLEETWOOD	450-T	OO/OO	0.35	FLE-M-111-00044-0001	WINDOW LIMITER TO COMPLY WITH ASTM F2090-17 FOR EGRESS	
8															
	EAST	FIXED AWNING	2'-4"	8'-7 1/2"	20.13 SF	0.24	4.7	Clear Cardinal 272 - Argon - Clear Cardinal 89	FLEETWOOD	450-T	OIA-GTF	0.39	FLE-M-113-00044-0001		
9															
	NORTH	FIXED HOPPER	7'-9 1/2"	8'-6"	66.23 SF	0.22	14.6	Clear Cardinal 272 - Argon - Clear Cardinal 89	FLEETWOOD	450-T	OH/OO-GTF	0.41	FLE-M-113-00044-0001		
10															
	EAST	FIXED	11'-8 1/2"	4'-6"	7.68 SF	0.24	1.8	Clear Cardinal 272 - Argon - Clear Cardinal 89	FLEETWOOD	450-T	O	0.39	FLE-M-113-00044-0001		
11															
	NORTH	FIXED CASEMENT EGRESS	7'-6"	8'-1 1/2"	60.94 SF	0.24	14.4	Clear Cardinal 272 - Argon - Clear Cardinal 89	FLEETWOOD	450-T	OO/OO	0.35	FLE-M-111-00044-0001	WINDOW LIMITER TO COMPLY WITH ASTM F2090-17 FOR EGRESS	
12															
	WEST	FIXED	16'-0"	8'-1 1/2"	130 SF	0.26	41.8	Clear Cardinal 272 - Argon - Clear Cardinal 89	FLEETWOOD	3800-T	OO/OO/OO/OO	0.38	FLE-M-89-00452-0001		
13															
	WEST	FIXED CASEMENT EGRESS	11'-0"	8'-1 1/2"	89.38 SF	0.23	20.2	Clear Cardinal 272 - Argon - Clear Cardinal 89	FLEETWOOD	450-T	OO/OO/OO	0.36	FLE-M-111-00044-0001	WINDOW LIMITER TO COMPLY WITH ASTM F2090-17 FOR EGRESS	
14															
	NORTH	FIXED CASEMENT EGRESS	4'-2"	8'-1 1/2"	33.85 SF	0.23	7.7	Clear Cardinal 272 - Argon - Clear Cardinal 89	FLEETWOOD	450-T	OO/G-GTF	0.40	FLE-M-113-00044-0001	WINDOW LIMITER TO COMPLY WITH ASTM F2090-17 FOR EGRESS	
15															
	WEST	FIXED	13'-3 1/2"	8'-1 1/2"	107.99 SF	0.22	23.5	Clear Cardinal 272 - Argon - Clear Cardinal 89	FLEETWOOD	450-T	OO/OO/OO	0.41	FLE-M-113-00044-0001		
Grand Total															
					1,010.95 SF		287.1								

DOOR SCHEDULE NOTES

- FIELD VERIFY ALL ROUGH OPENINGS BEFORE ORDERING DOORS
- EXTERIOR DOOR SIZE ARE DOOR PANEL SIZES U,N,O
- INTERIOR DOOR SIZE ARE DOOR PANEL SIZES U,N,O
- POCKET/SWING DOORS TO BE 2" LARGER THAN OPENING SIZE INDICATED TO ACCOMMODATE POCKET HEAD AND JAMB U,N,O
- ALL DOORS TO BE SOLID CORE OR FIRE RATED
- ALL SAFETY GLAZED SWINER DOORS EXCLUDED FROM SCHEDULE SEE INTERIOR ELEVATIONS FOR SIZES
- PROVIDE CLEARANCES AS NECESSARY AT HEAD AND FLOOR CONDITIONS
- ALL EXTERIOR DOORS TO HEATED SPACES TO BE INSULATED PER MUNICIPALITY REQUIREMENTS

WINDOW SCHEDULE NOTES

- ALL WINDOW DIMENSIONS REPRESENT PANEL SIZE. CONTRACTOR TO FIELD VERIFY
- ALL ROUGH OPENING DIMENSIONS PRIOR TO ORDERING WINDOWS AND DOORS
- PROVIDE EGRESS WINDOWS WHERE REQUIRED BY CODE
- INSET SCREENS AT ALL OPERABLE WINDOWS

193 Booth, Jackson St., Suite 2000
 Seattle, Washington 98104 USA
 T: (206) 451-2222
 F: (206) 451-2222
 E: info@olsonkundig.com

Olson Kundig

PROJECT:
FUSED ELEMENTS
 4525 FOREST AVE SE MERCER ISLAND WA 98040

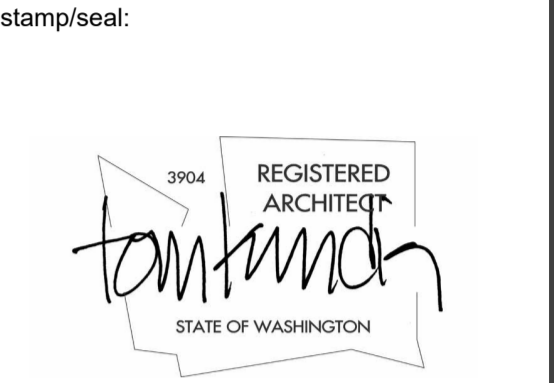

ENERGY CODE COMPLIANCE VIA PRESCRIPTIVE OPTION:
 REFER TO ENERGY CODE COMPLIANCE ON A/E/O FOR BUILDING REQUIREMENTS.
 VERTICAL FENESTRATION U=0.30
 TOTAL UA = 344.225 + 257.1 = 601.325
 TOTAL AREA = 1,138 SF + 999.81 SF = 2,138.81 SF
 TOTAL UA/AREA = 601.325 / 2,138.81 = 0.28 AREA WEIGHTED U VALUE < 0.30

WEIGHTED AVERAGE

	U-FACTOR	SHGC
GLAZED DOOR WEIGHT	0.30	0.337
GLAZED WINDOW WEIGHT	0.24	0.39
TOTAL AVERAGE WEIGHT	0.27	0.36

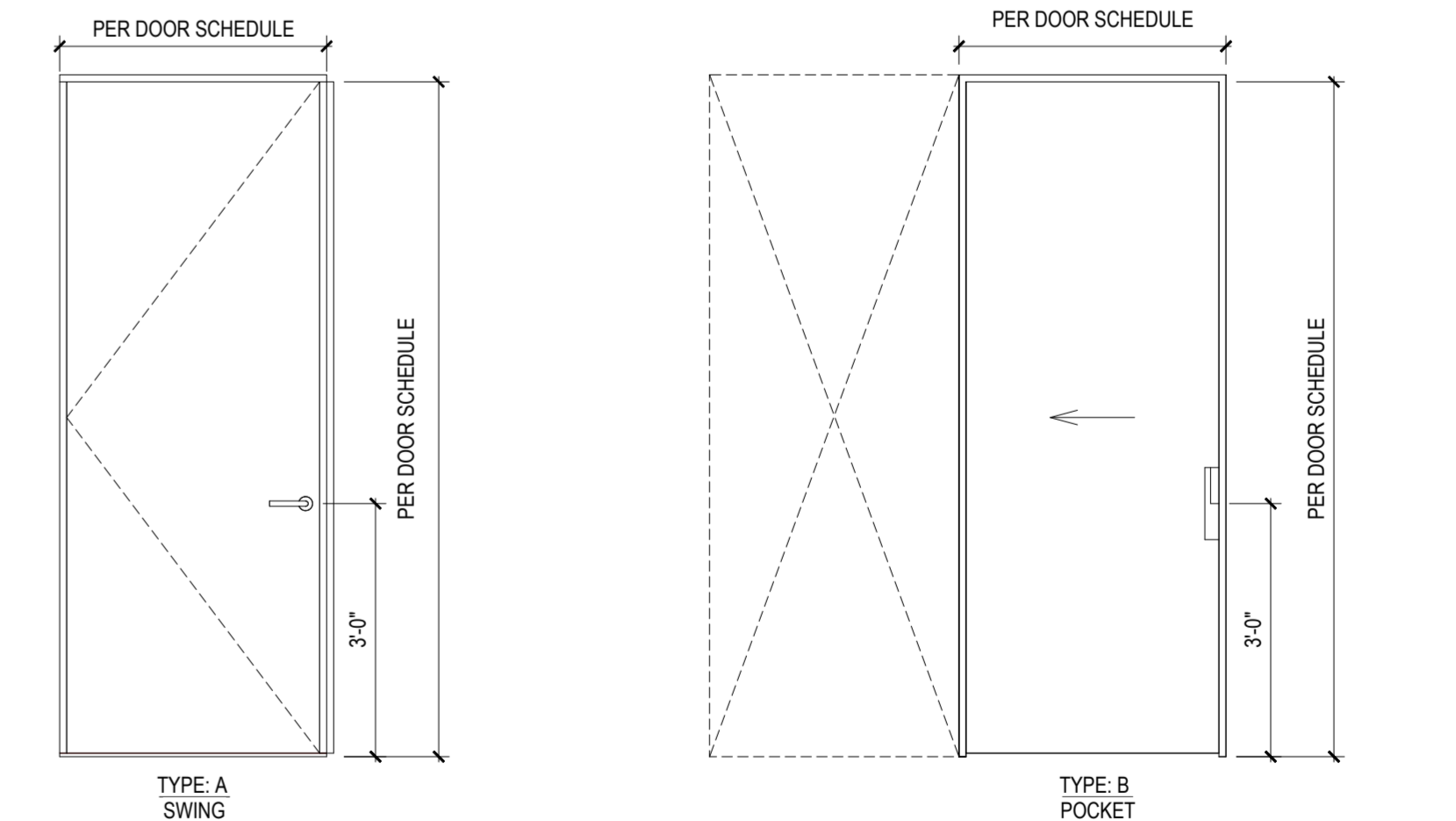

DOOR TYPES - INTERIOR
 SCALE: 1/2" = 1'-0"

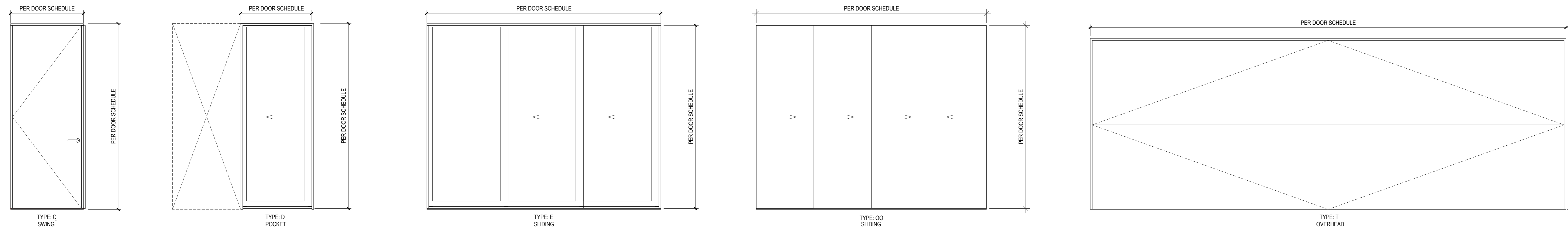

DOOR TYPES - EXTERIOR
 SCALE: 1/2" = 1'-0"

project architect: _____
 project manager: _____
 drawn by: _____
 checked by: _____<

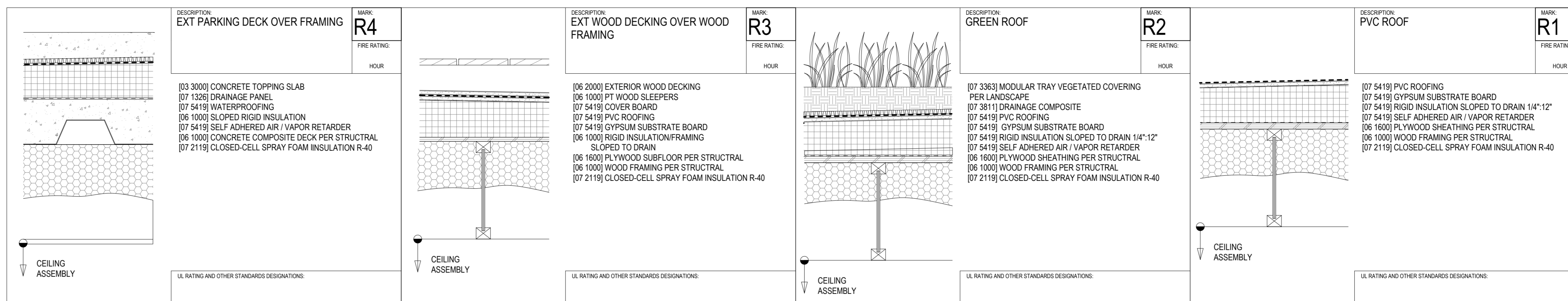

ROOF ASSEMBLIES
SCALE: 1 1/2" = 1'-0"

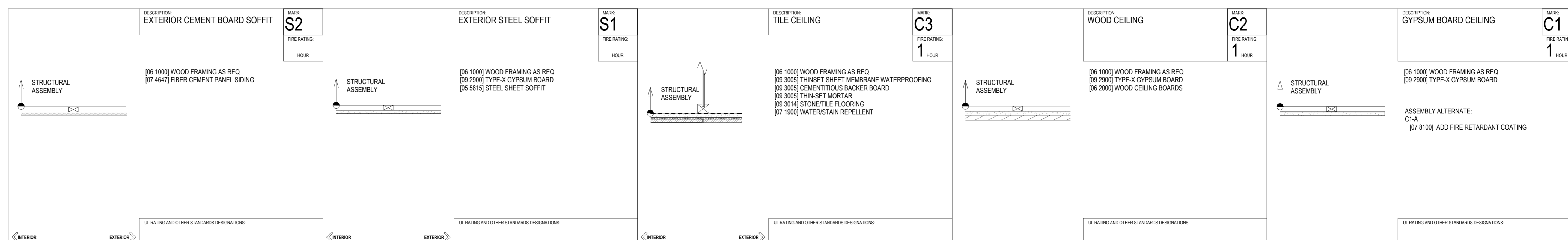

CEILING & SOFFIT ASSEMBLIES
SCALE: 1 1/2" = 1'-0"

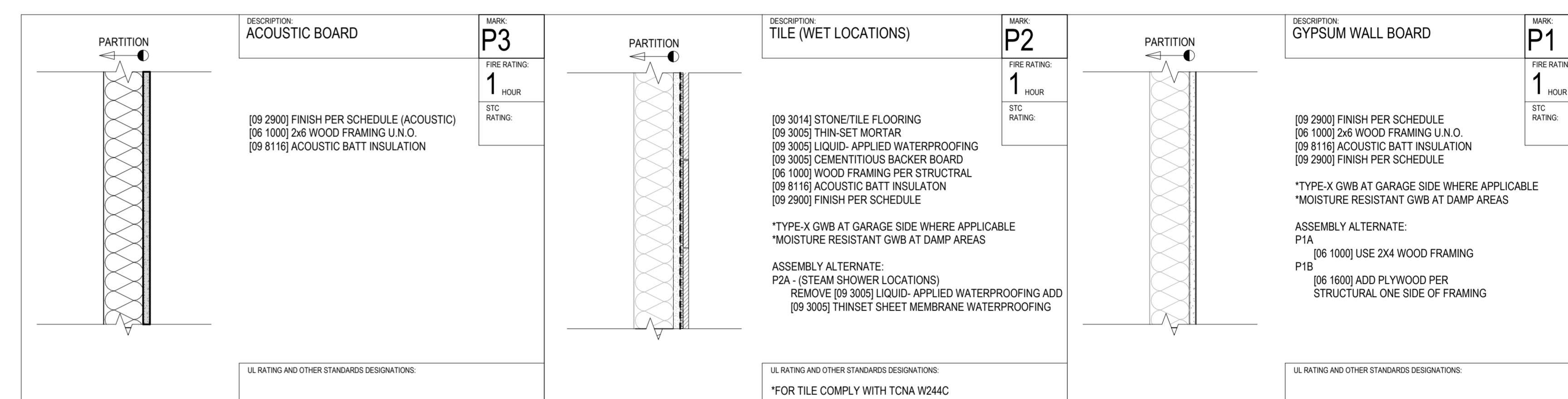

INTERIOR WALL ASSEMBLIES
SCALE: 1 1/2" = 1'-0"

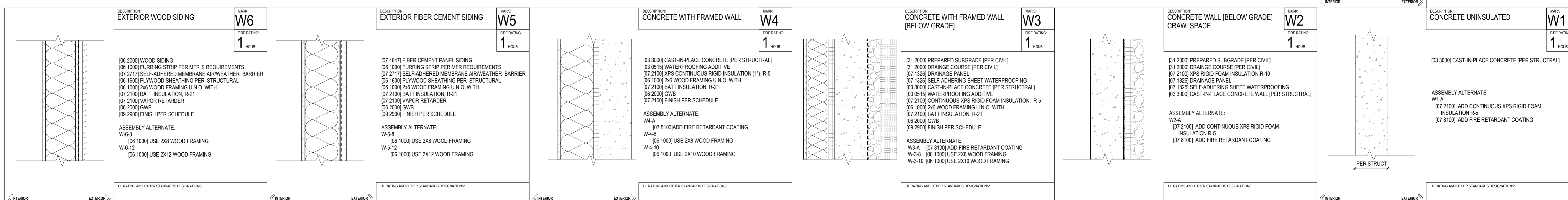

EXTERIOR WALL ASSEMBLIES
SCALE: 1 1/2" = 1'-0"

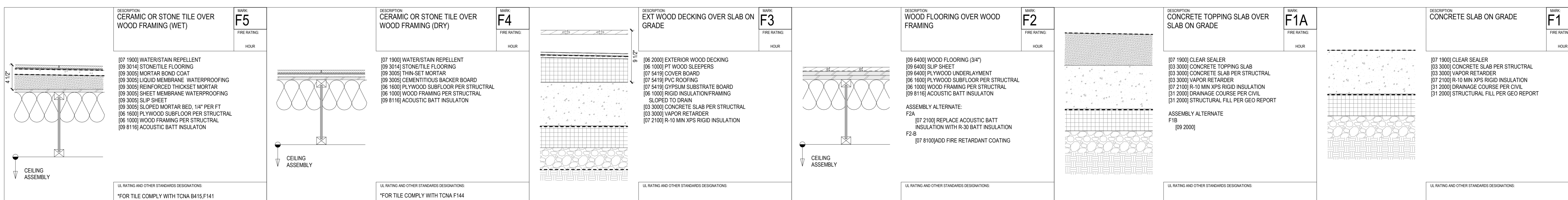

FLOOR ASSEMBLIES
SCALE: 1 1/2" = 1'-0"

Olson Kundig
 PROJECT: FUSED ELEMENTS
 4525 FOREST AVE SE MERCER ISLAND, WA 98040

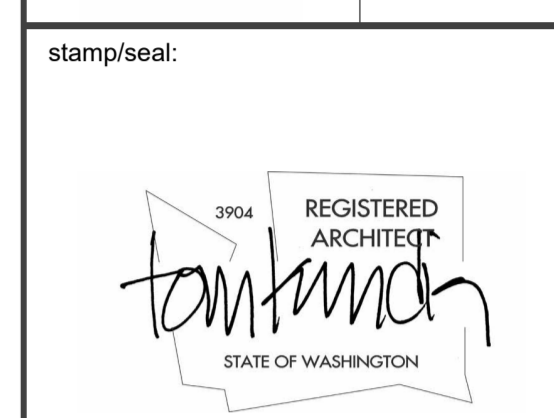

project architect: _____
 project manager: _____
 drawn by: _____
 checked by: _____
 job no.: _____
 revisions: _____
 no.: _____ date: _____ description: _____

PERMIT SET
 09/08/2023

ASSEMBLIES

A0.30

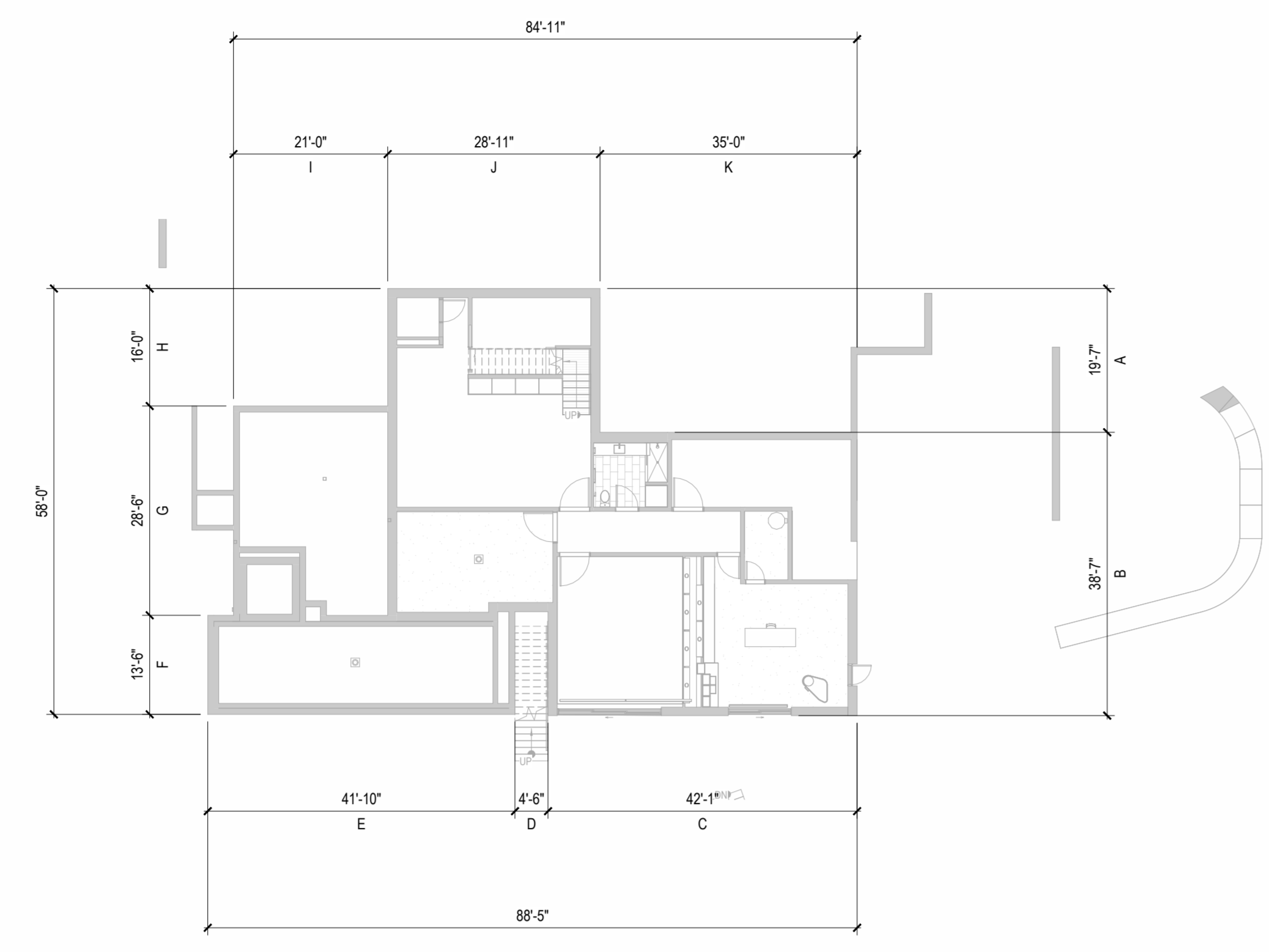

2A BASEMENT FLOOR AREA CALCULATION PER MICC
 SCALE: 1/16" = 1'-0"

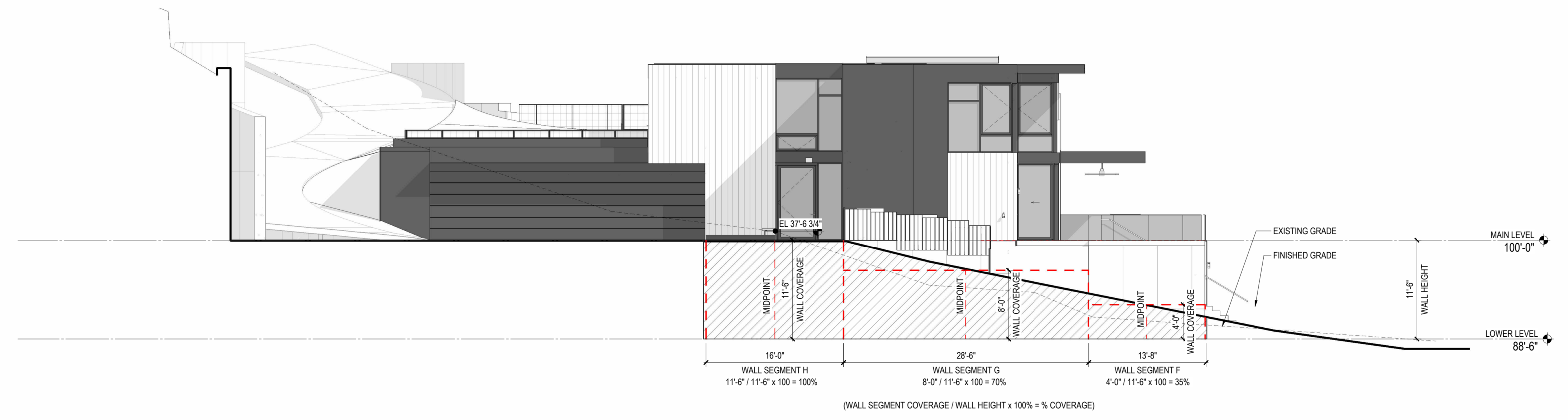

2B BASEMENT FLOOR AREA WALL SEGMENT COVERAGE-NORTH ELEVATION
 SCALE: 1/8" = 1'-0"

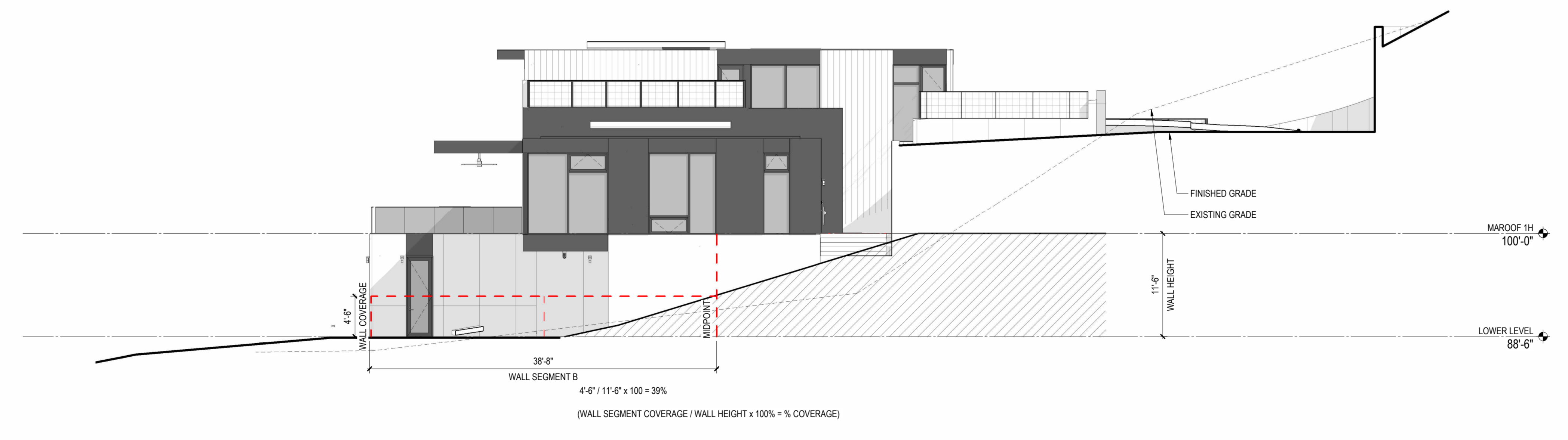

2C BASEMENT FLOOR AREA WALL SEGMENT COVERAGE-SOUTH ELEVATION
 SCALE: 1/8" = 1'-0"

WALL SEGMENT	LENGTH x	COVERAGE =	RESULT
A	19'-7"	100%	19'-7"
B	38'-5"	0	0
C	42'-11"	0	0
D	4'-6"	0	0
E	41'-10"	0	0
F	13'-6"	35%	4'-8"
G	28'-6"	70%	19'-11"
H	16'-0"	100%	16'-0"
I	21'-0"	100%	21'-0"
J	28'-11"	100%	28'-11"
K	35'-0"	100%	35'
TOTAL	297'-2"	N/A	145'-4"

PORTION OF EXCLUDED FLOOR AREA (145'-4" / 297'-2") x 100% = 50%
 (SUM OF RESULTS) / (SUM OF LENGTHS) = %
 TOTAL GROSS FLOOR AREA SUBTRACTED: 3,240 SF x 50% = 1,620 SF
TOTAL BASEMENT GROSS FLOOR AREA PER MICC CALC: 3,240 SF - 1,620 SF = 1,620 SF
 (REFERENCE MICC UNIFIED LAND DEVELOPMENT APPENDIX B)

2D BASEMENT FLOOR AREA CALC PER MICC
 SCALE: 1/2" = 1'-0"

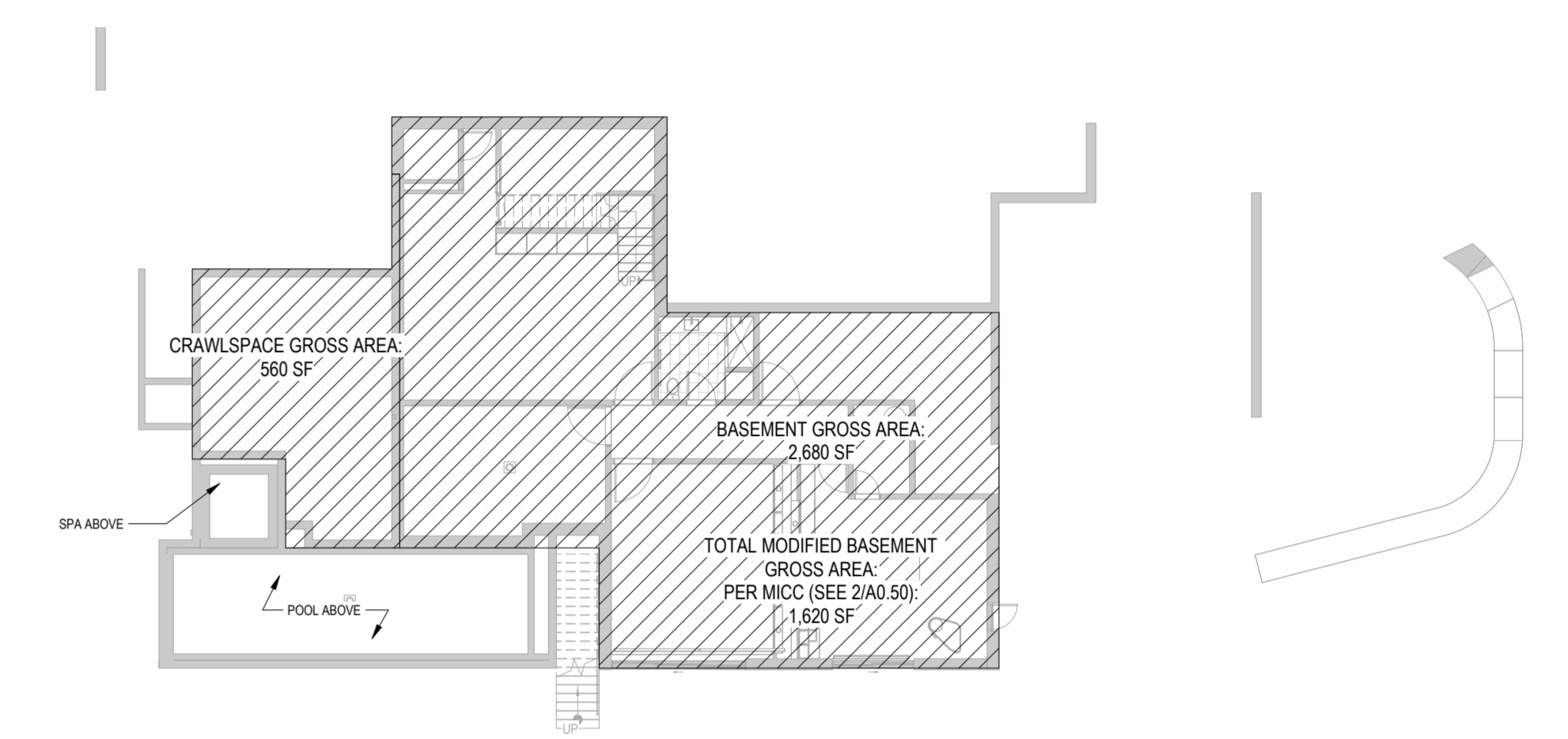

1A BASEMENT LEVEL GROSS SF - 1,620 SF
 SCALE: 1/16" = 1'-0"

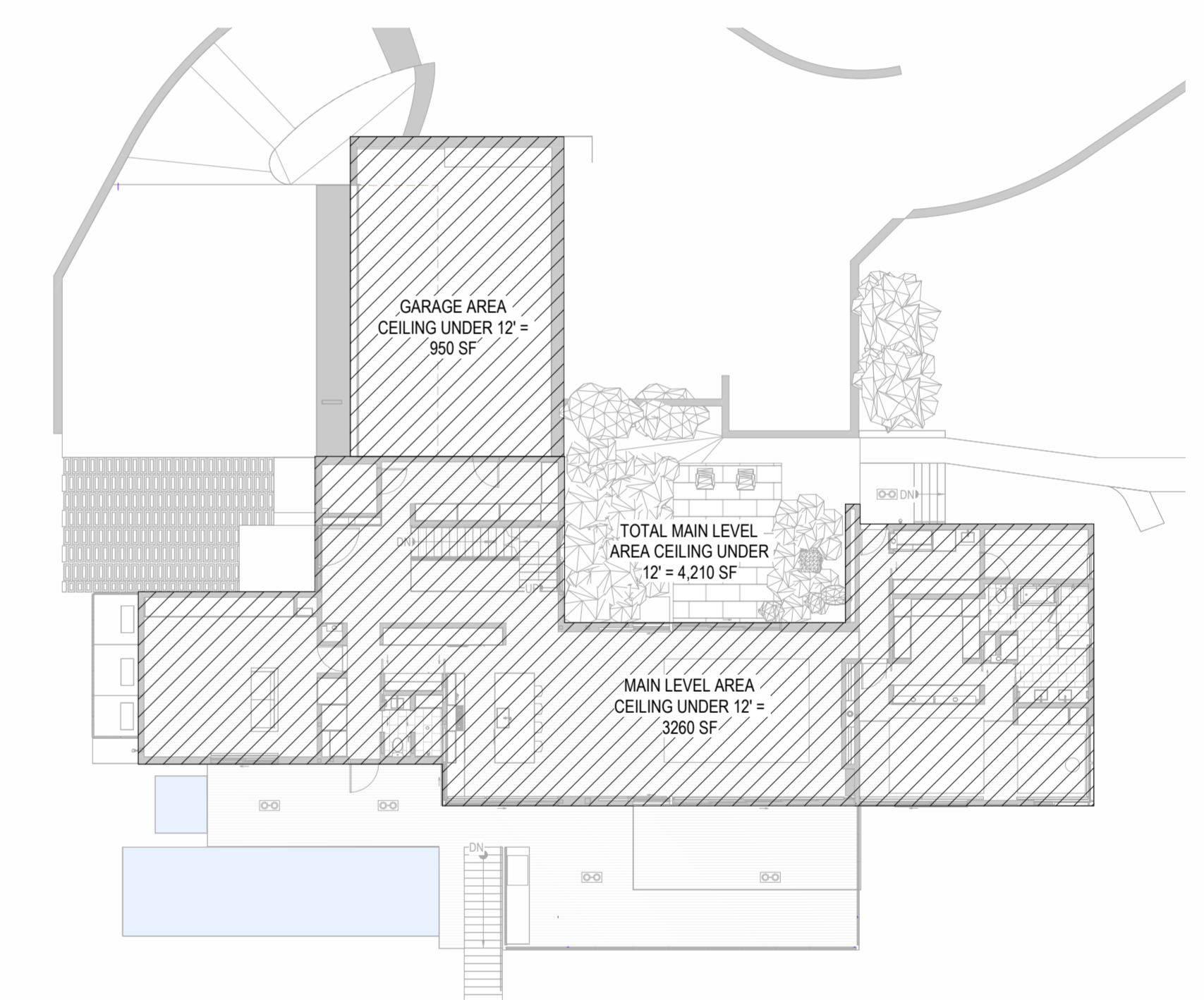

1B MAIN LEVEL GROSS SF - 4,210 SF
 SCALE: 1/16" = 1'-0"

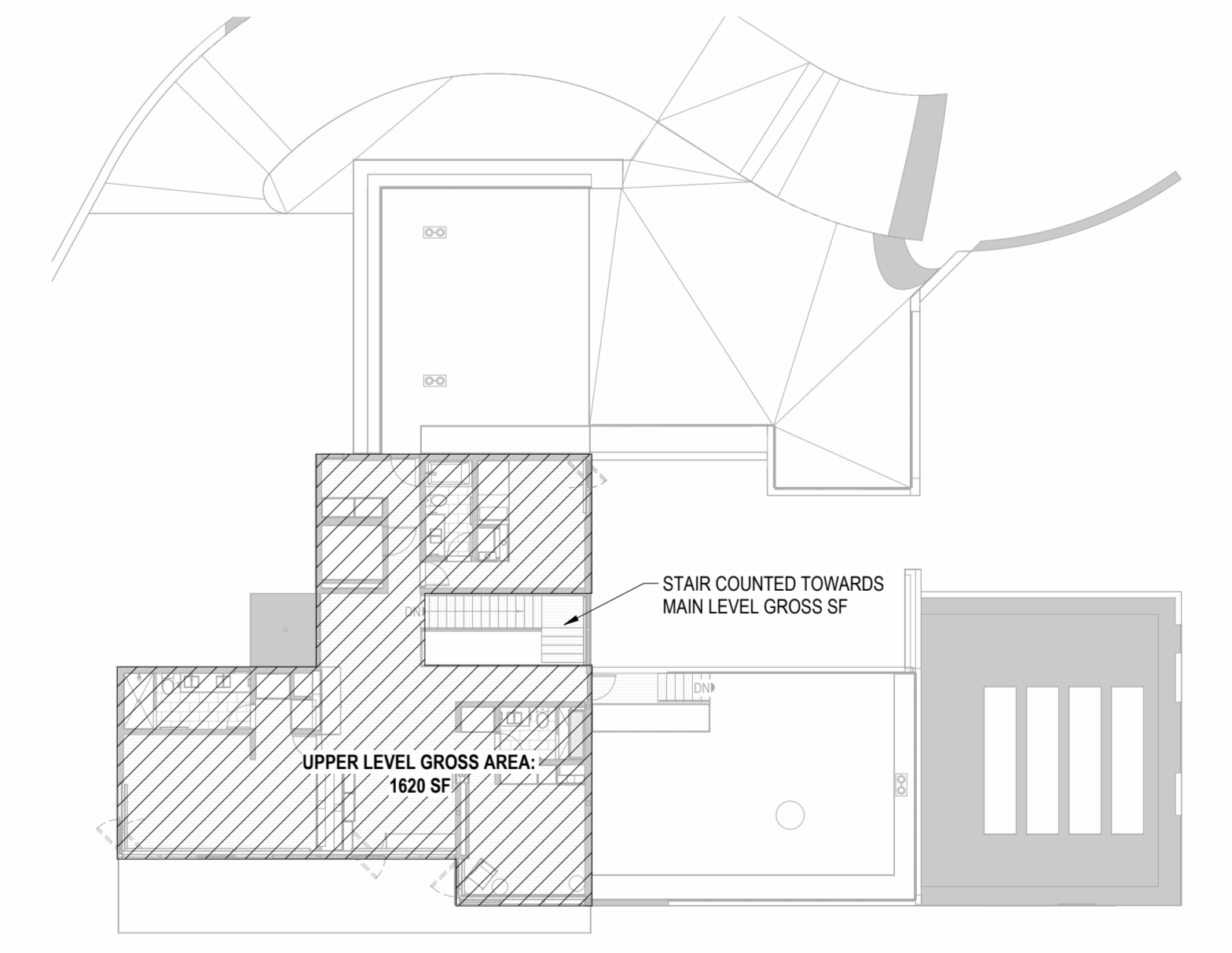

1C UPPER LEVEL GROSS SF - 1,620 SF
 SCALE: 1/16" = 1'-0"

BASEMENT TOTAL GROSS SF:	3,240 SF
BASEMENT AREA EXCLUDED PER MERCER ISLAND DEVELOPMENT CODE CALCULATION (SEE A1.50):	-1,620 SF
TOTAL GROSS AREA BASEMENT GROSS SF (MODIFIED):	1,620 SF
MAIN LEVEL CEILING UNDER 12':	4,205 SF
UPPER LEVEL:	1,620 SF
TOTAL:	7,445 SF
ALLOWABLE:	12,000 SF

TOTAL GROSS SF CALCULATION

project architect: _____
 project manager: _____
 drawn by: _____
 checked by: _____
 job no.: _____

revisions:

 no.: _____ date: _____ description: _____

PERMIT SET
 09/08/2023

ZONING - GROSS SQ FT CALCS

sheet:
A0.50

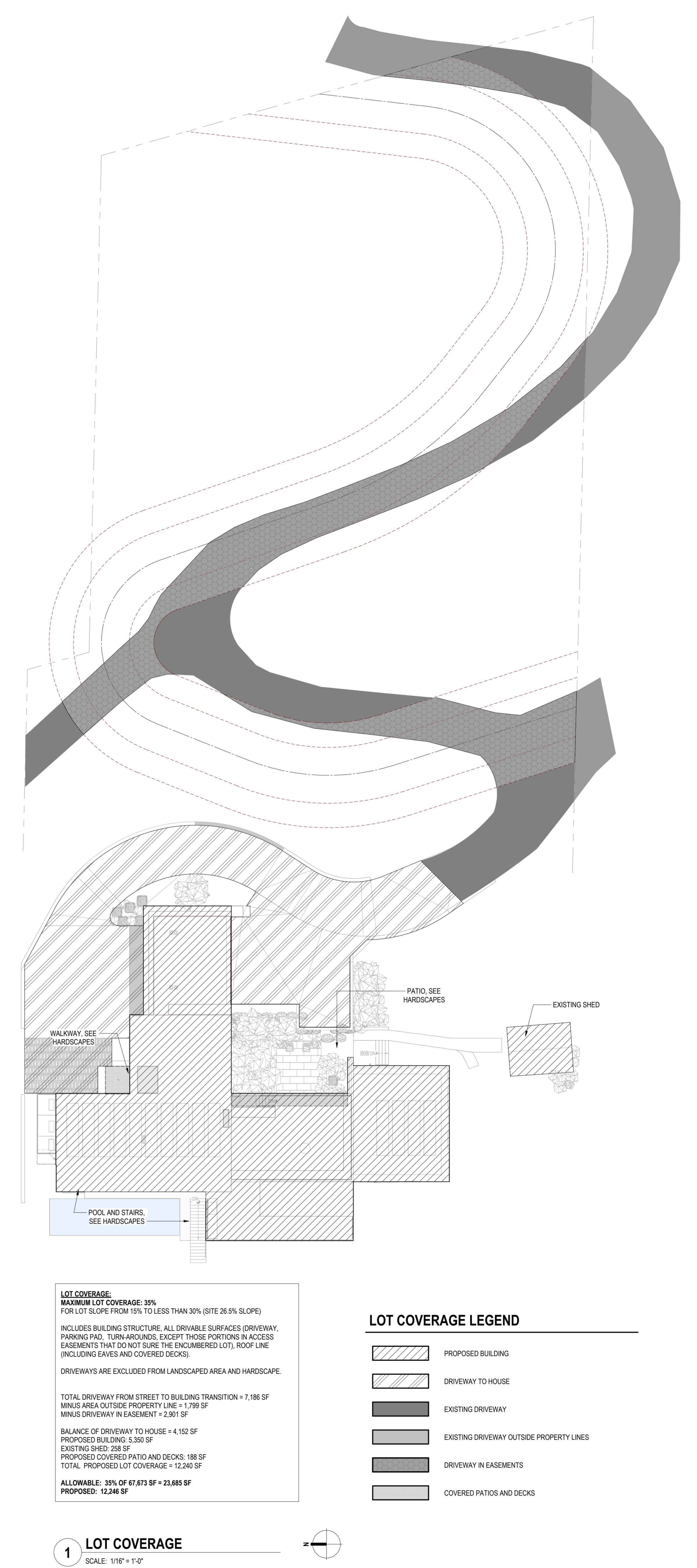
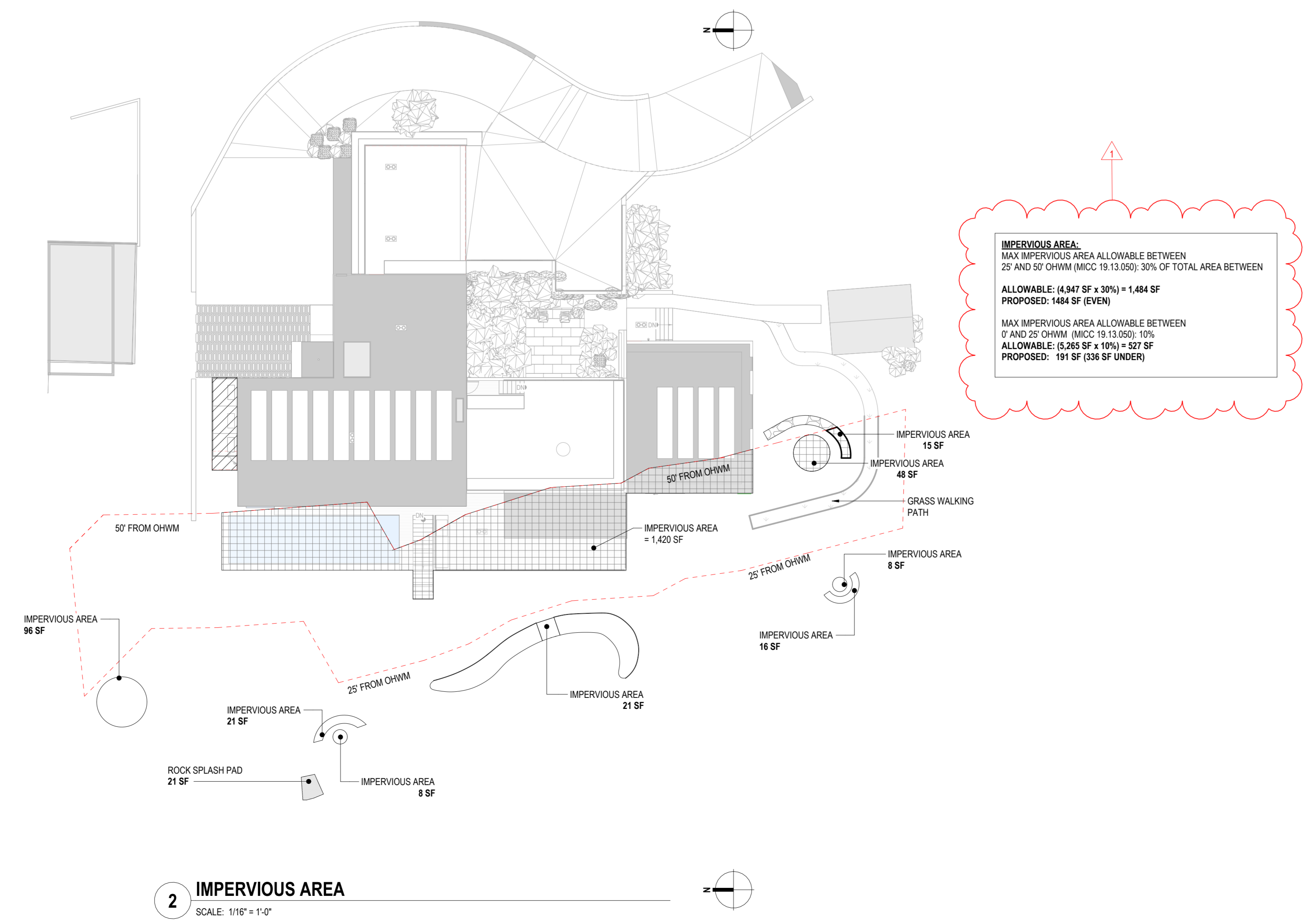
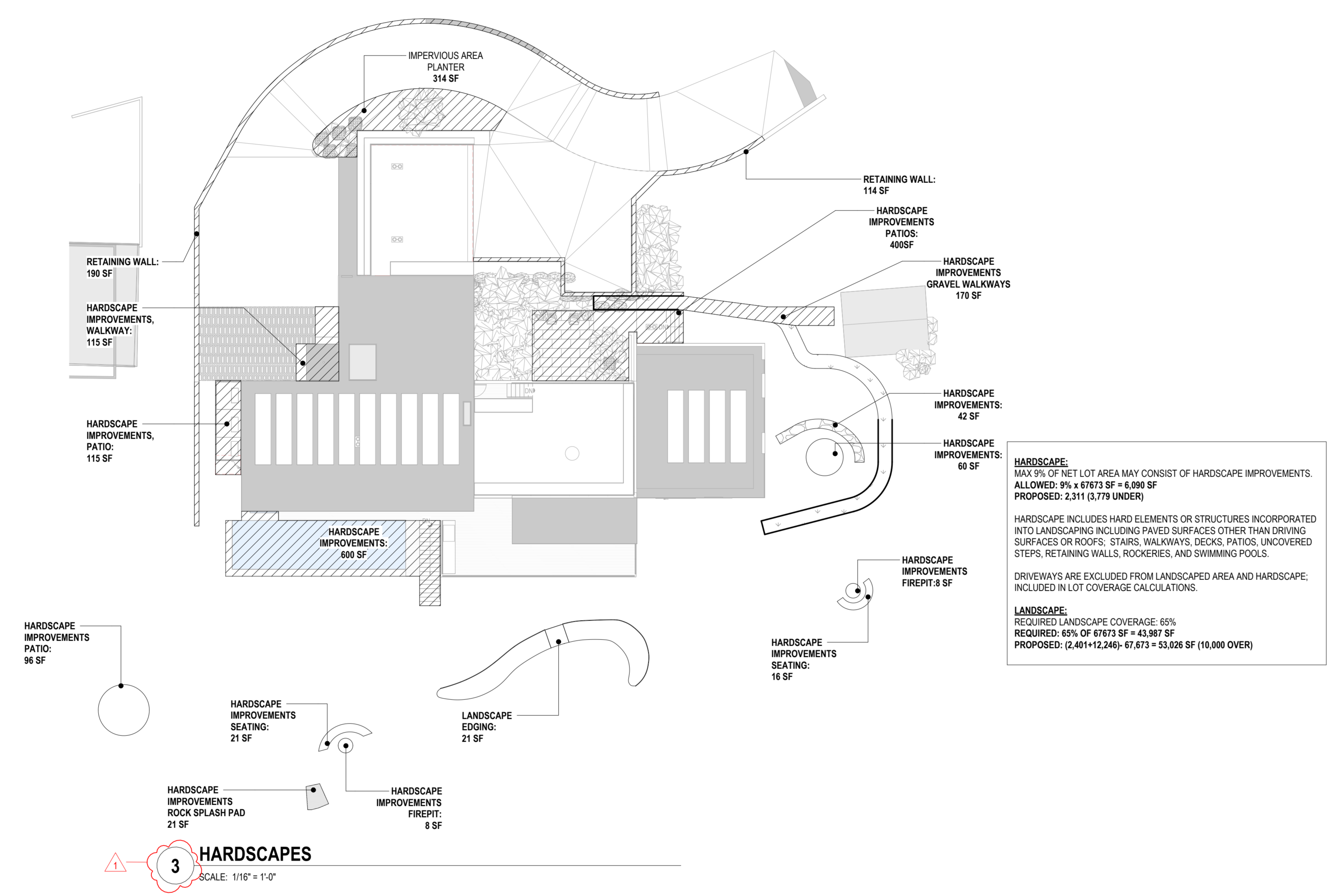

project architect:
project manager:
drawn by:
checked by:
job no.:

revisions:
1 02/23/24 R1 PERMIT
no. date description:

PERMIT SET
09/08/2023

950:
ZONING - AREAS & LOT COVERAGE

sheet:
A0.51

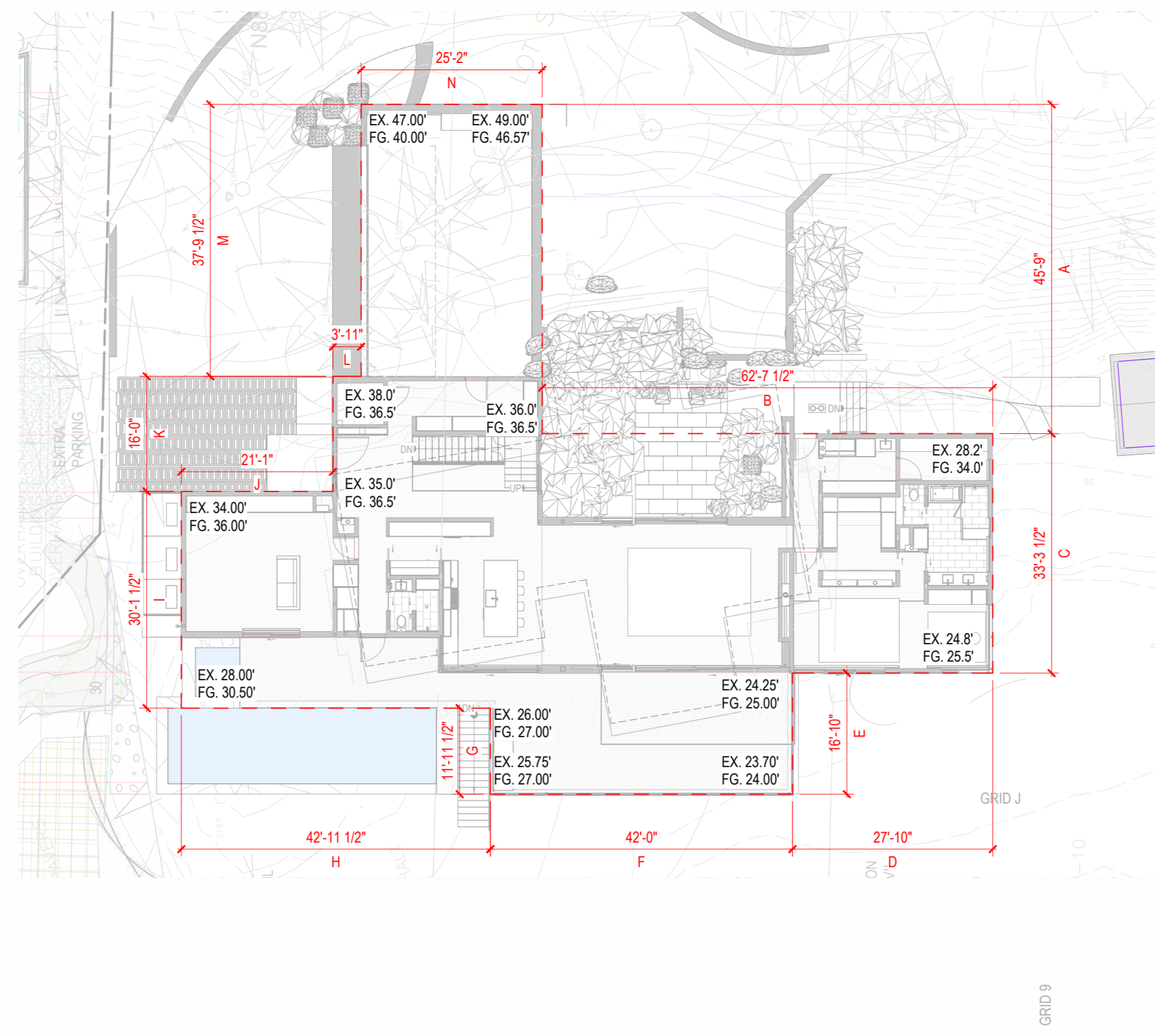

3A AVERAGE ELEVATION BUILDING ELEVATION - PLAN
SCALE: 1/16" = 1'-0"

AVERAGE BUILDING ELEVATION					
INDIVIDUAL WALL SEGMENT	LOWEST ELEVATION (FT)		WALL MID-POINT ELEVATION (FT)	WALL SEGMENT LENGTH (FT)	WEIGHTED SUM OF MID-POINT ELEV (FT) (MID POINT ELEV) x (LENGTH OF WALL SEGMENT)
	POINT 1	POINT 2	(POINT 1 + POINT 2)/2		
A	46.57	36	41.29	45.75	1888.8
B	32.5	28.2	30.35	62.58	839.8
C	28.2	36	26.5	33.29	882.2
D	24.8	24.75	24.525	27.8	681.8
E	24.25	23.7	23.975	16.83	403.5
F	23.7	25.75	24.725	42	1038.5
G	25.75	26	25.875	11.96	309.5
H	26	28	27	42.95	1159.7
I	28	34	31	30.13	934.0
J	34	35	34.5	21.1	727.95
K	35	36.5	35.75	16.00	572.0
L	36.5	36	36.25	3.92	142.1
M	36.5	40	38.25	37.79	1445.5
N	40	46.57	43.29	25.17	1089.5
TOTAL				417.27	12114.9
					29

AVERAGE BUILDING ELEVATION (FT) = (WEIGHTED SUM OF THE MIDPOINT ELEVATIONS) / (TOTAL LENGTH OF WALL SEGMENTS)

31.9' SURVEY ELEVATION = 92'-6" = AVERAGE BUILDING ELEVATION
92'-6" + 30' HEIGHT LIMIT = 122'-6" = MAX AVERAGE BUILDING HEIGHT LIMIT

3B AVERAGE BUILDING ELEVATION CALCS
SCALE: 1/2" = 1'-0"



2 WEST ELEVATION - DOWNHILL FACADE
SCALE: 1/8" = 1'-0"

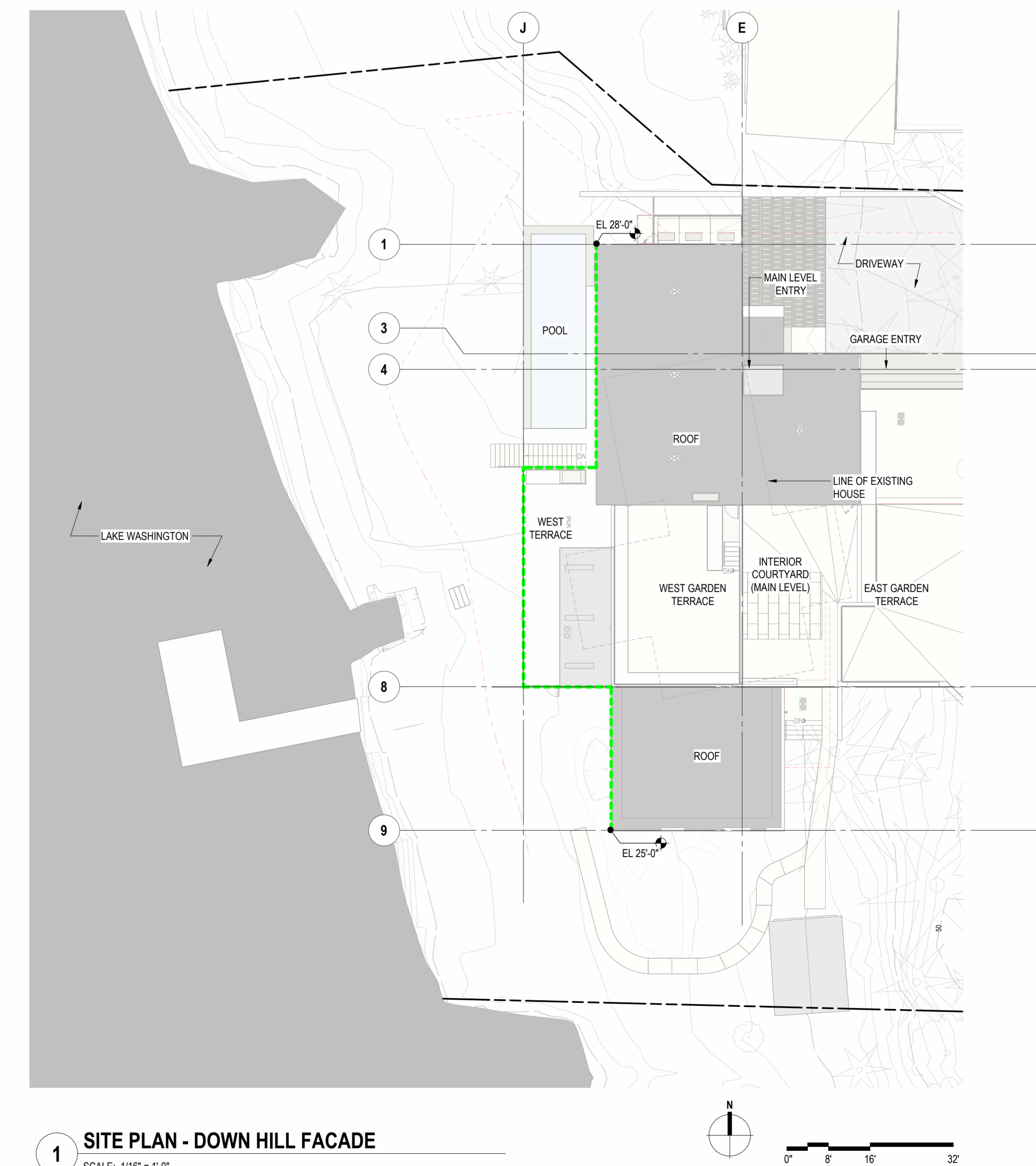

1 SITE PLAN - DOWN HILL FACADE
SCALE: 1/16" = 1'-0"



project architect: _____
project manager: _____
drawn by: _____
checked by: _____
job no.: _____

revisions:

1 02/23/24 R1 PERMIT
no. date description:

PERMIT SET
09/08/2023

ZONING - BUILDING HEIGHT

sheet: **A0.52**

stamp/real:



DRAWING LEGEND

- 102 ● TREE ID PER ARBORIST REPORT
- 101 ● EXCEPTIONAL TREE / ID PER ARBORIST REPORT
- DRIPLINE OF EXCEPTION TREE
- BUILDABLE AREA AROUND EXCEPTIONAL TREES

**RETENTION / REMOVAL OF EXCEPTIONAL TREES
(MICC 19.10.060(A)(3))**

B. RETENTION WILL LIMIT THE CONSTRUCTIBLE GROSS FLOOR AREA TO LESS THAN 85% OF THE MAXIMUM GROSS FLOOR AREA ALLOWED UNDER MICC 19.02

<p>6,651 SF BUILDABLE AREA AROUND EXCEPTIONAL TREES (EXCLUDING SE PART OF SITE)</p> <p>12,000 SF MAX ALLOWABLE SF PER MICC 85% x 12,000 SF = 10,200 SF</p> <p>10,200 SF ALLOWABLE - 6,651 SF BUILDABLE AREA AROUND EXCEPTIONAL TREES 3,549 SF DEFICIT</p>	<p>ALTERNATE CALCULATION INCLUDING SE PART OF THE SITE</p> <p>9,419 SF BUILDABLE AREA AROUND EXCEPTIONAL TREES (INCLUDING SE PART OF SITE)</p> <p>10,200 SF ALLOWABLE - 9,419 SF BUILDABLE AREA AROUND EXCEPTIONAL TREES 781 SF DEFICIT</p>
---	--

MICC 19.07.180 WATERCOURSES

19.07.180.B.1. DEVELOPMENT WITHIN WATERCOURSES AND/OR BUFFERS IS PROHIBITED UNLESS ONE OF THE FOLLOWING CONDITIONS APPLIES:
(NOTE: NONE OF THESE APPLY TO THIS PROJECT, 4525 FOREST AVE SE)

- a. THE PROPOSED ACTIVITY IS SPECIFICALLY EXEMPT PURSUANT TO SECTION 19.07.130.
- b. A CRITICAL AREA REVIEW 1 APPLICATION IS REVIEWED AND APPROVED FOR ONE OF THE MODIFICATIONS IN SECTION 19.07.130; OR
- c. THE PROPOSED ACTIVITY IS PERMITTED UNDER SUBSECTION D OF THIS SECTION, DEVELOPMENT STANDARDS-ADDITIONAL CRITERIA FOR SPECIFIC ACTIVITIES.

19.07.180.C.7 BUILDINGS AND OTHER STRUCTURES SHALL BE SET BACK A MINIMUM OF TEN FEET FROM THE EDGES OF A WATERCOURSE BUFFER.

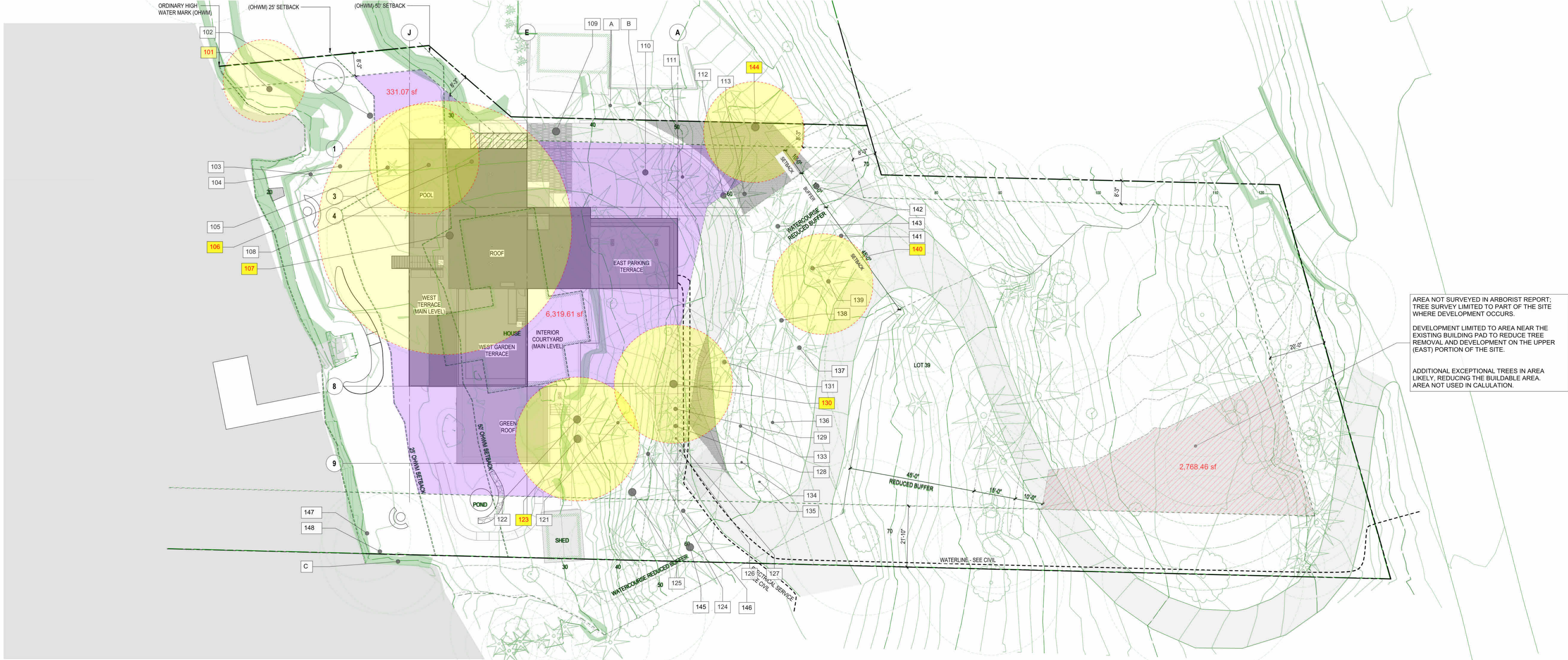

1 **EXCEPTIONAL TREE - BUILDABLE AREA EXHIBIT**
SCALE: 1/16" = 1'-0"

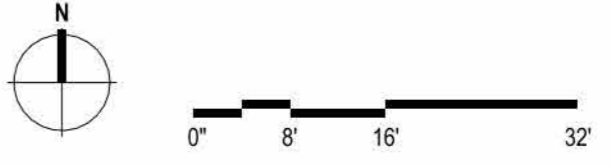

- project architect: _____
project manager: _____
drawn by: _____
checked by: _____
job no.: _____

revisions:

no.: _____ date: _____ description: _____

PERMIT SET
09/08/2023

950: **EXCEPTIONAL TREE-BUILDABLE AREA EXHIBIT**

sheet: **A0.53**

SITE PLAN NOTES

1. SITE SURVEY ELEVATION 36'-0" = MAIN LEVEL BUILDING ELEVATION 100'-0"
2. SEE CIVIL DRAWINGS FOR GRADING AND DRAINAGE PLANS
3. SEE ARBORIST REPORT FOR EXISTING TREE LOCATIONS
4. MCC 19.02.020 EACH SINGLE-FAMILY DWELLING WITH A GROSS FLOOR AREA OF 3,000 SQUARE FEET OR MORE SHALL HAVE AT LEAST THREE PARKING SPACES SUFFICIENT IN SIZE TO PARK A PASSENGER AUTOMOBILE. PROVIDED, AT LEAST TWO OF THE STALLS SHALL BE COVERED STALLS.
5. SEE SURVEY FOR ALL EASEMENTS
6. SEE CIVIL FOR ALL PROPOSED (P) WALL HEIGHTS. SEE SURVEYS FOR ALL EXISTING (E) WALLS
7. ALL WALLS GREATER THAN 3' IN HEIGHT THAT ARE ADJACENT TO WALKING SURFACES SHALL COMPLY WITH FALL PROTECTION CODE MINIMUMS
8. ASSOCIATED LAND USE APPLICATIONS INCLUDE CARZ AND SHORELINE EXEMPTION PERMIT
9. ADDRESS IDENTIFICATION LOCATED AT FOREST AVE NE TO COMPLY WITH SECTION R319.1

SITE PLAN LEGEND

- PROPERTY LINE
- - - SIDE SETBACK
- - - SETBACK EASEMENTS
- 10' EXISTING CONTOURS
- 2' EXISTING CONTOURS
- DRIVEWAY CENTERLINE
- BUILDING PAD

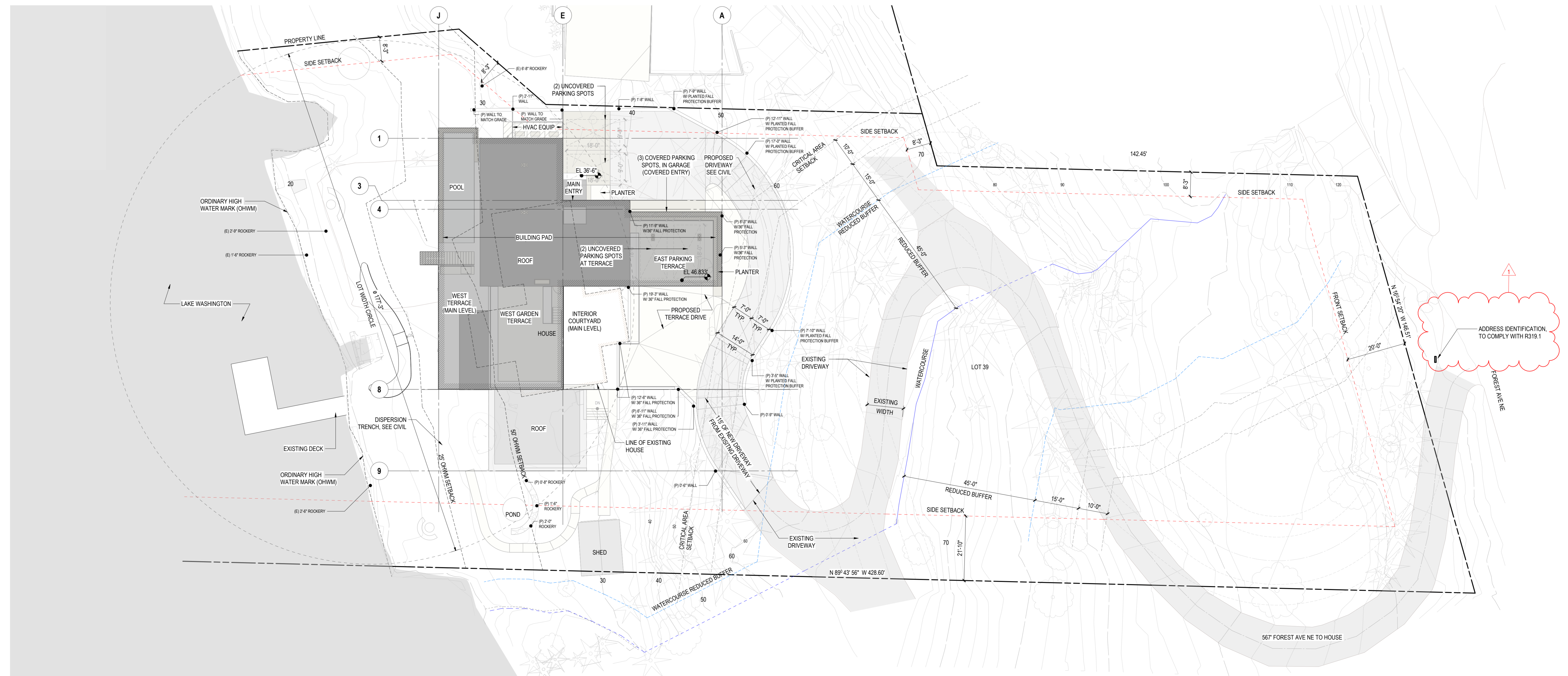

1515 South Jackson St. Suite 1000
 Seattle, Washington 98148 USA
 P: 206.451.8171
 www.olsonkundig.com

Olson Kundig

PROJECT:
FUSED ELEMENTS
 4525 FOREST AVE SE MERCER ISLAND, WA 98040

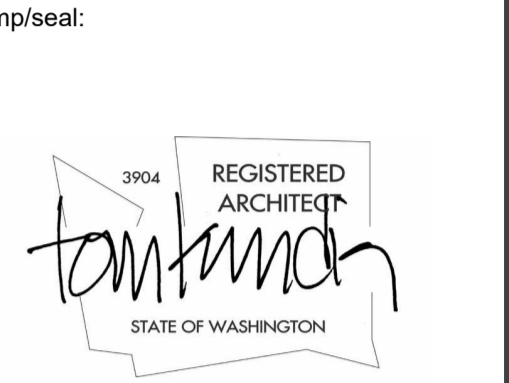

project architect: _____
 project manager: _____
 drawn by: _____
 checked by: _____
 job no.: _____

revisions:

1	02/23/24	R1 PERMIT
no.:	date:	description:

PERMIT SET
 09/08/2023

SITE PLAN

sheet:
A1.00

1 SITE PLAN
 SCALE: 1/16" = 1'-0"

- ### FLOOR PLAN NOTES
- BUILDING ELEVATION 100" ± USGS 36.5 FT
 - ALL INTERIOR WALLS TO BE 2x8 U.N.O.
 - ORIENTATION OF ELEVATIONS ARE GIVEN BY PROJECT NORTH
 - INTERIOR TO BE SPRINKLED WITH AN UPGRADED "NFPA 13R PLUS" SYSTEM
 - ALL INTERIOR WALLS TO INCLUDE ACOUSTIC BATT U.N.O.
 - FLOOR DRAINS AT MECHANICAL TO BE DESIGN BUILD
 - FLOOR SLOPE TO BE BASED ON DRAIN POSITION
 - ALL SPECIALTY OUTLETS, SWITCHES, AND MISC CONTROLS TO BE VERIFIED BY CLIENT
 - FIRE BLOCKING SHALL BE PROVIDED PER R02.11

- ### FLOOR PLAN LEGEND
- SMOKE/CM COMBO DETECTOR
 - OUTDOOR HEAT DETECTOR PER R314.2.3

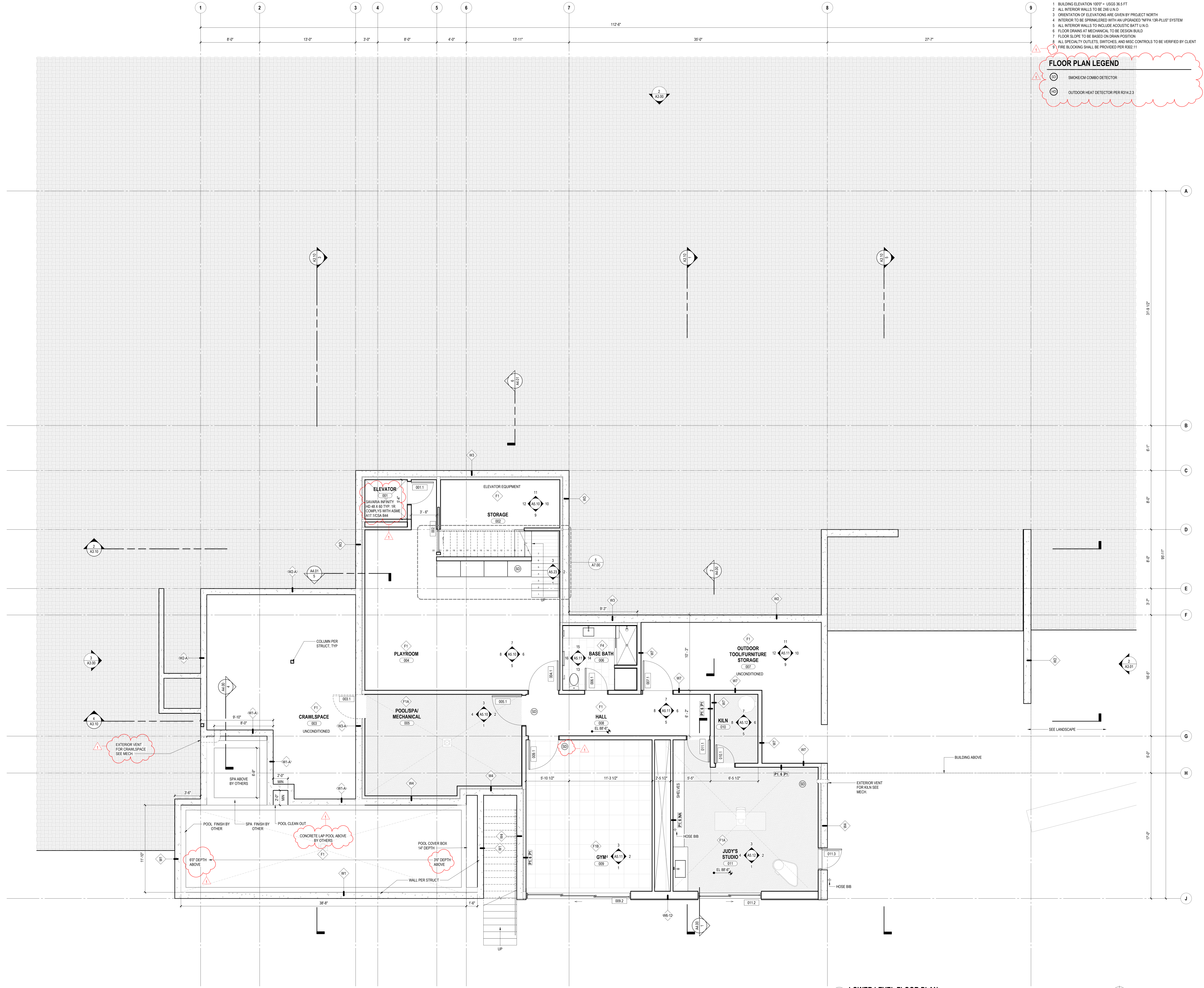

1 LOWER LEVEL FLOOR PLAN
SCALE: 1/4" = 1'-0"

Olson Kundig
 project:
FUSED ELEMENTS
 4525 FOREST AVE SE MERCER ISLAND, WA 98040

stamp/real:

 REGISTERED ARCHITECT
 STATE OF WASHINGTON

project architect:
 project manager:
 drawn by:
 checked by:
 job no.:

revisions:

1	02/23/24	R1 PERMIT
no.	date:	description:

PERMIT SET
09/08/2023

LOWER LEVEL FLOOR PLAN

sheet:
A2.10

- FLOOR PLAN NOTES**
- BUILDING ELEVATION 100'-0" USGS 36.5 FT
 - ALL INTERIOR WALLS TO BE 2x8 U.N.O.
 - ORIENTATION OF ELEVATIONS ARE GIVEN BY PROJECT NORTH
 - INTERIOR TO BE SPRINKLERED WITH AN UPGRADED "NFPA 13R PLUS" SYSTEM
 - ALL INTERIOR WALLS TO INCLUDE ACOUSTIC BATT U.N.O.
 - FLOOR DRAINS AT MECHANICAL TO BE DESIGN BUILD
 - FLOOR SLOPE TO BE BASED ON DRAIN POSITION
 - ALL SPECIALTY OUTLETS, SWITCHES, AND MISC CONTROLS TO BE VERIFIED BY CLIENT
 - FIRE BLOCKING SHALL BE PROVIDED PER R02.11

- FLOOR PLAN LEGEND**
- (SC) SMOKE/CO COMBO DETECTOR
 - (HD) OUTDOOR HEAT DETECTOR PER R314.2.3

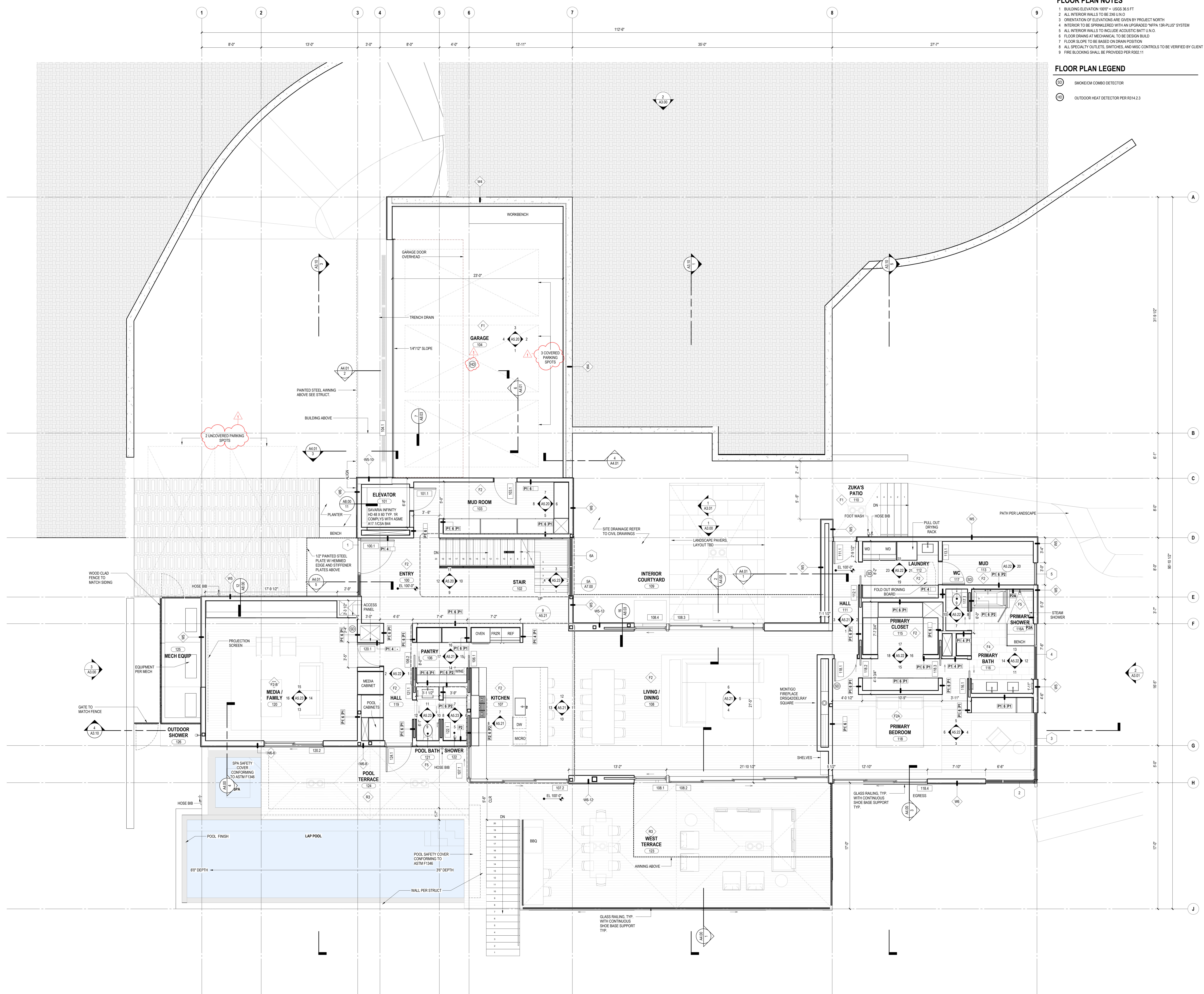

1 MAIN LEVEL FLOOR PLAN
SCALE: 1/4" = 1'-0"

Olson Kundig
PROJECT: FUSED ELEMENTS
4525 FOREST AVE SE MERCER ISLAND WA 98040

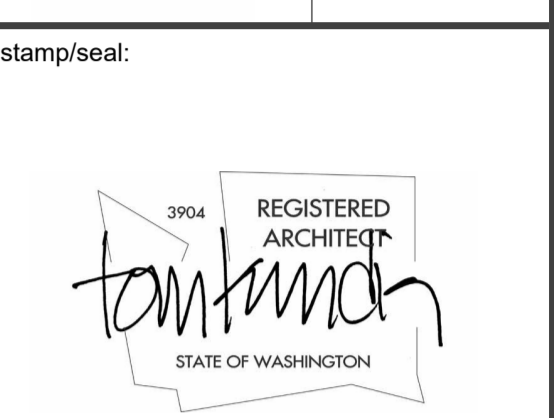

stamp/seal: REGISTERED ARCHITECT STATE OF WASHINGTON

project architect: _____
 project manager: _____
 drawn by: _____
 checked by: _____
 job no.: _____

revisions:

1	02/23/24	R1 PERMIT
no.	date:	description:

PERMIT SET
09/08/2023

950:

MAIN LEVEL FLOOR PLAN

sheet: **A2.20**

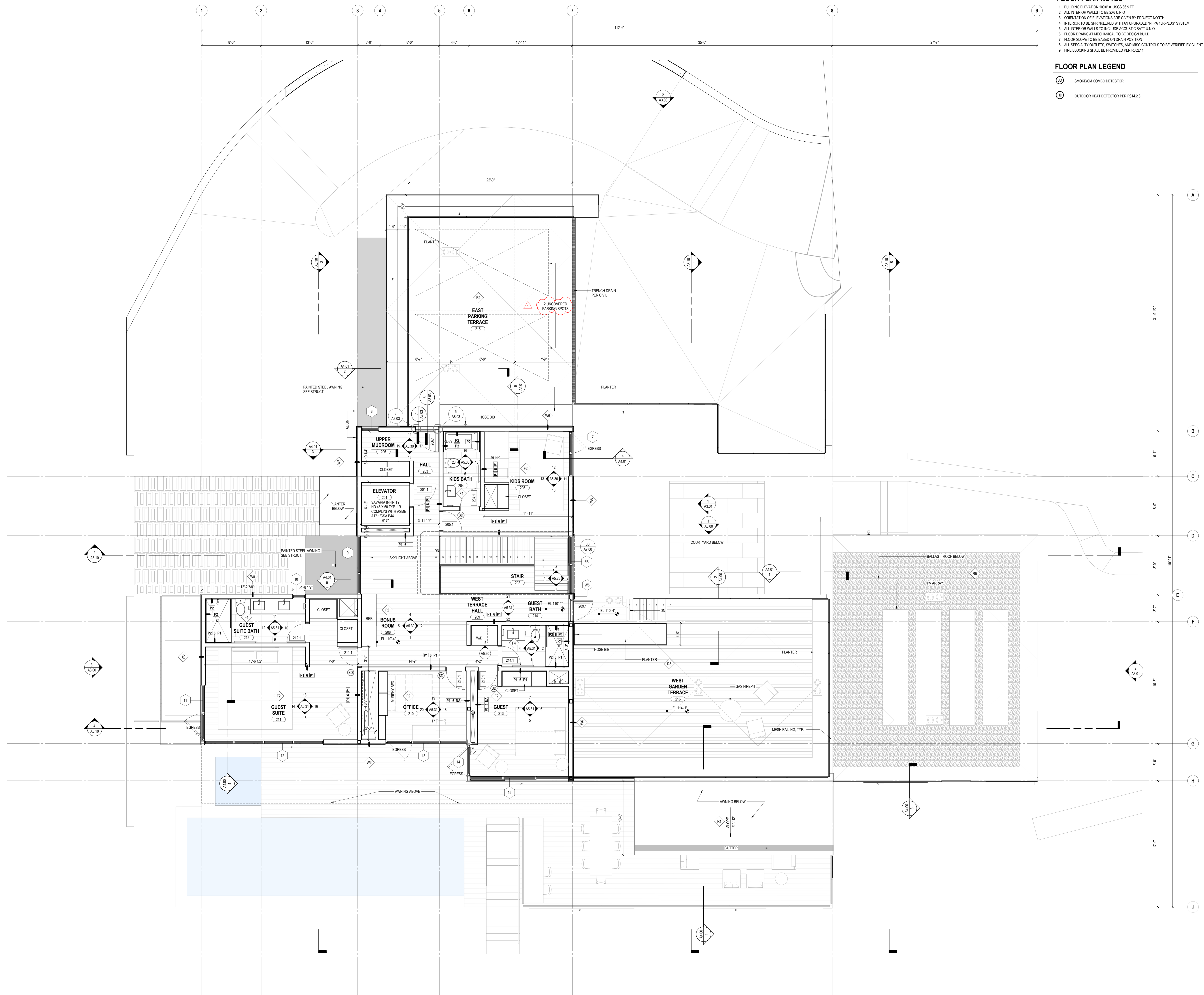

- FLOOR PLAN NOTES**
- BUILDING ELEVATION 100'0" - USGS 36.5 FT
 - ALL INTERIOR WALLS TO BE 2x8 U.N.O.
 - ORIENTATION OF ELEVATIONS ARE GIVEN BY PROJECT NORTH
 - INTERIOR TO BE SPRINKLED WITH AN UPGRADED "NFPA 13R PLUS" SYSTEM
 - ALL INTERIOR WALLS TO INCLUDE ACOUSTIC BATT U.N.O.
 - FLOOR DRAINS AT MECHANICAL TO BE DESIGN BUILD
 - FLOOR SLOPE TO BE BASED ON DRAIN POSITION
 - ALL SPECIALTY OUTLETS, SWITCHES, AND MISC CONTROLS TO BE VERIFIED BY CLIENT
 - FIRE BLOCKING SHALL BE PROVIDED PER R02.11

- FLOOR PLAN LEGEND**
- SMOKE/CO COMBO DETECTOR
 - OUTDOOR HEAT DETECTOR PER R214.2.3

Olson Kundig
 PROJECT: FUSED ELEMENTS
 4525 FOREST AVE SE MERCER ISLAND, WA 98040

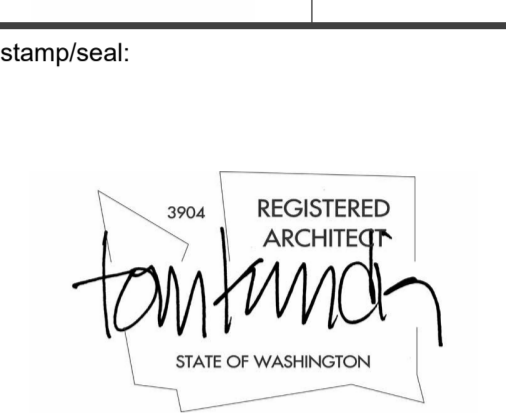

project architect: _____
 project manager: _____
 drawn by: _____
 checked by: _____
 job no.: _____

revisions:

1	02/23/24	R1 PERMIT
no.	date	description

PERMIT SET
 09/08/2023

UPPER LEVEL FLOOR PLAN

sheet: **A2.30**

1 UPPER LEVEL FLOOR PLAN
 SCALE: 1/4" = 1'-0"

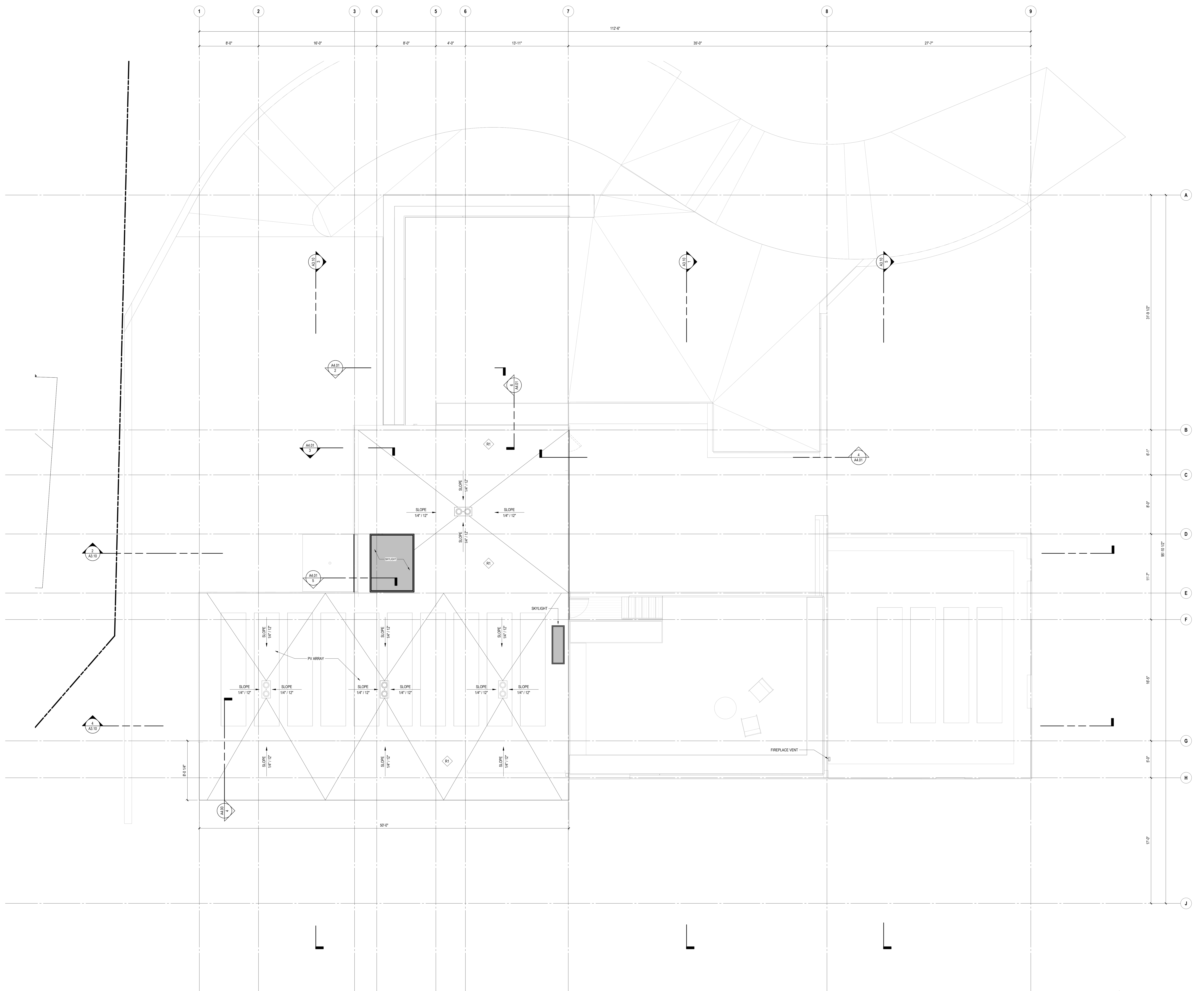

1 ROOF PLAN - MAIN ROOF
SCALE: 1/4" = 1'-0"

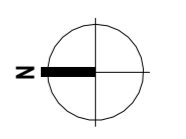

Olson Kundig
 project: FUSED ELEMENTS
 4525 FOREST AVE SE MERCER ISLAND WA 98040

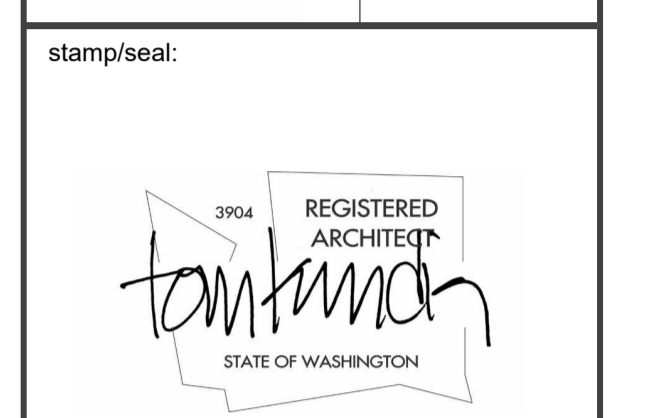

project architect:	_____
project manager:	_____
drawn by:	_____
checked by:	_____
job no.:	_____
revisions:	_____

no.:	date: description:

PERMIT SET
09/08/2023
 ROOF LEVEL FLOOR PLAN
 sheet: **A2.40**

ELEVATION LEGEND

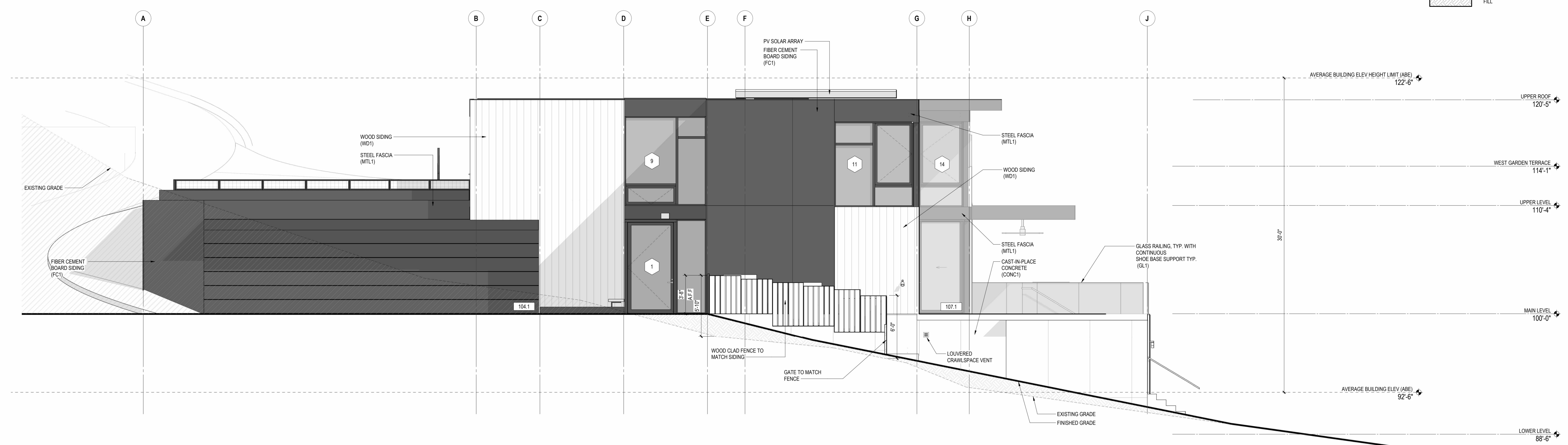
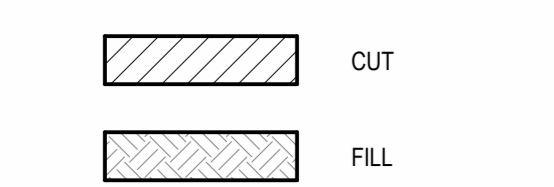

3 NORTH ELEVATION
SCALE: 1/4" = 1'-0"

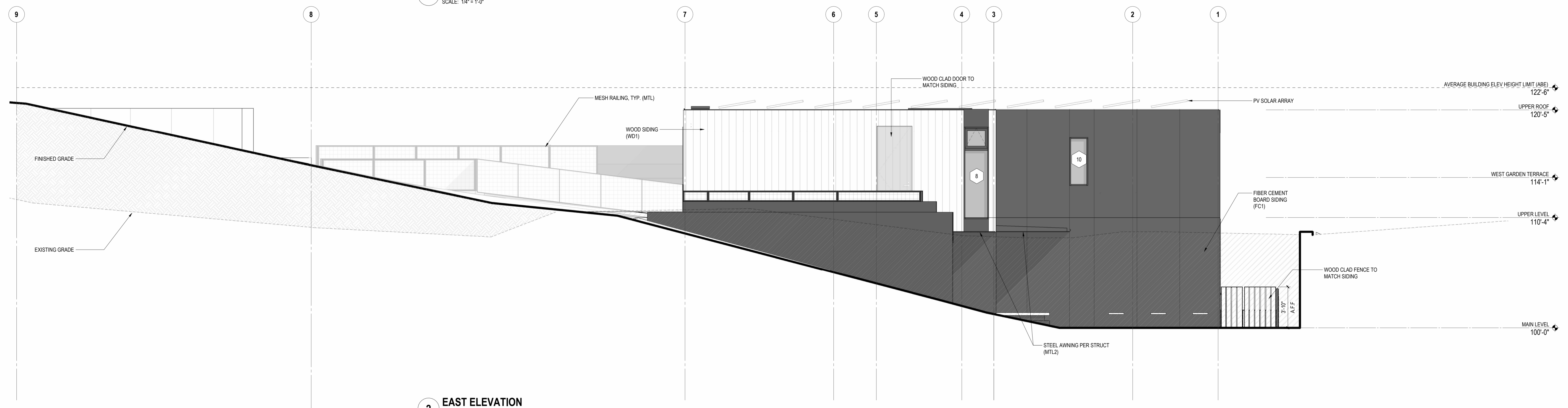

2 EAST ELEVATION
SCALE: 1/4" = 1'-0"

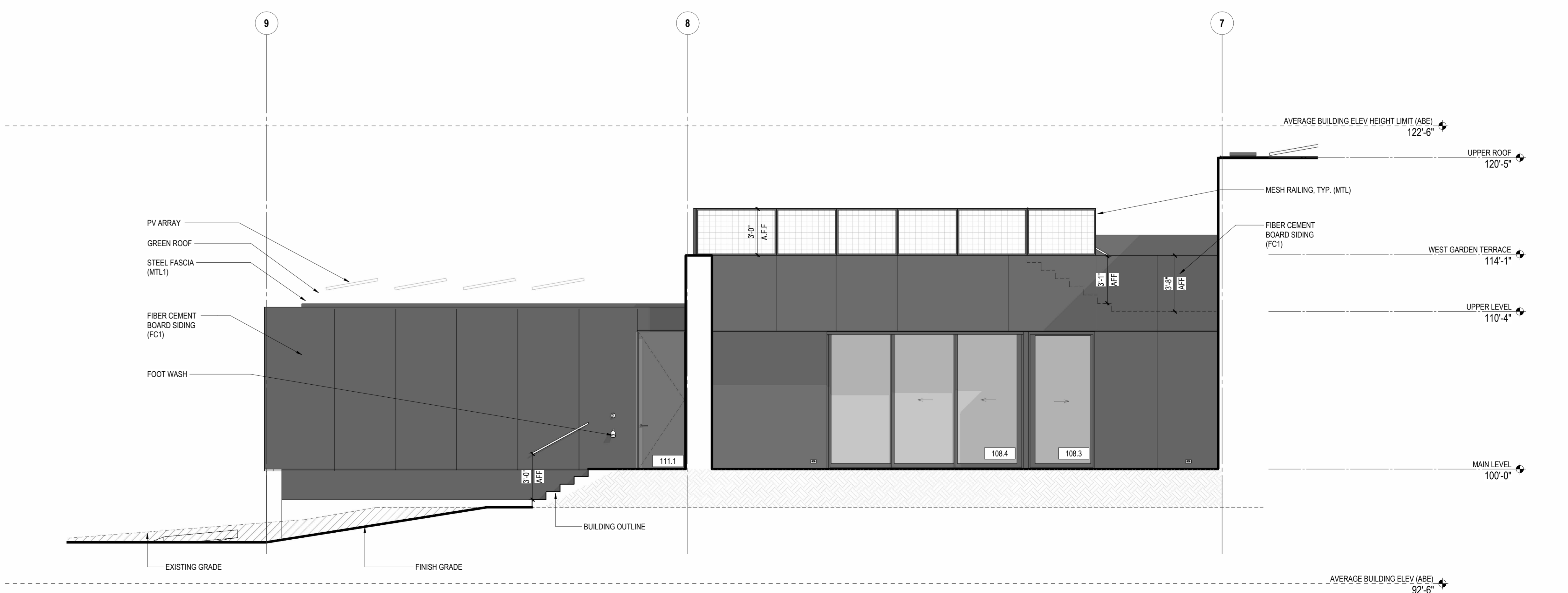

1 PARTIAL ELEVATION - EAST
SCALE: 1/4" = 1'-0"

EXTERIOR MATERIAL KEY

- CAST-IN-PLACE CONCRETE (CONC1)
SMOOTH PANEL-FORMED CONCRETE WITH EXPOSED TIE HOLES
- PAINTED STEEL TO MATCH WINDOWS (MTL1, MTL2)
STEEL SOFFIT
STEEL FASCIA
EXTERIOR COLUMNS
- METAL WINDOWS
THERMALLY BROKEN METAL WINDOWS
- VERTICAL FIBER CEMENT SIDING (FC1)
SWISS PEARL LARGO, BLACK OPAL TONES
- VERTICAL WOOD SIDING (WD1)
CEDAR SIDING WITH PINE TAR FINISH
- GLASS EXTERIOR GUARDRAILS WITH CONTINUOUS SHOE BASE SUPPORT TYP (GL1)

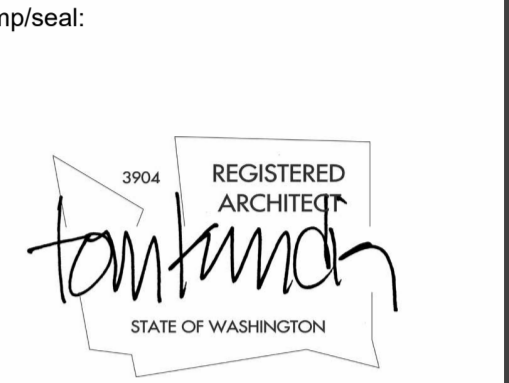

project architect: _____
 project manager: _____
 drawn by: _____
 checked by: _____
 job no.: _____

revisions:

no.: _____ date: _____ description: _____

PERMIT SET
09/08/2023

EXTERIOR ELEVATIONS
NORTH AND EAST

sheet: **A3.00**

ELEVATION LEGEND

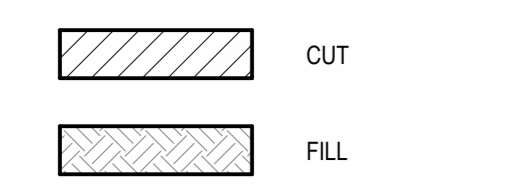

3 WEST ELEVATION
SCALE: 1/4" = 1'-0"

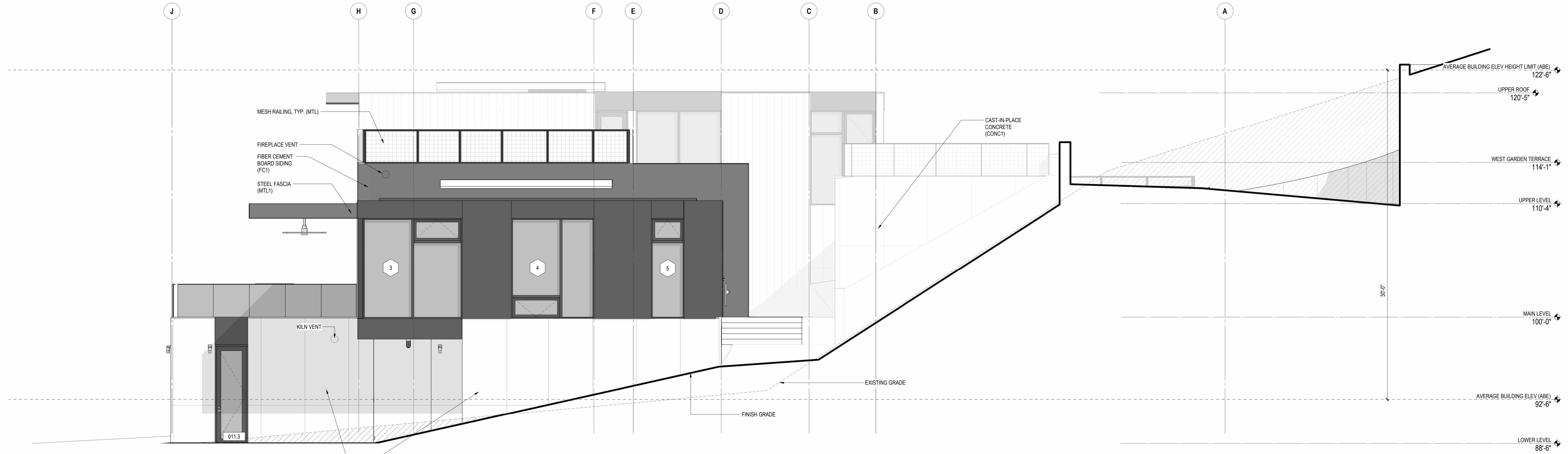

2 SOUTH ELEVATION
SCALE: 1/4" = 1'-0"

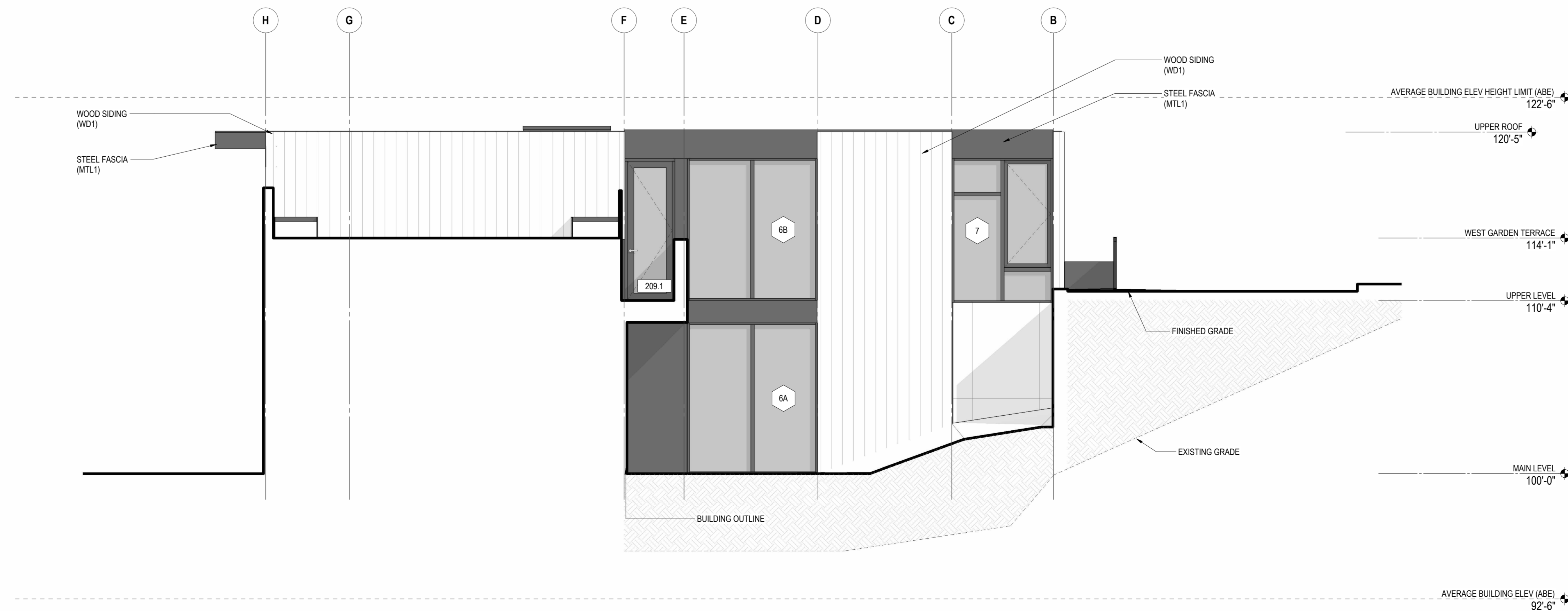

1 PARTIAL ELEVATION - SOUTH
SCALE: 1/4" = 1'-0"

EXTERIOR MATERIAL KEY

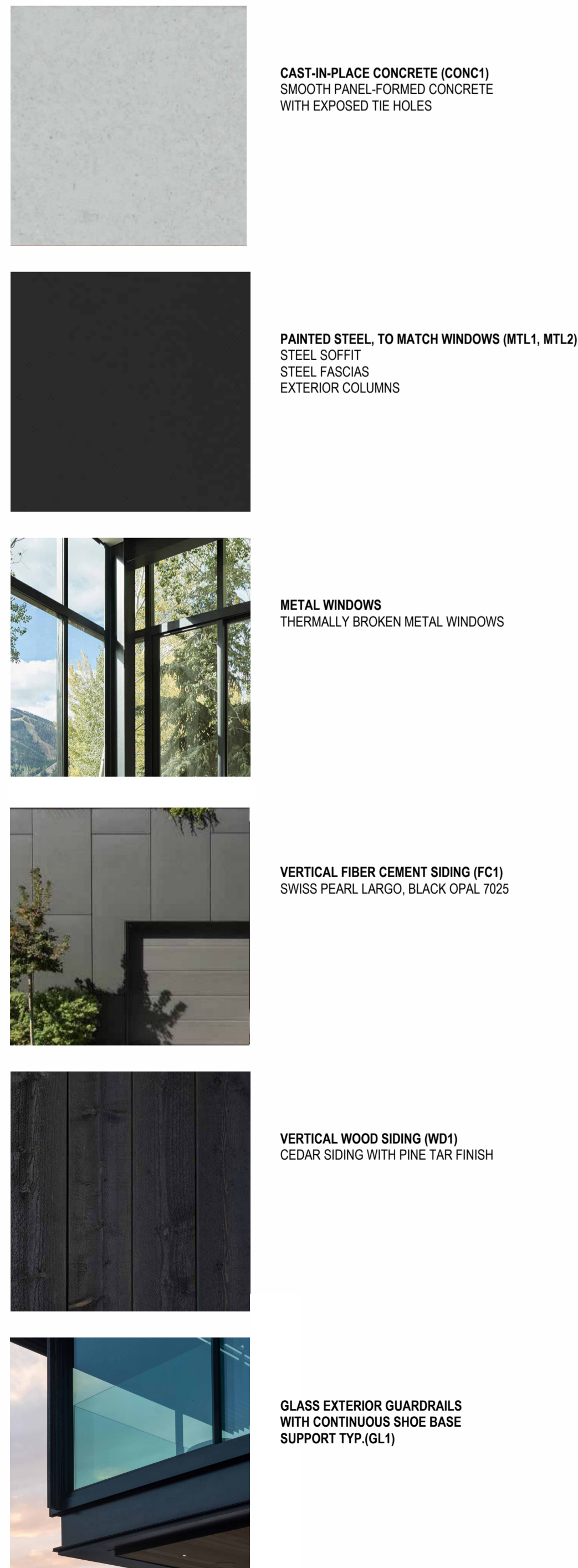

1918 South Jackson St. Suite 1000
Seattle, Washington 98148 USA
P: 206.451.1212
www.olsonkundig.com

Olson Kundig

PROJECT:
FUSED ELEMENTS
4525 FOREST AVE SE MERCER ISLAND, WA 98040

stamp/real:



project architect:
project manager:
drawn by:
checked by:
job no.:

revisions:

no.: date: description:

PERMIT SET
09/08/2023

95%:

EXTERIOR ELEVATIONS
SOUTH AND WEST

sheet:

A3.01



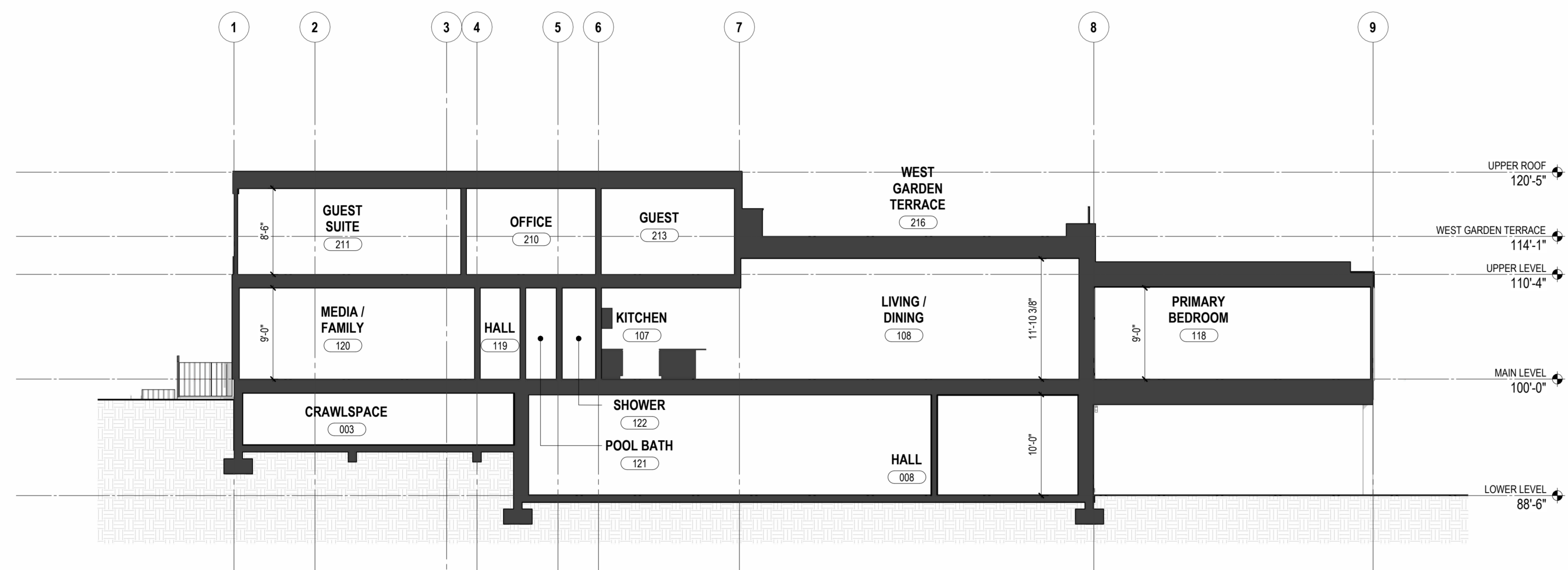

4 N-S LONGITUDINAL AT LIVING
SCALE: 1/8" = 1'-0"

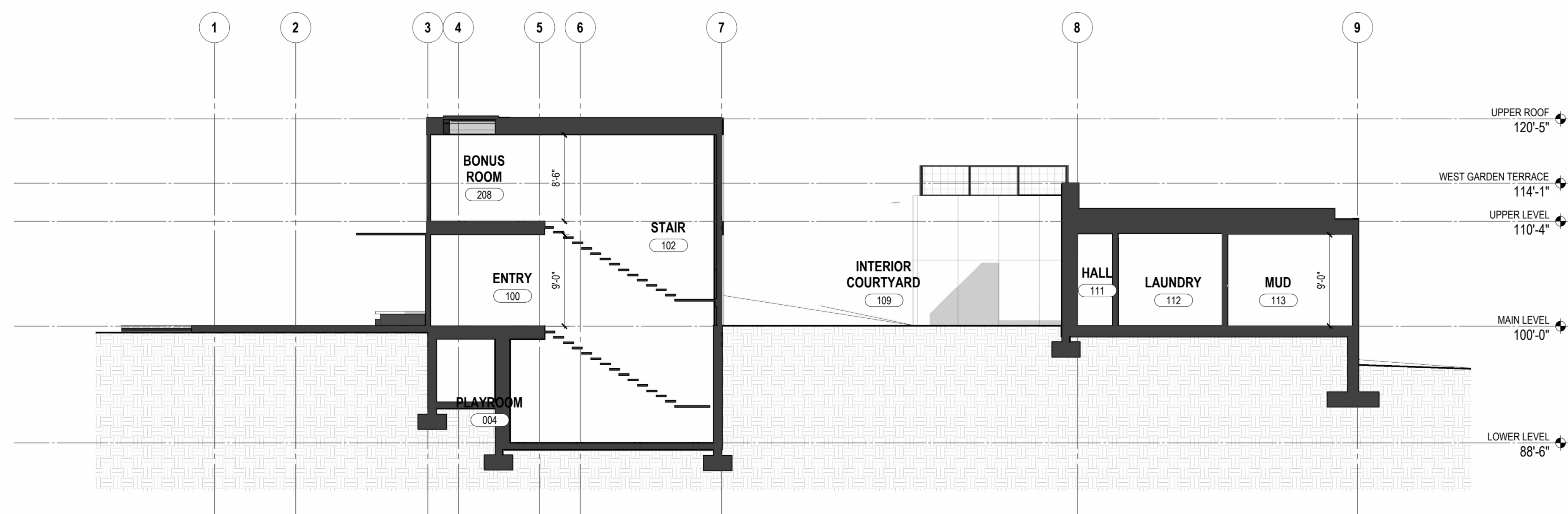

2 N-S LONGITUDINAL AT EXT COURTYARD
SCALE: 1/8" = 1'-0"

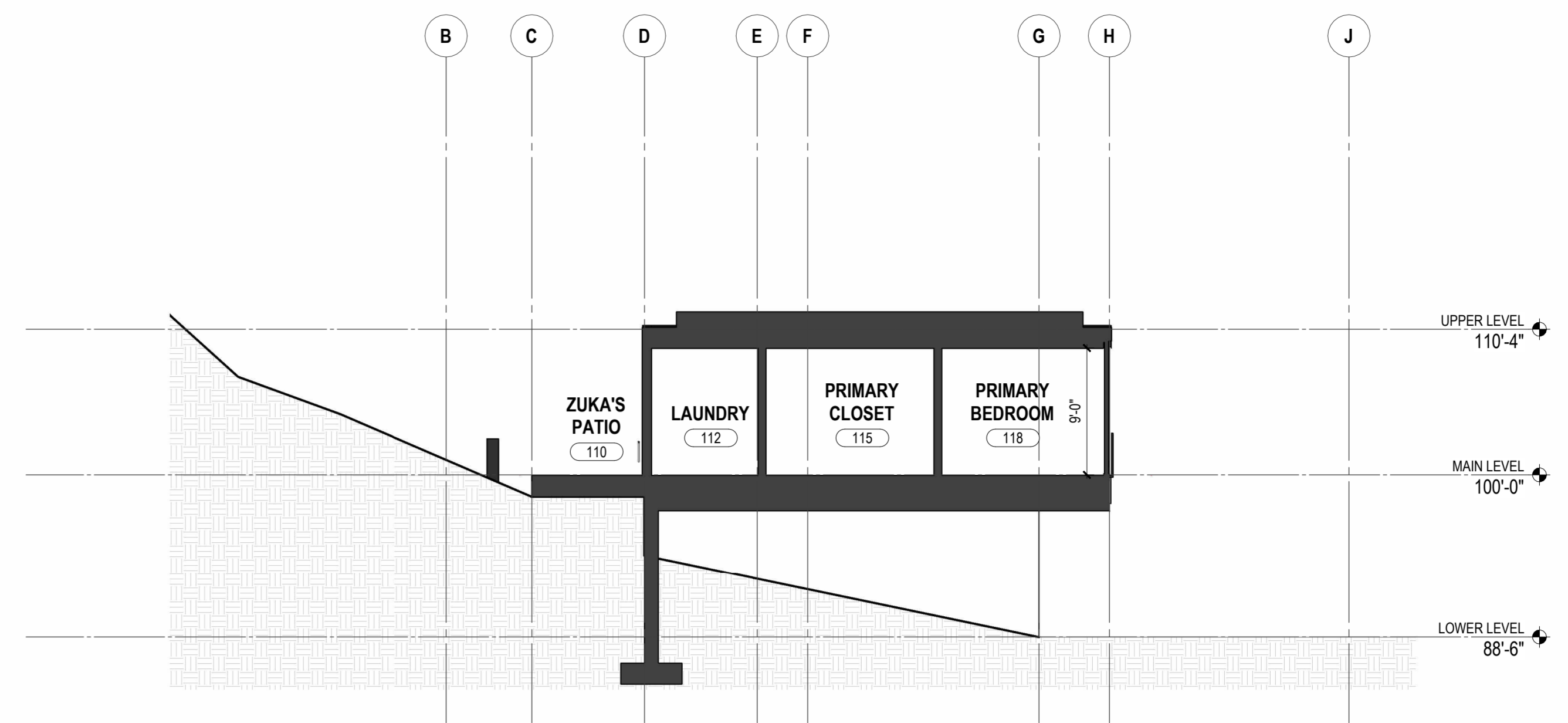

5 E-W SECTION AT PRIMARY SUITE
SCALE: 1/8" = 1'-0"

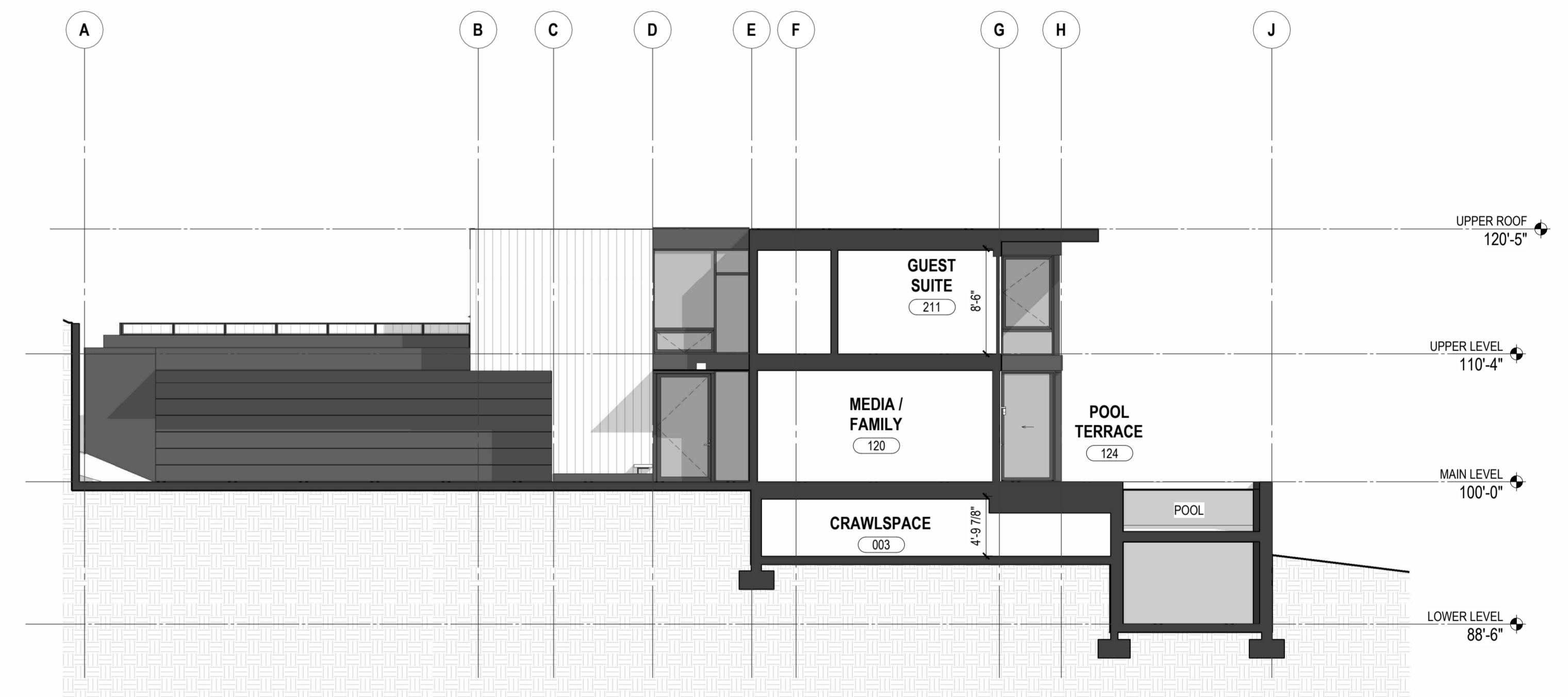

3 E-W SECTION AT GUEST SUITE
SCALE: 1/8" = 1'-0"

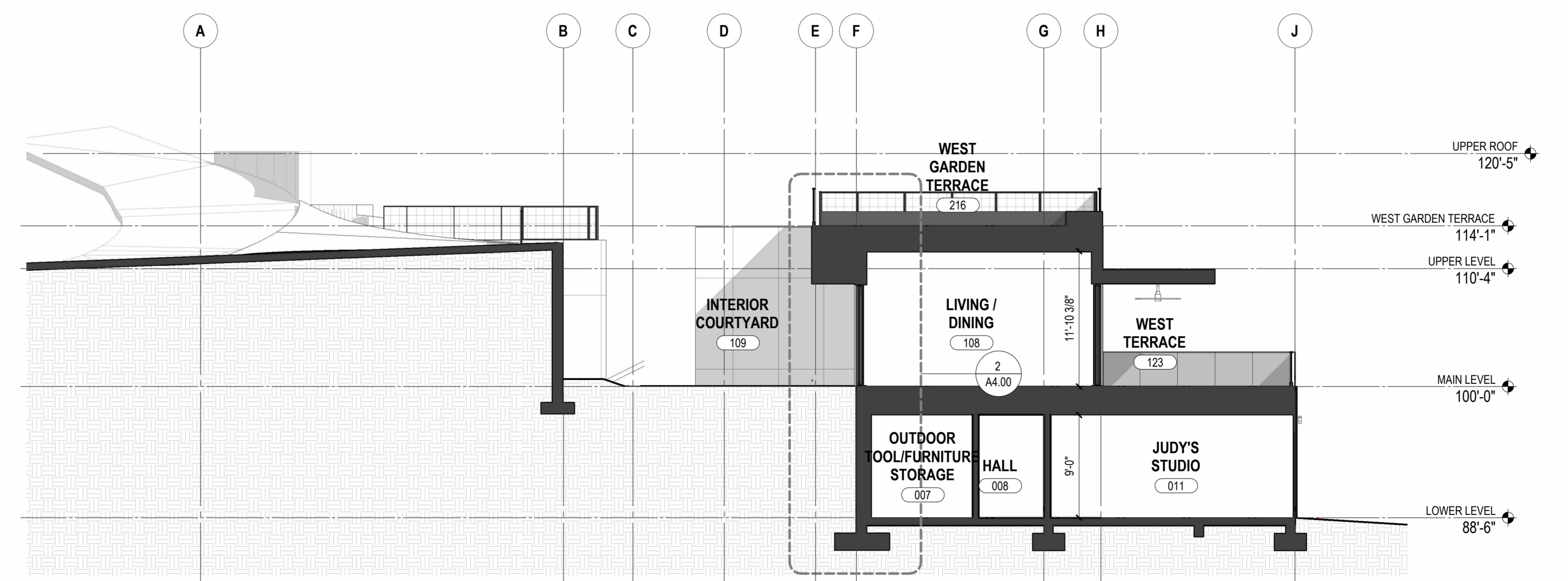

1 E-W SECTION AT EXT COURTYARD
SCALE: 1/8" = 1'-0"

stamp/seal:



project architect: _____
project manager: _____
drawn by: _____
checked by: _____
job no.: _____

revisions:

no.: date: description:

PERMIT SET
09/08/2023

BUILDING SECTIONS

sheet:
A3.10



REGISTERED ARCHITECT
 STATE OF WASHINGTON

stamp/seal:

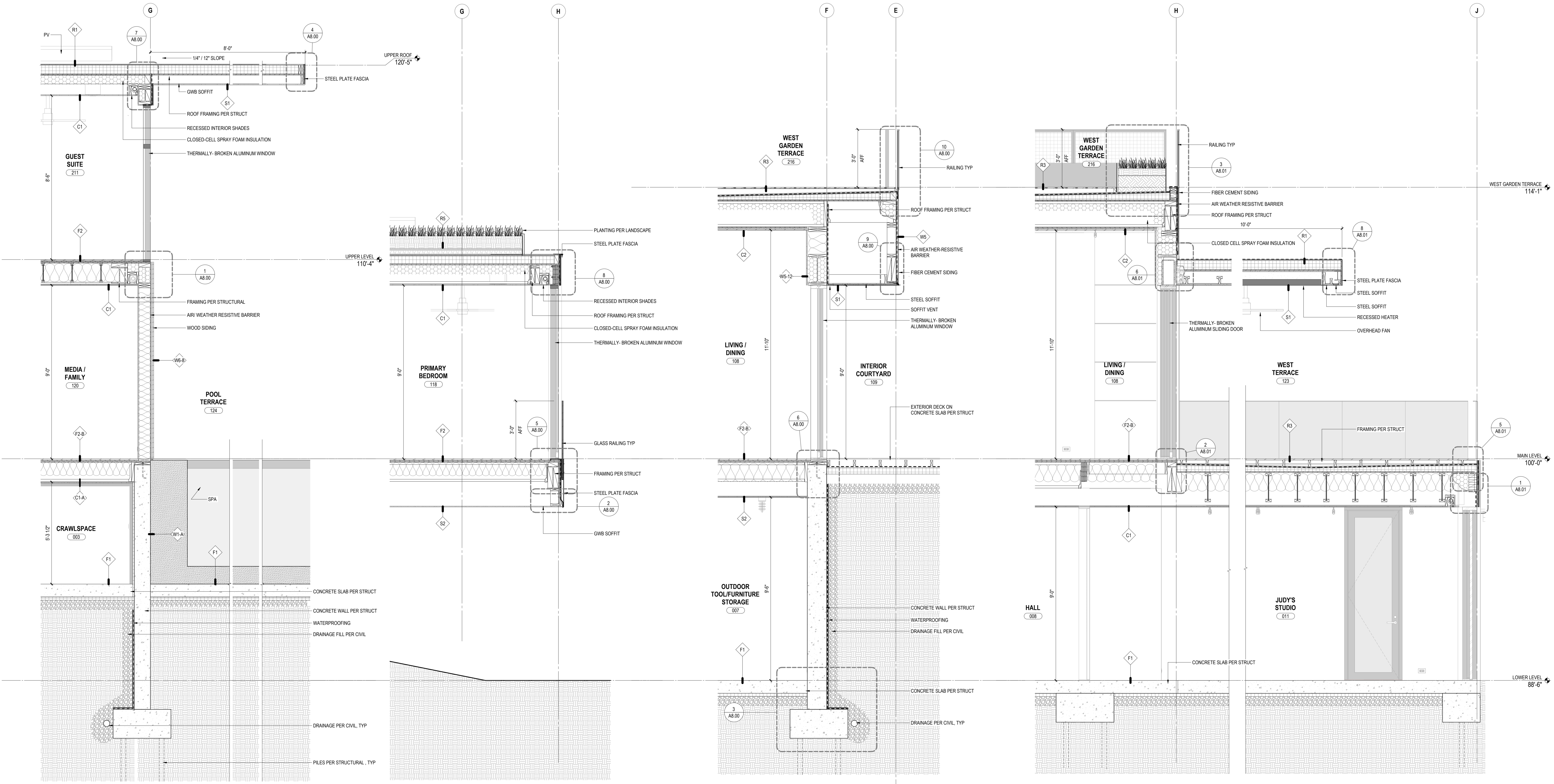

4 WEST GUEST WALL AT OVERHANG / SPA
 SCALE: 1/2" = 1'-0"

3 WEST AT PRIMARY SUITE/KAYAKE
 SCALE: 1/2" = 1'-0"

2 WEST LIVING WALL AT COURTYARD
 SCALE: 1/2" = 1'-0"

1 WEST LIVING WALL AT OVERHANG
 SCALE: 1/2" = 1'-0"

project architect: _____
 project manager: _____
 drawn by: _____
 checked by: _____
 job no.: _____

revisions:

no.	date	description

PERMIT SET
 09/08/2023

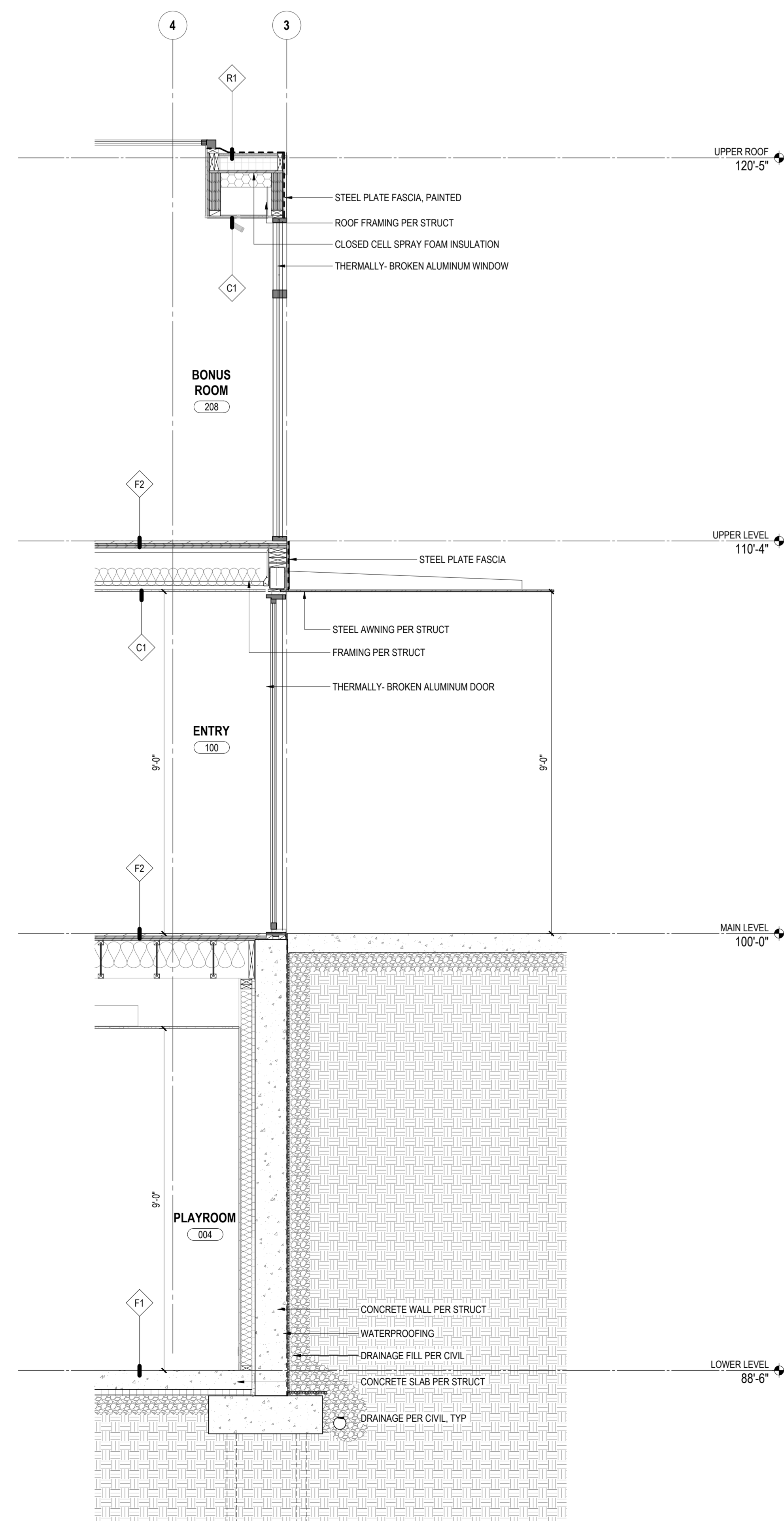

5 NORTH AT ENTRY / SKYLIGHT
SCALE: 1/2" = 1'-0"

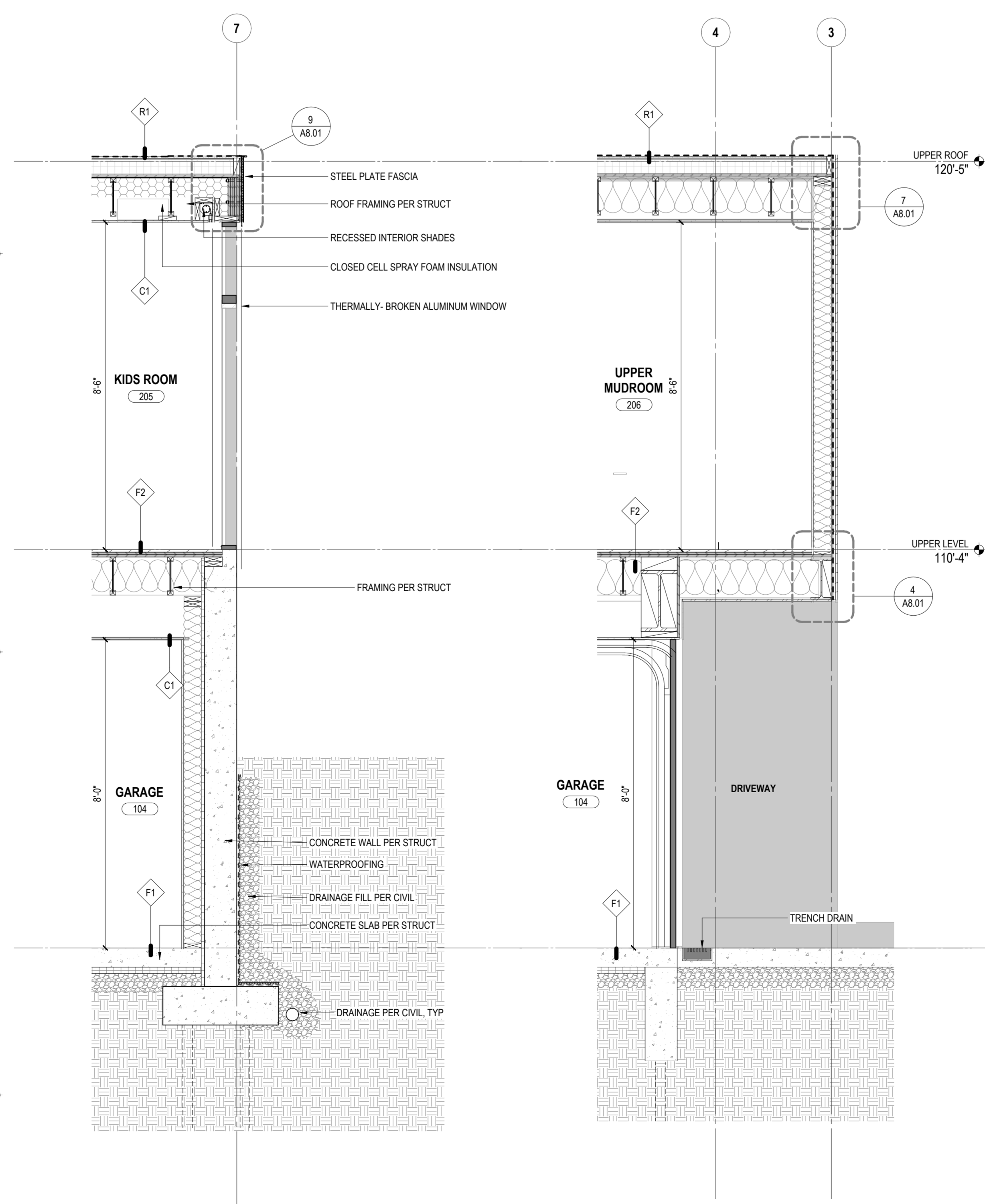

4 SOUTH AT GARAGE/KIDS
SCALE: 1/2" = 1'-0"

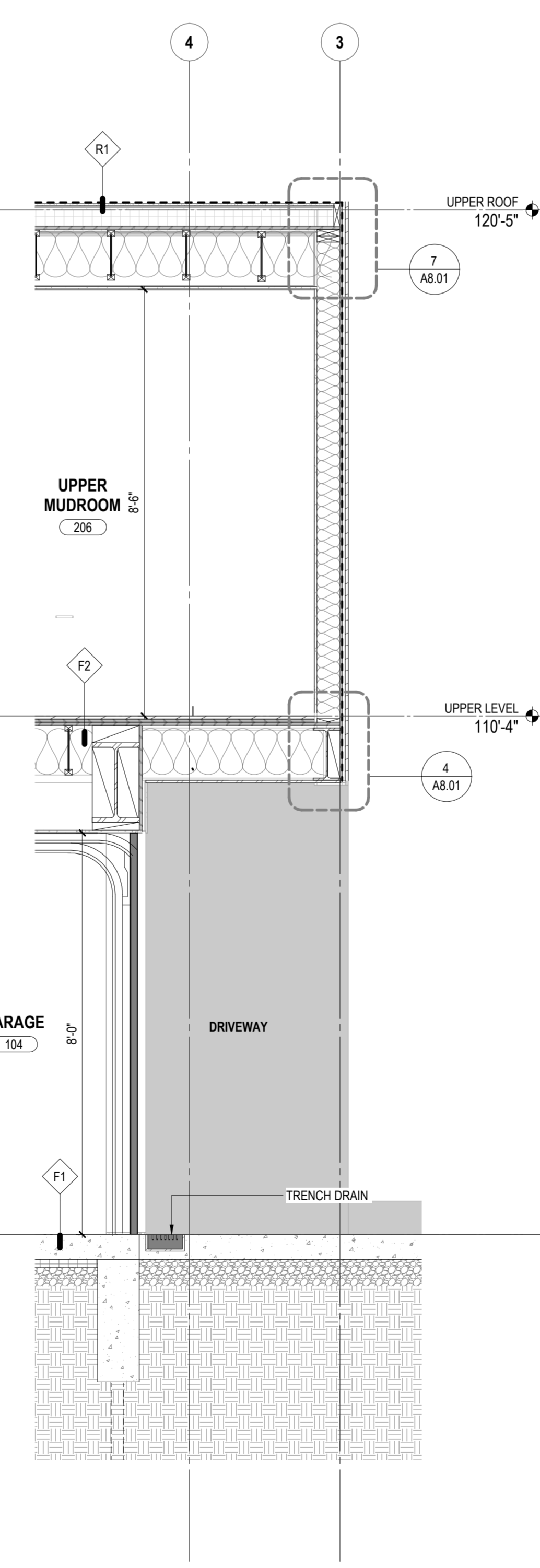

3 NORTH AT GARAGE CANTILEVER
SCALE: 1/2" = 1'-0"

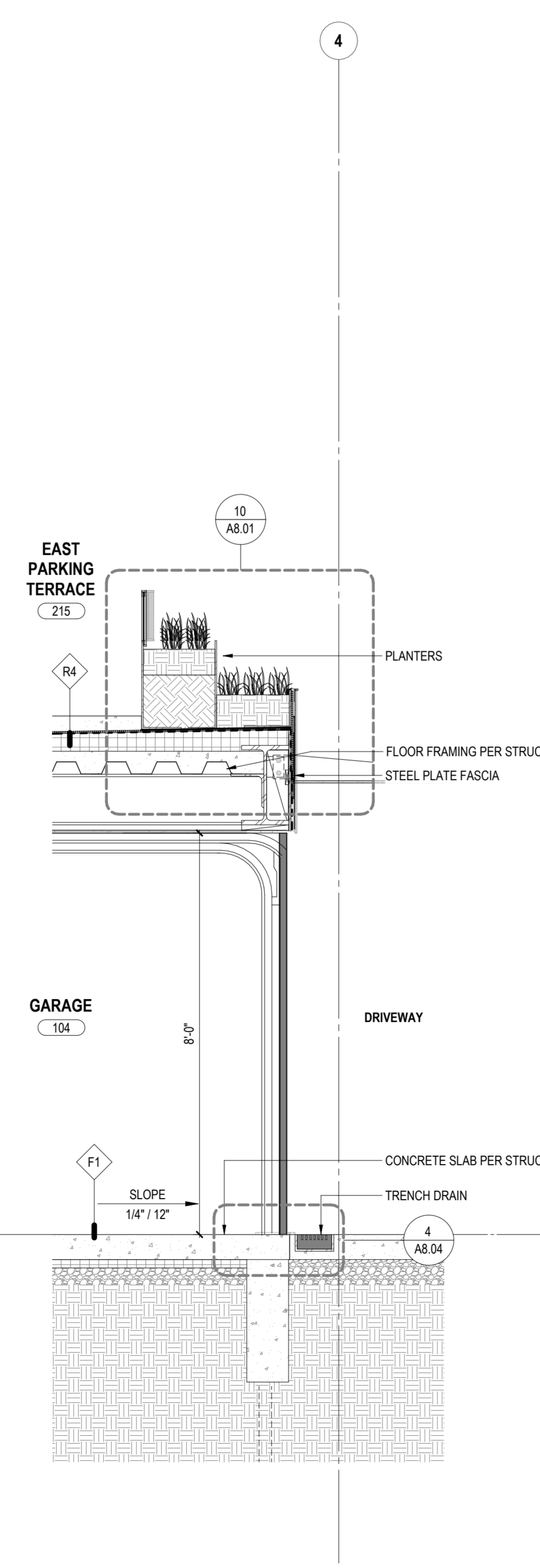

2 NORTH AT GARAGE ROOF PARKING
SCALE: 1/2" = 1'-0"

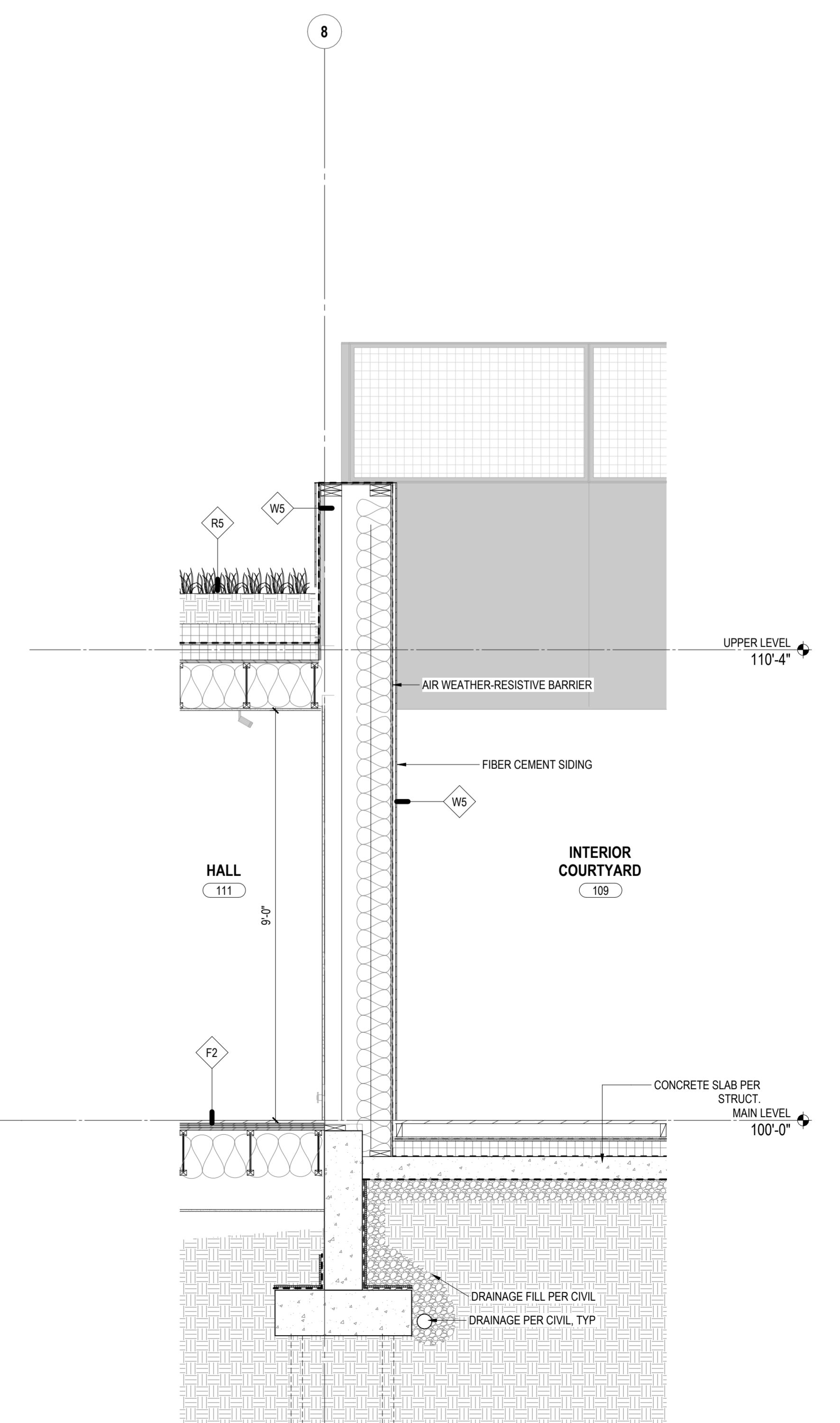

1 SOUTH AT COURTYARD / LL HALL
SCALE: 1/2" = 1'-0"

6 EAST AT GARAGE/PARKING TERRACE
SCALE: 1/2" = 1'-0"

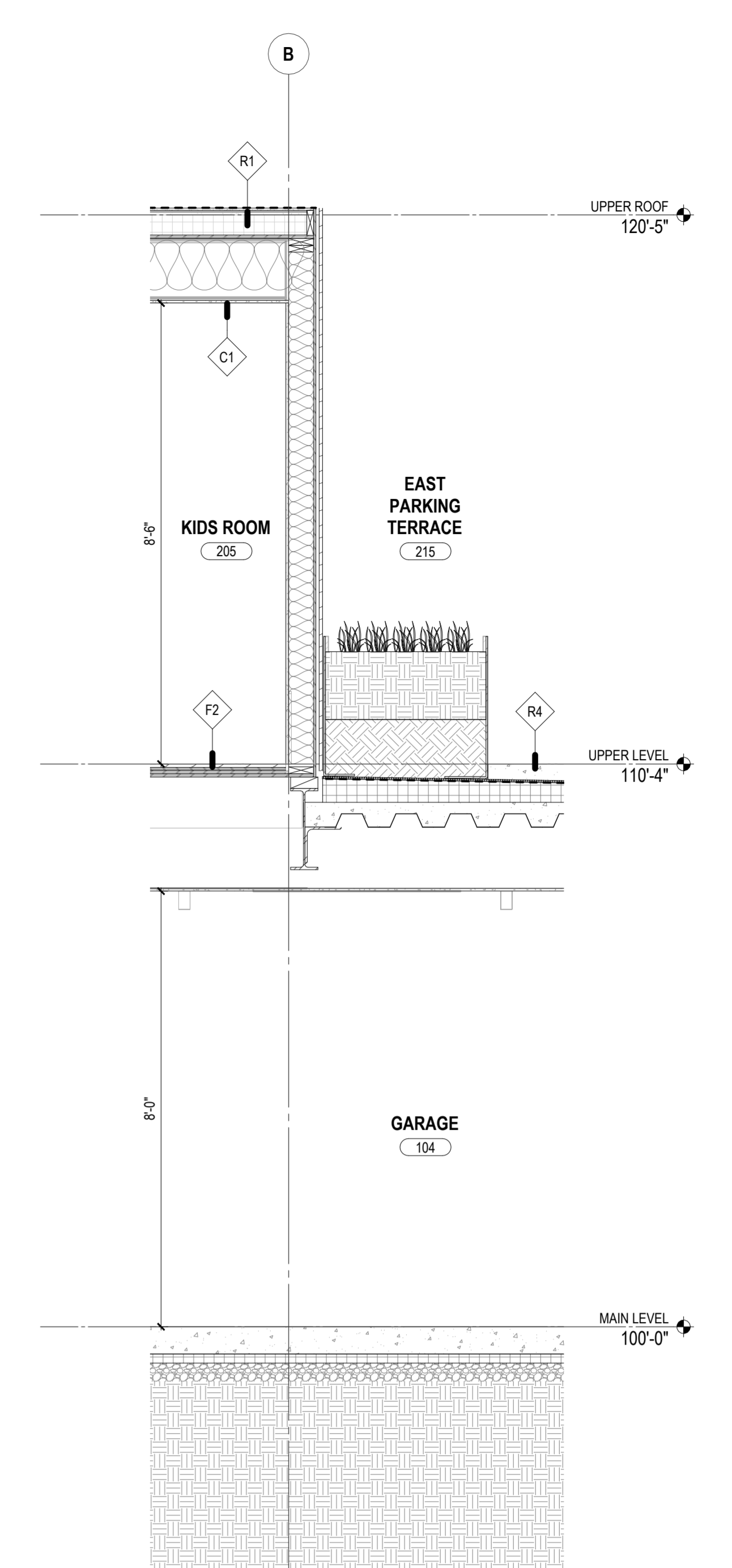

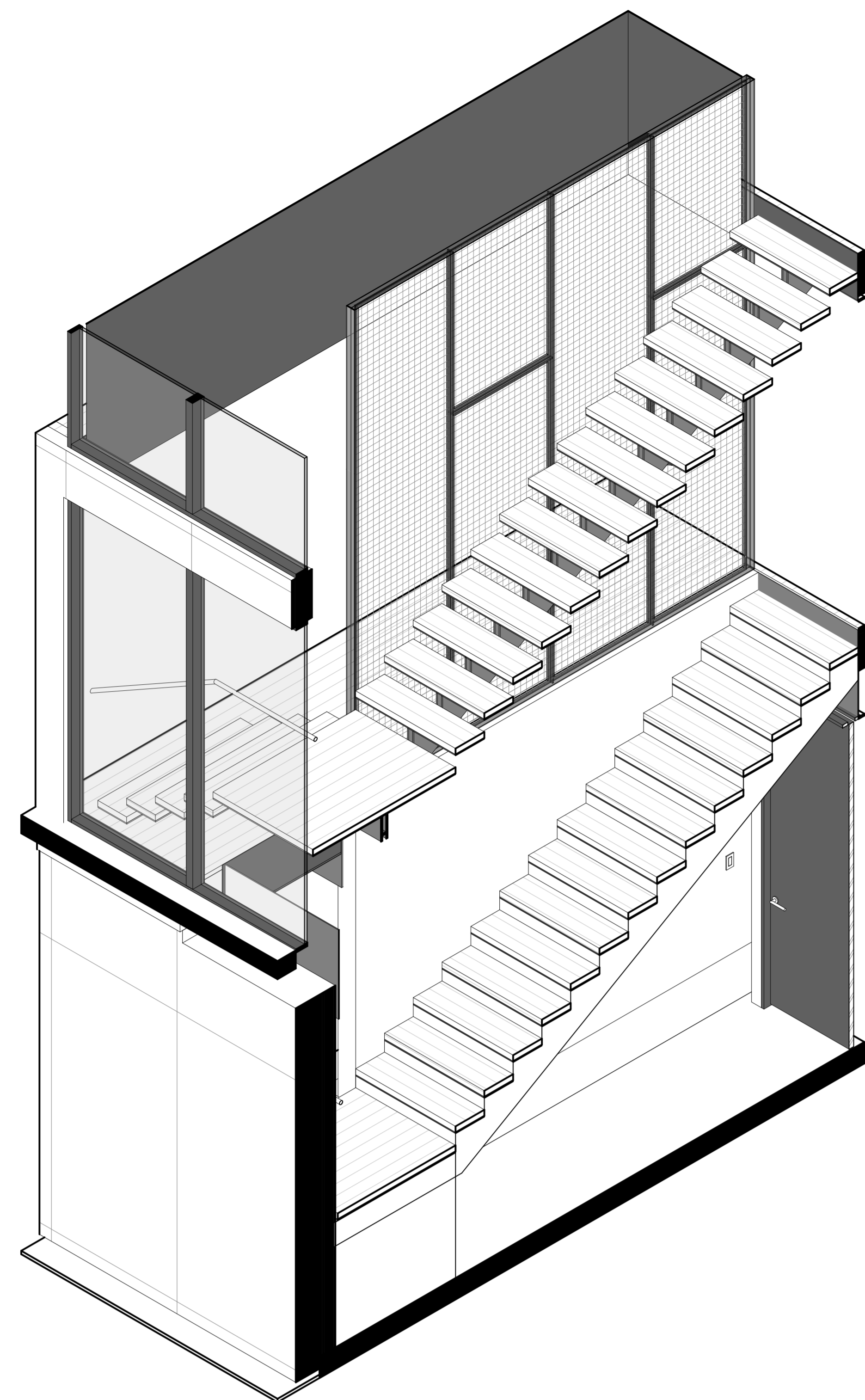

6 STAIR 102 - AXON WEST
SCALE:

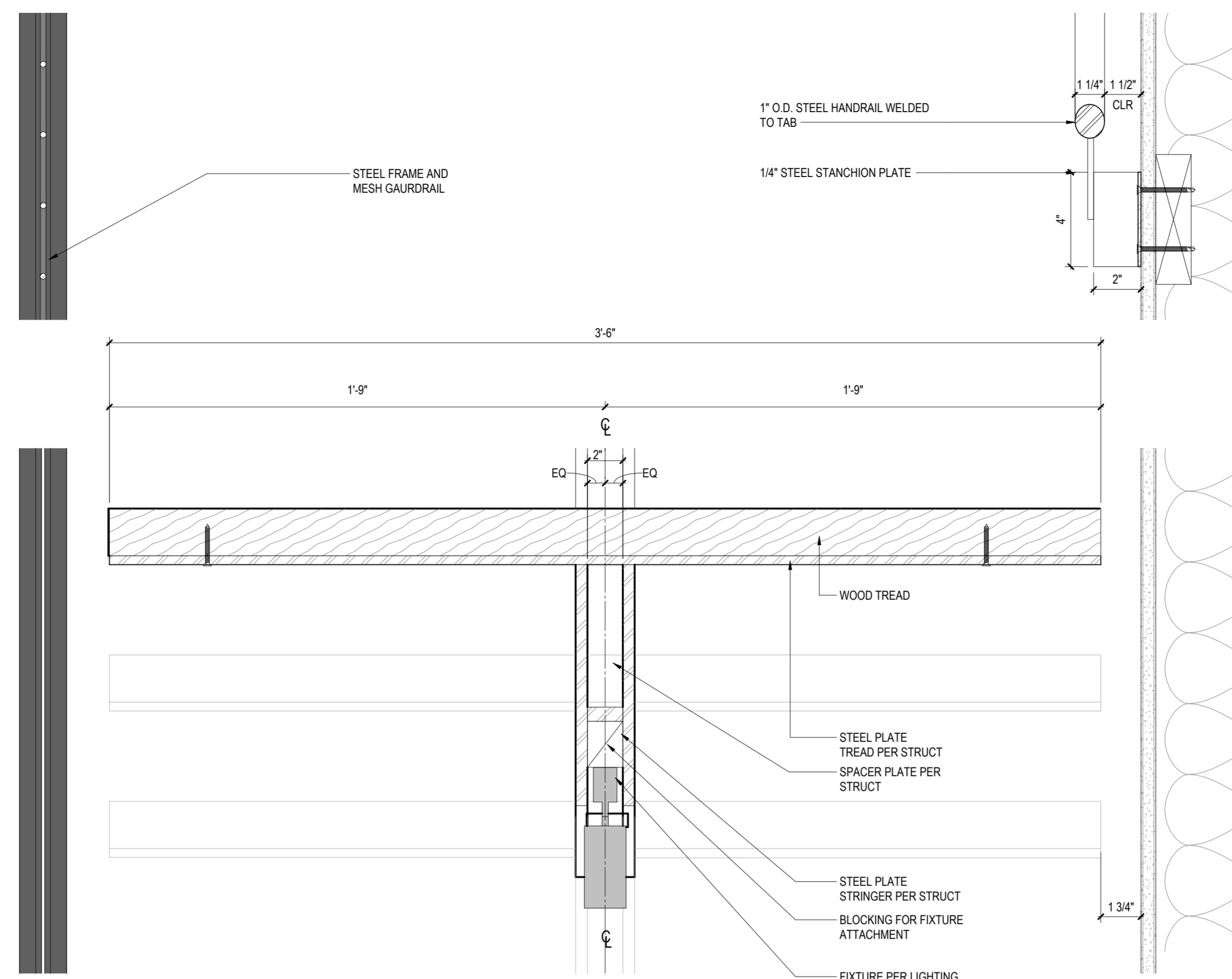

4A STAIR 102 - SECTION
SCALE: 3" = 1'-0"

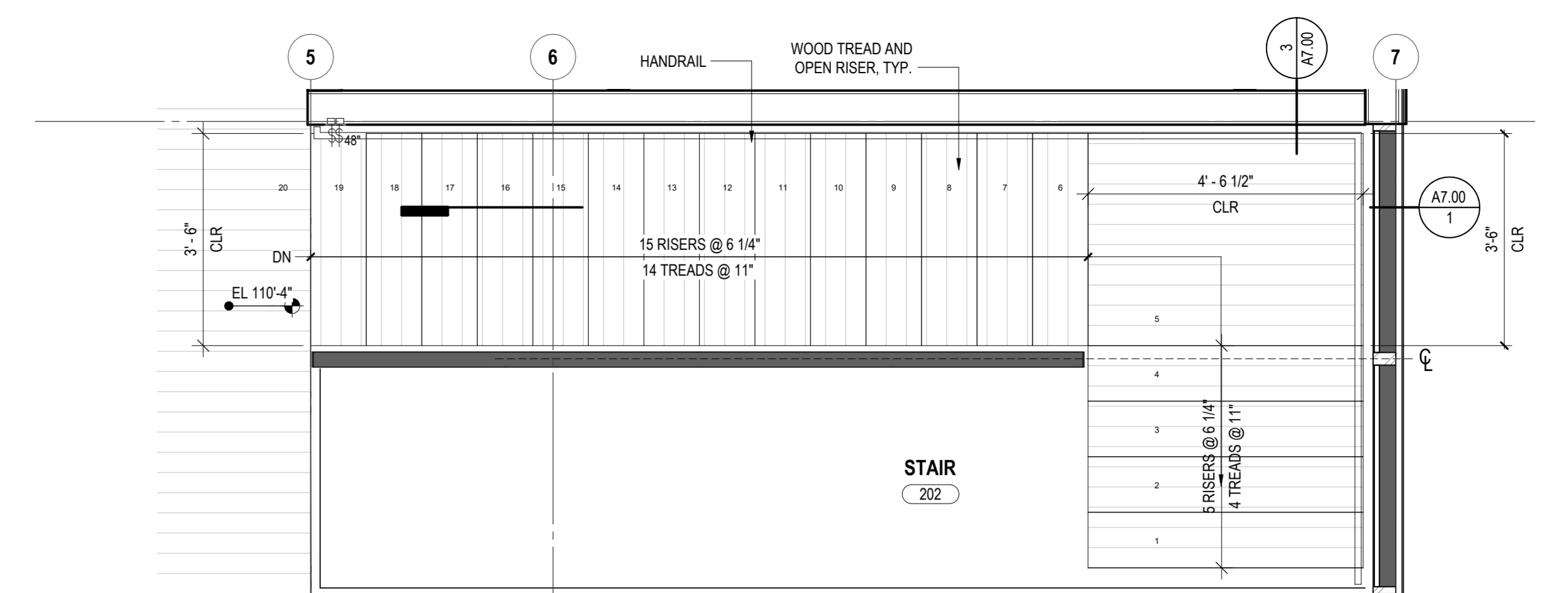

5B STAIR 102 - UPPER LEVEL PLAN
SCALE: 1/2" = 1'-0"

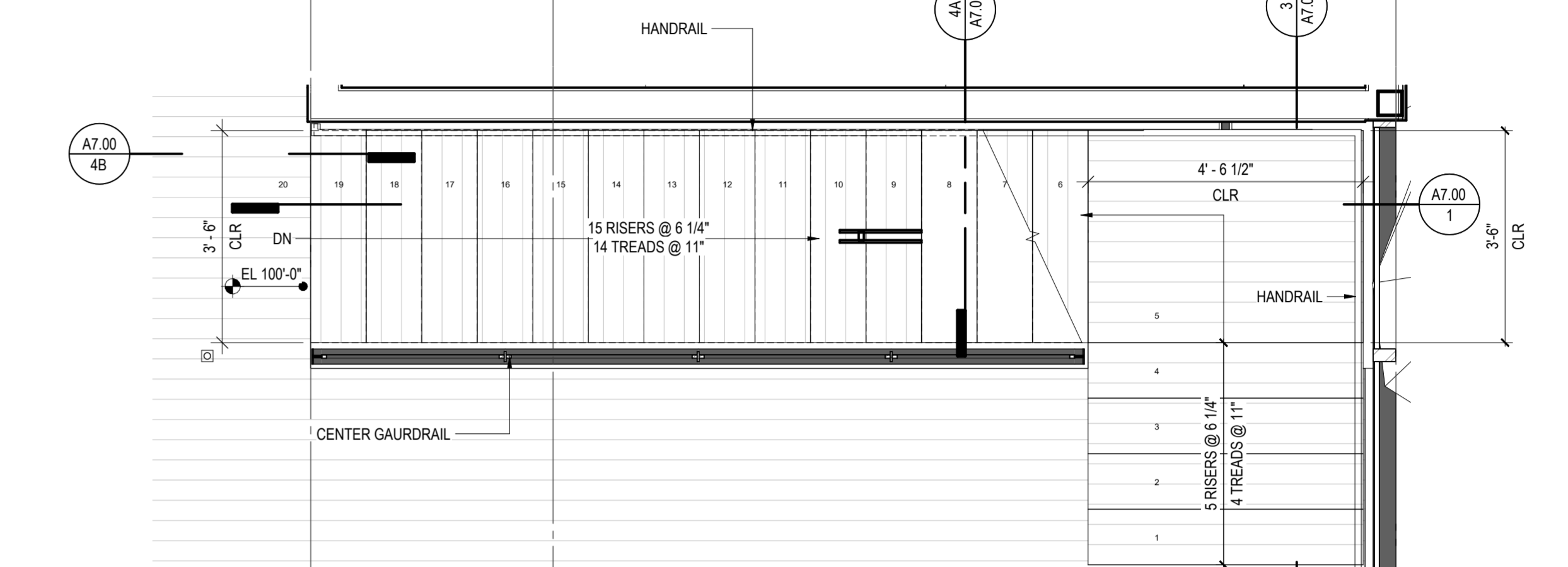

5A STAIR 102 - MAIN LEVEL PLAN
SCALE: 1/2" = 1'-0"

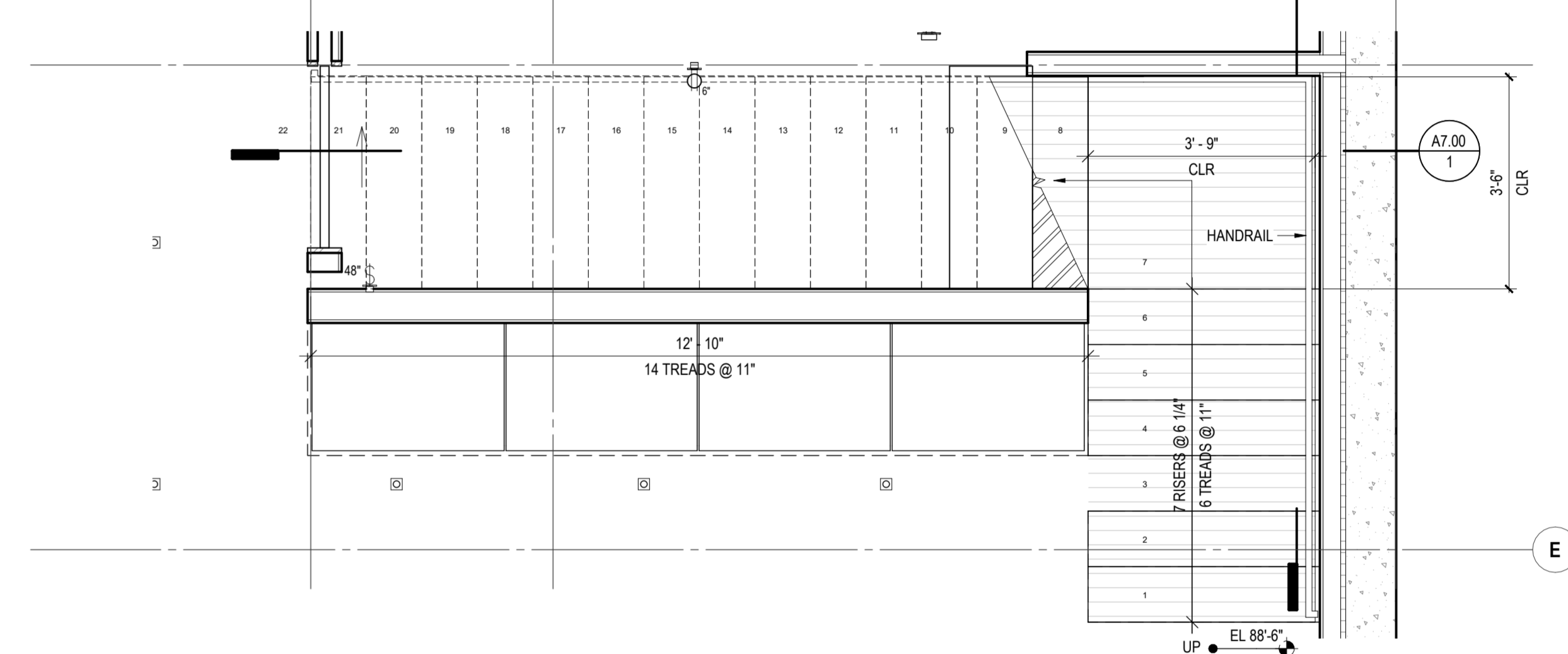

5 STAIR 102 - LOWER LEVEL PLAN
SCALE: 1/2" = 1'-0"

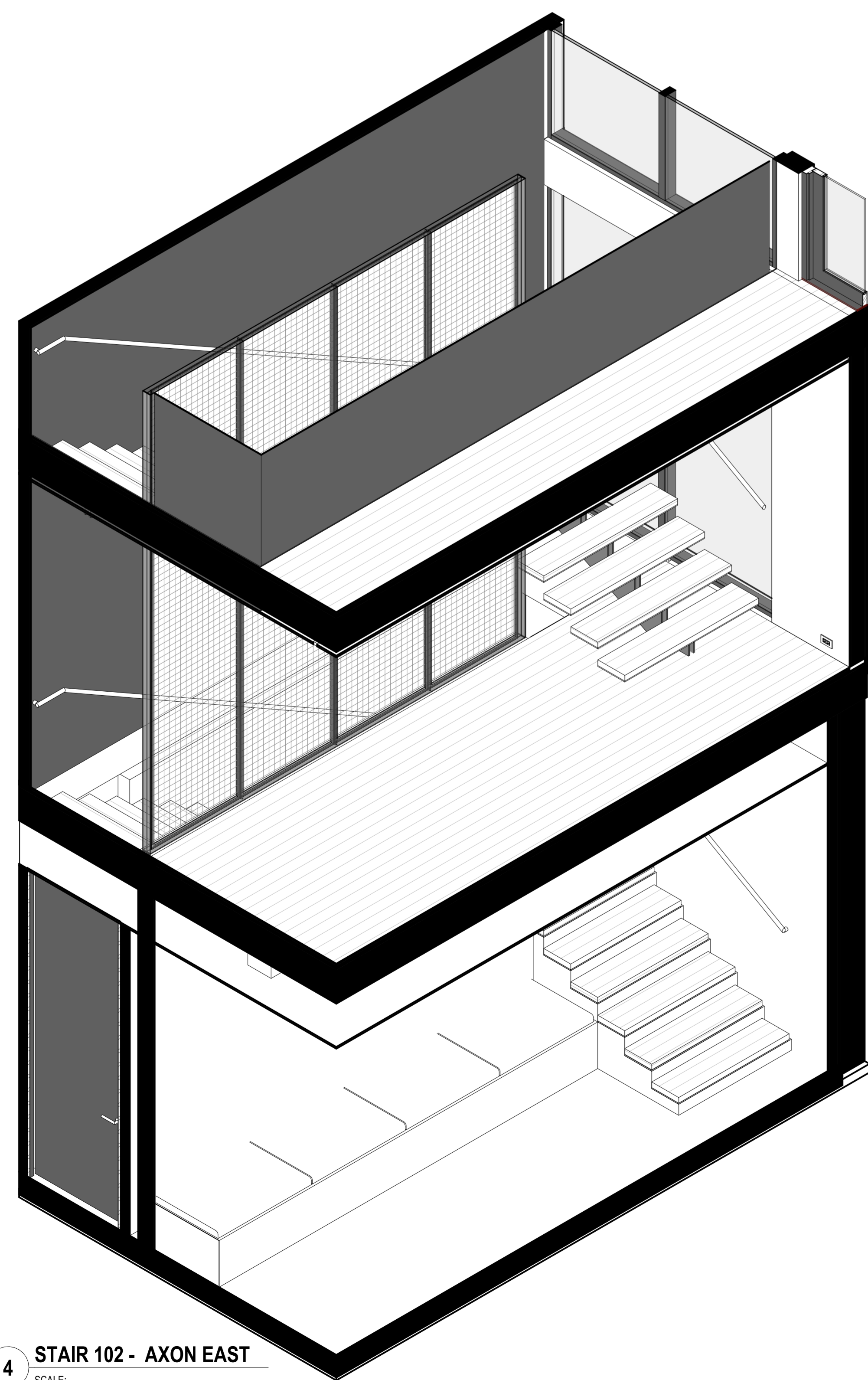

4 STAIR 102 - AXON EAST
SCALE:

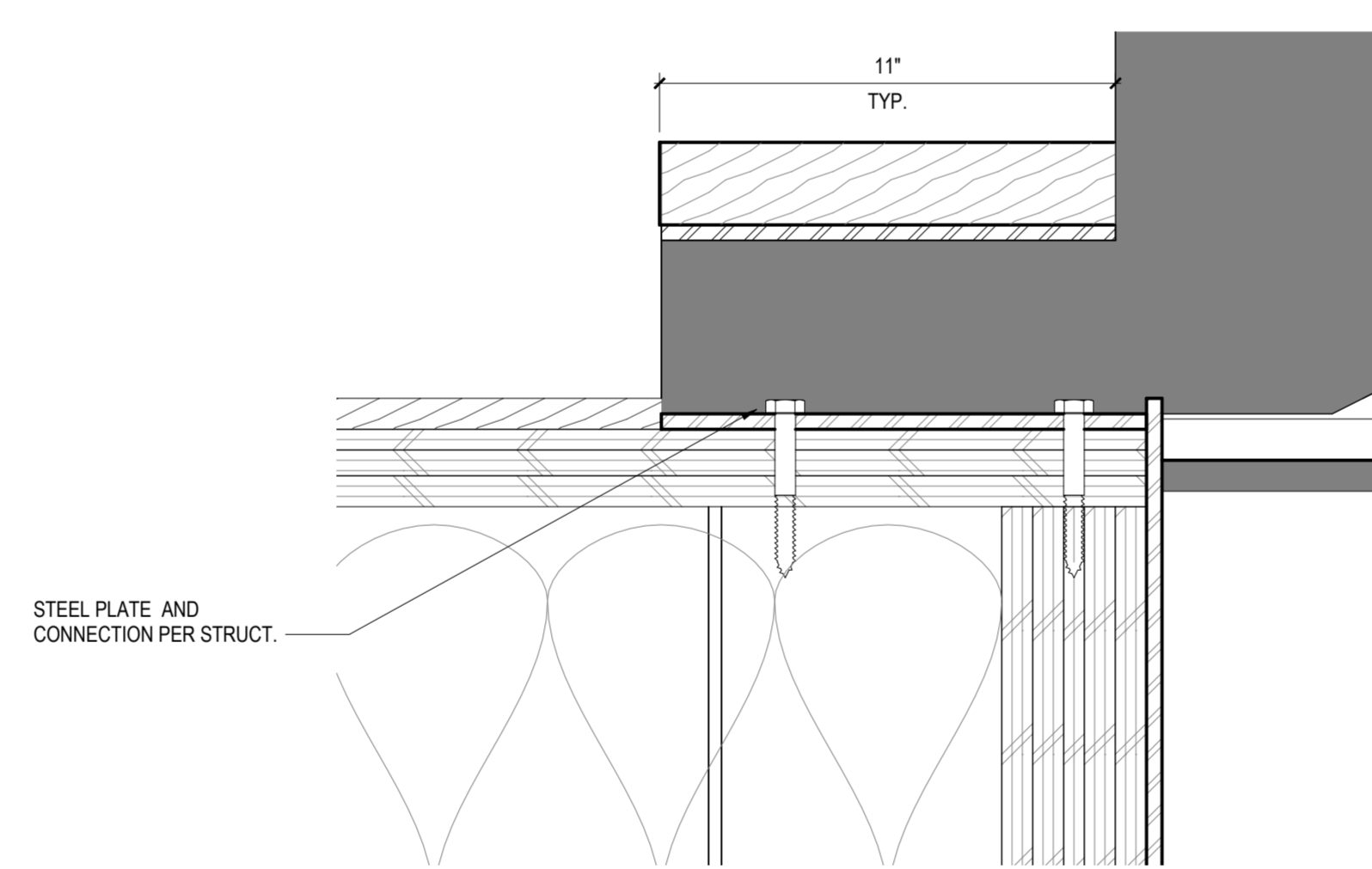

2 TYP STAIR AT LOWER FINISH FLOOR
SCALE: 3" = 1'-0"

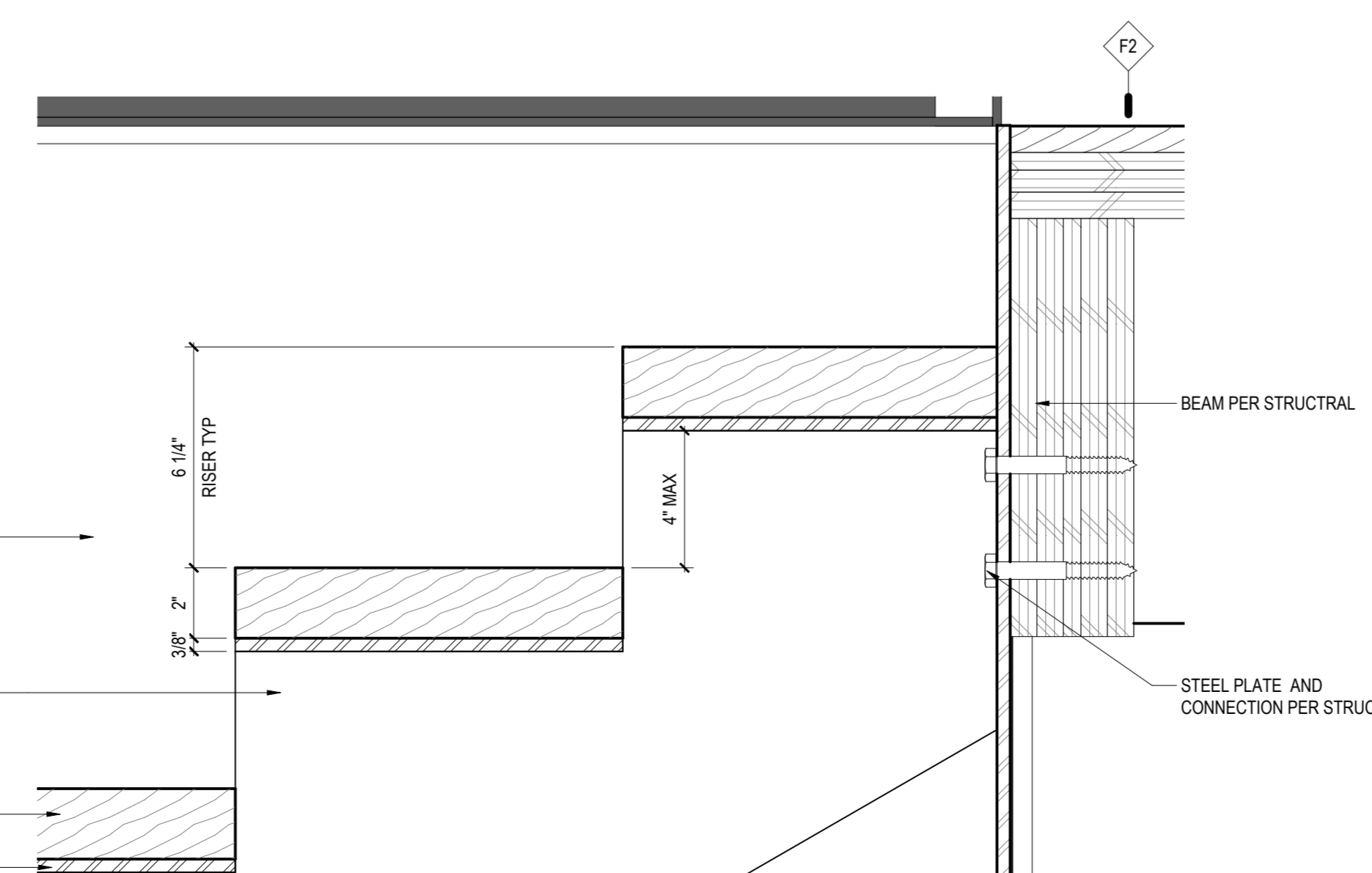

4B TYP STAIR 102 - TREAD DETAIL
SCALE: 3" = 1'-0"

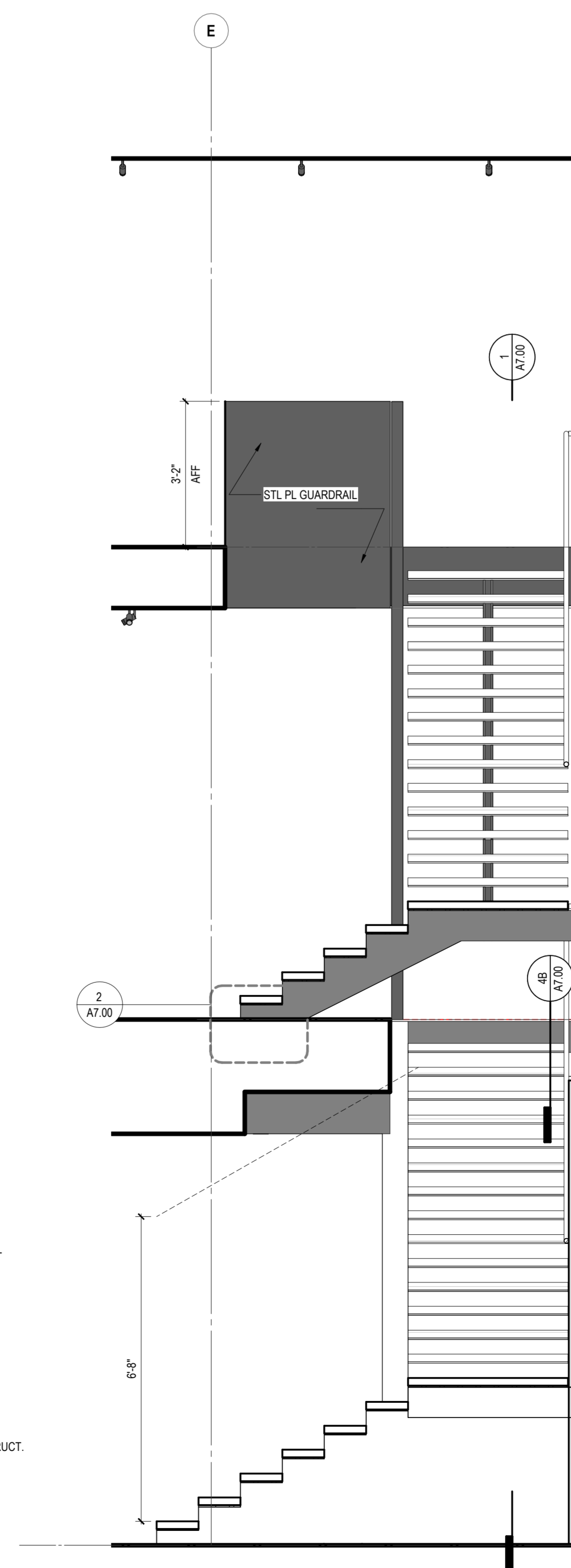

3 STAIR 102 - E-W SECTION
SCALE: 1/2" = 1'-0"

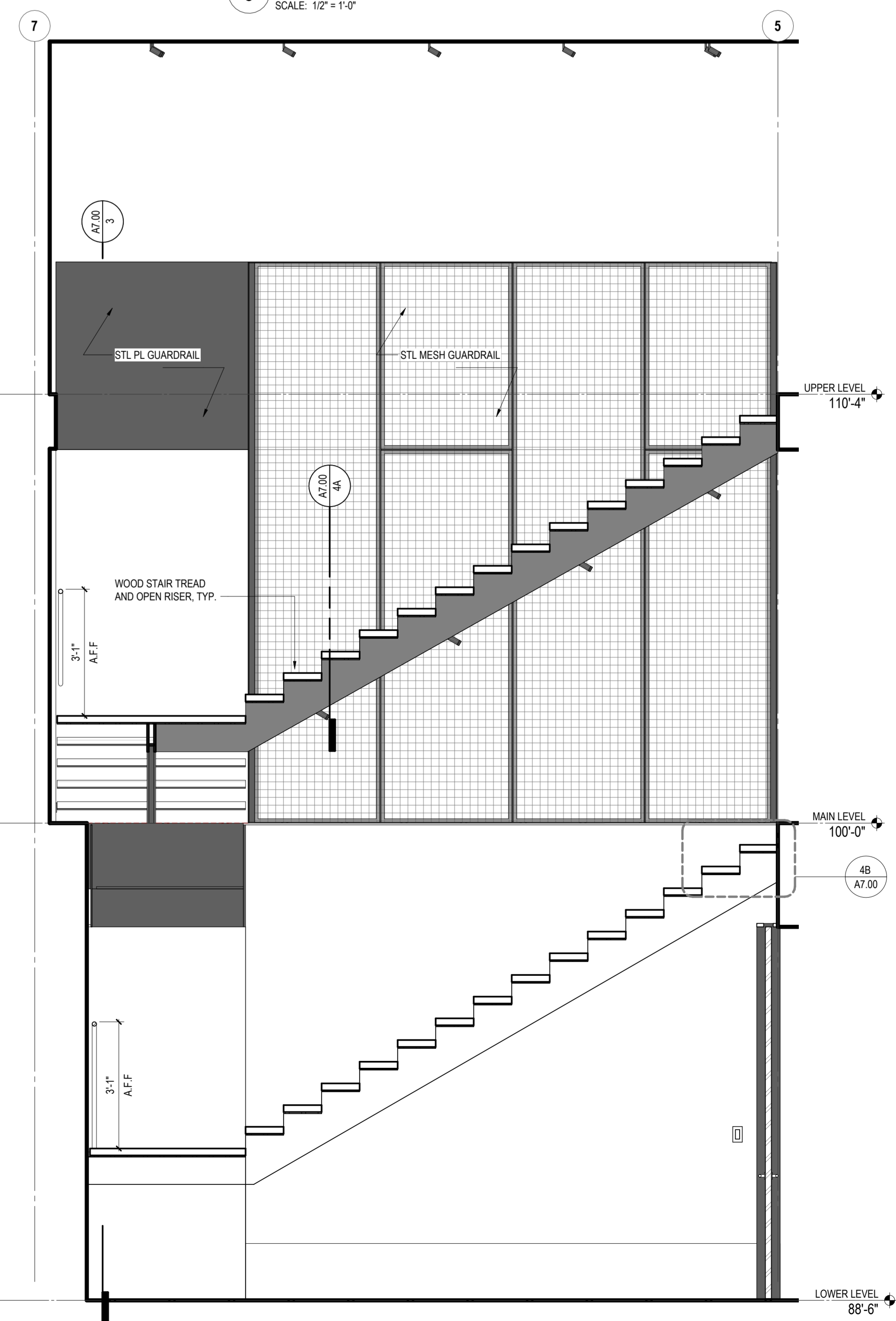

1 STAIR 102 - N-S SECTION
SCALE: 1/2" = 1'-0"

stamp/meal:



2024 REGISTERED ARCHITECT
STATE OF WASHINGTON

project architect: _____
project manager: _____
drawn by: _____
checked by: _____
job no.: _____

revisions:

no.	date	description

PERMIT SET
09/08/2023

950:

VERTICAL CIRCULATION

sheet:

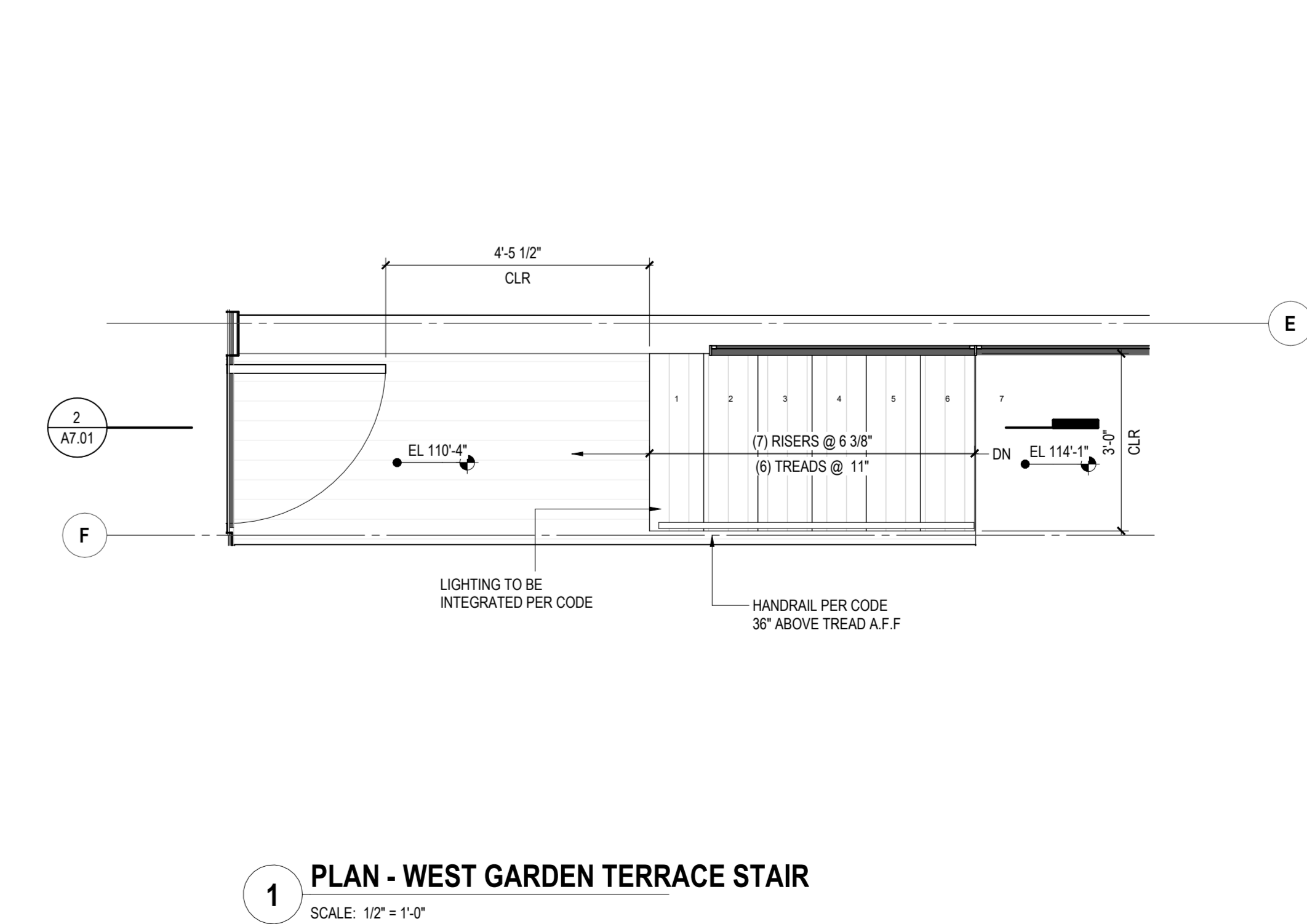
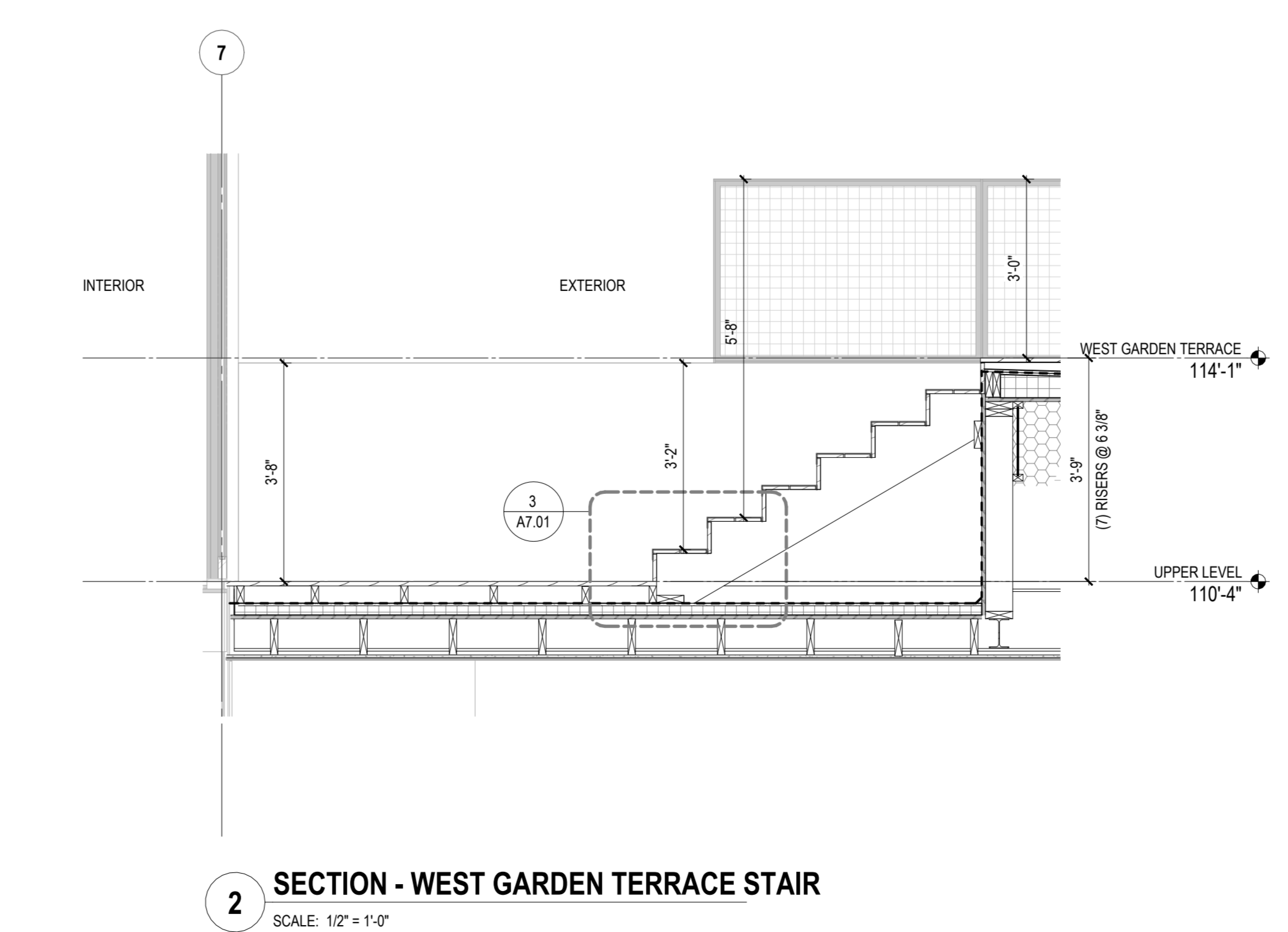
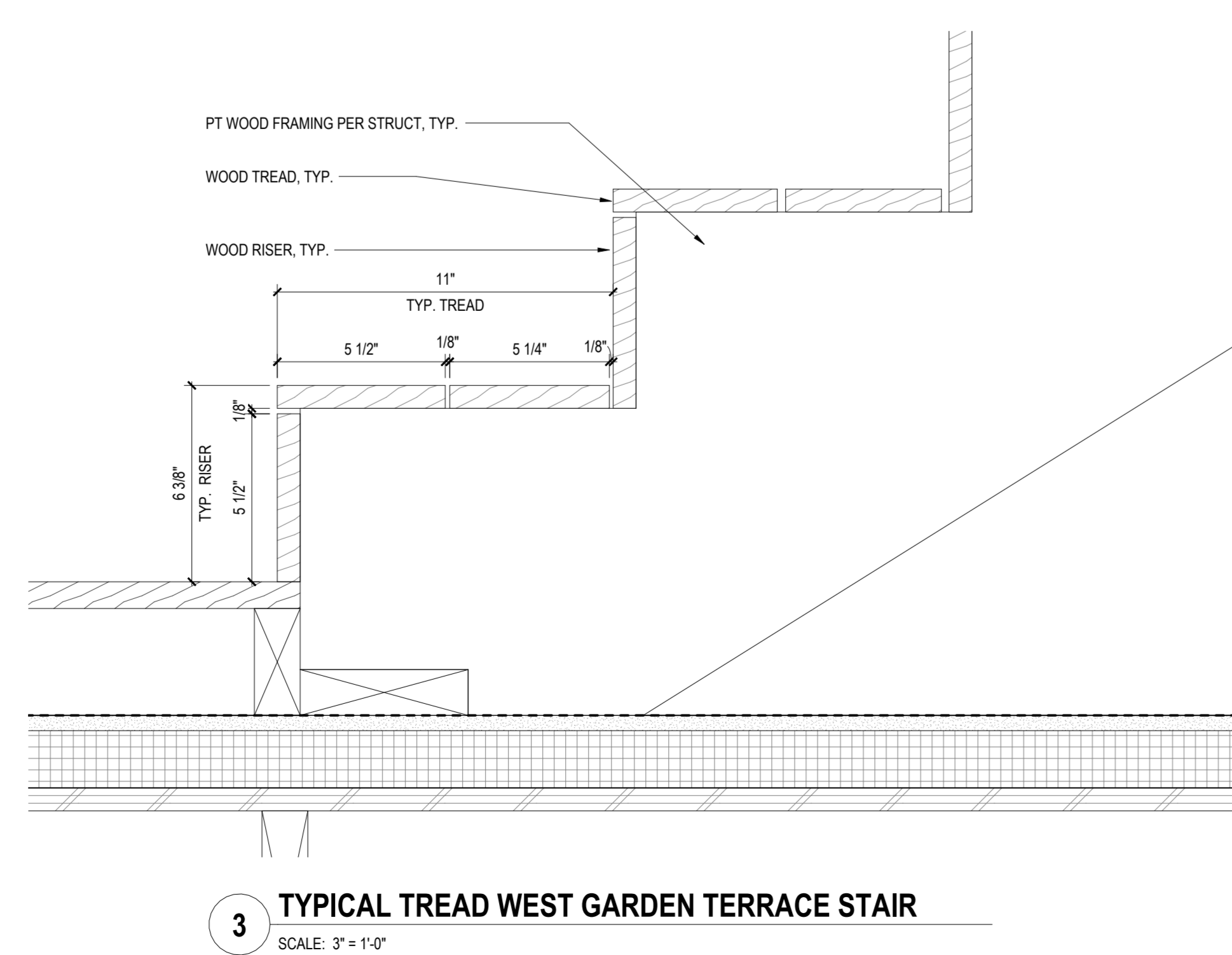
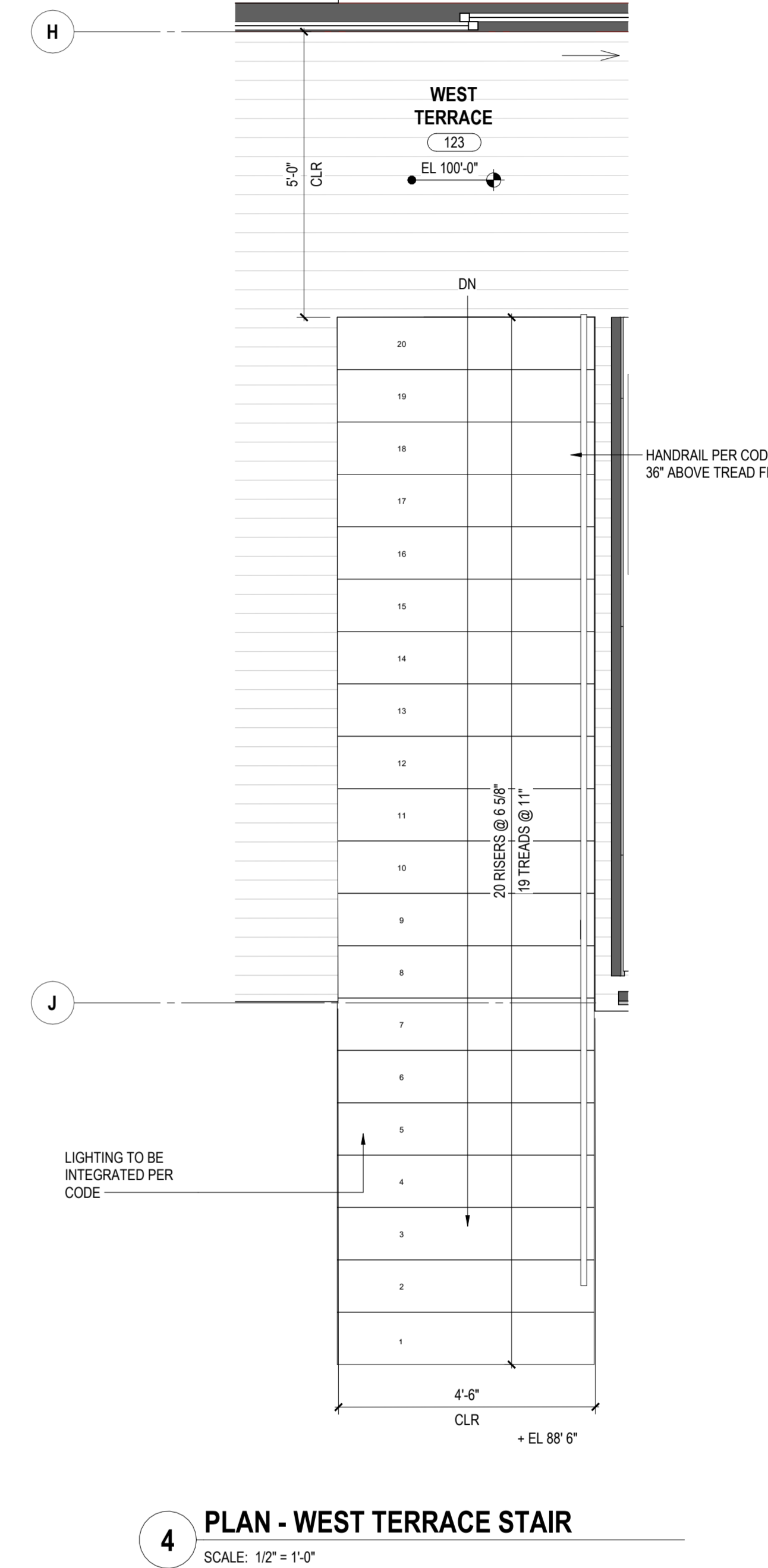
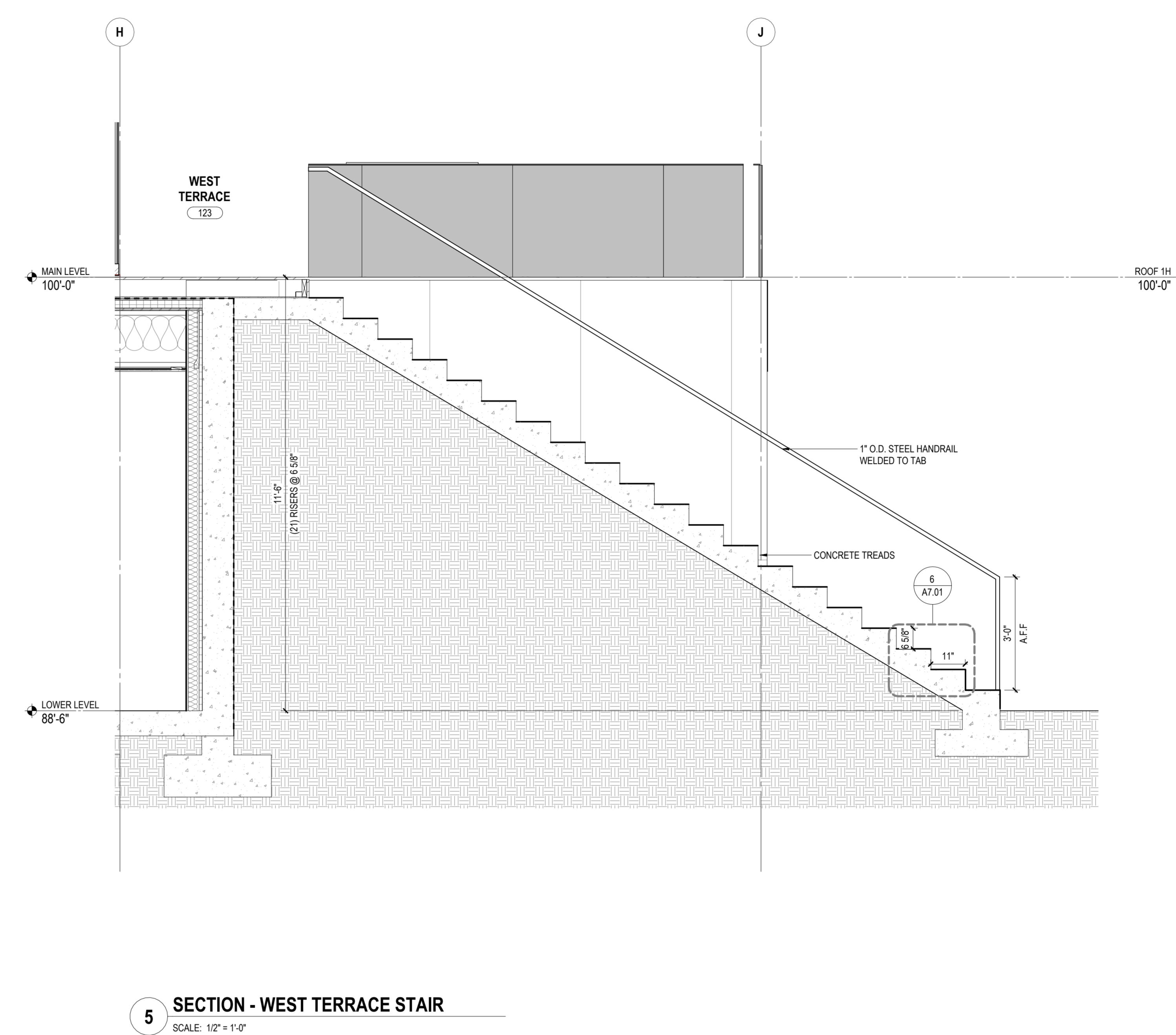
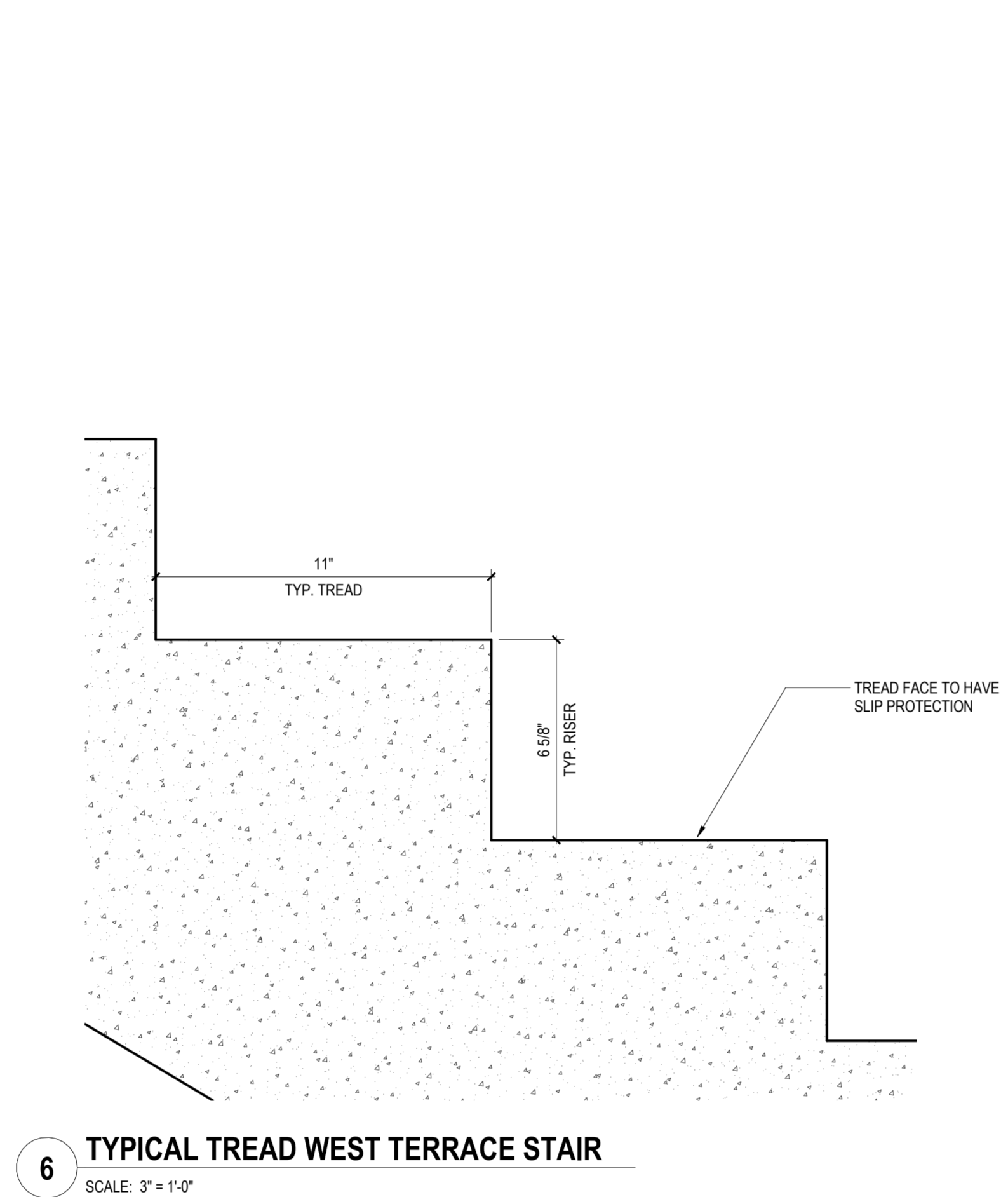

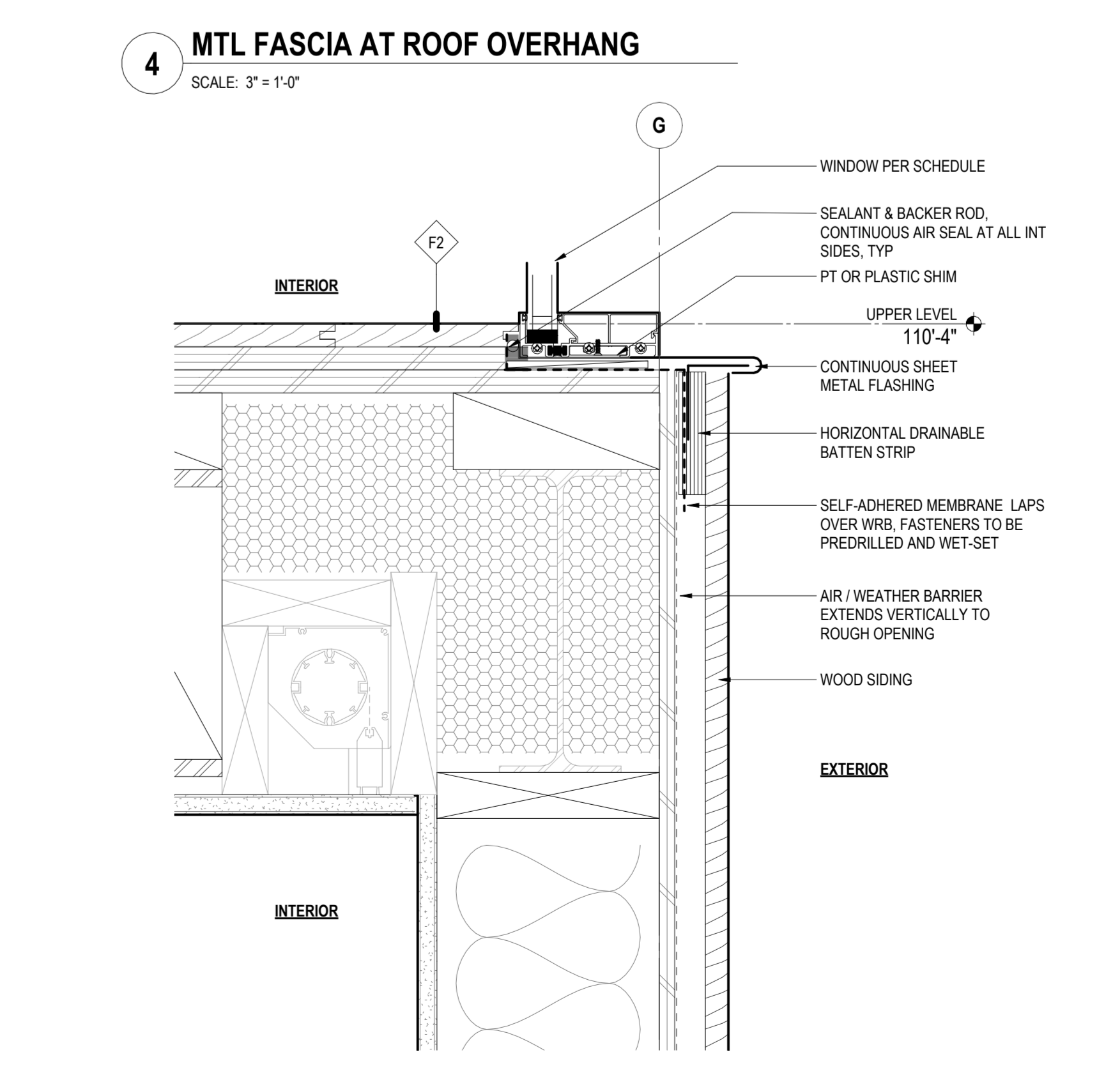
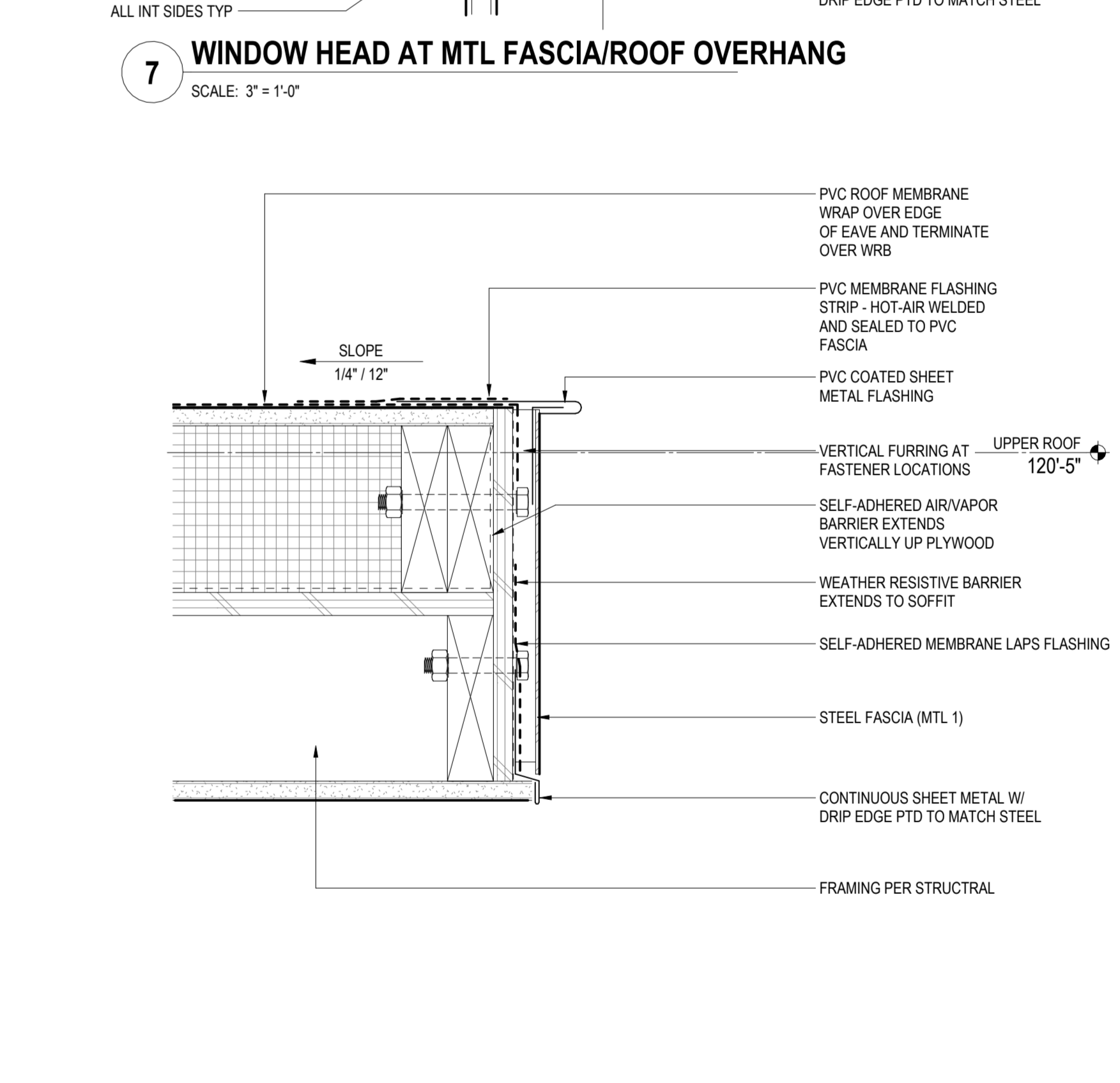
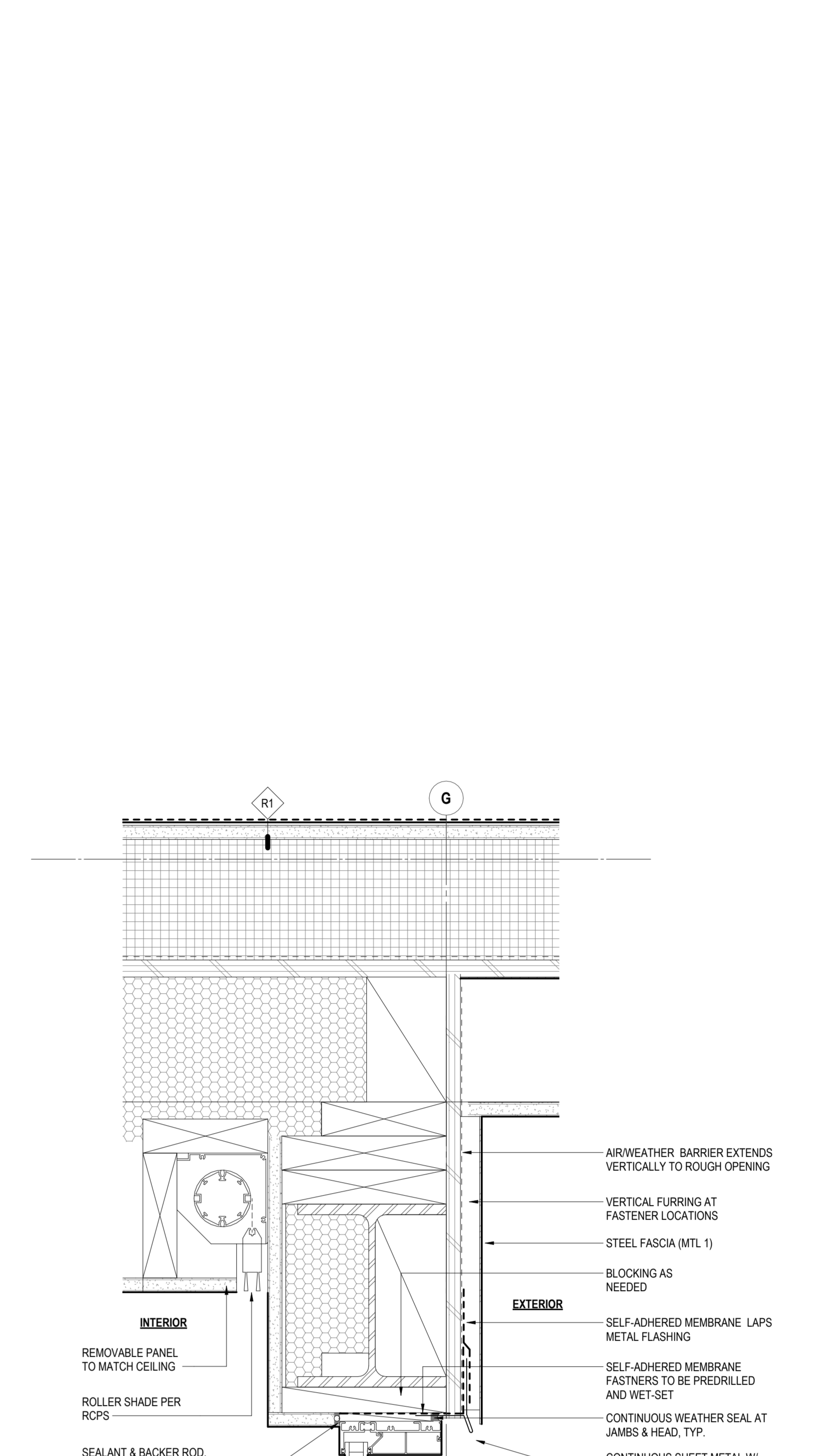
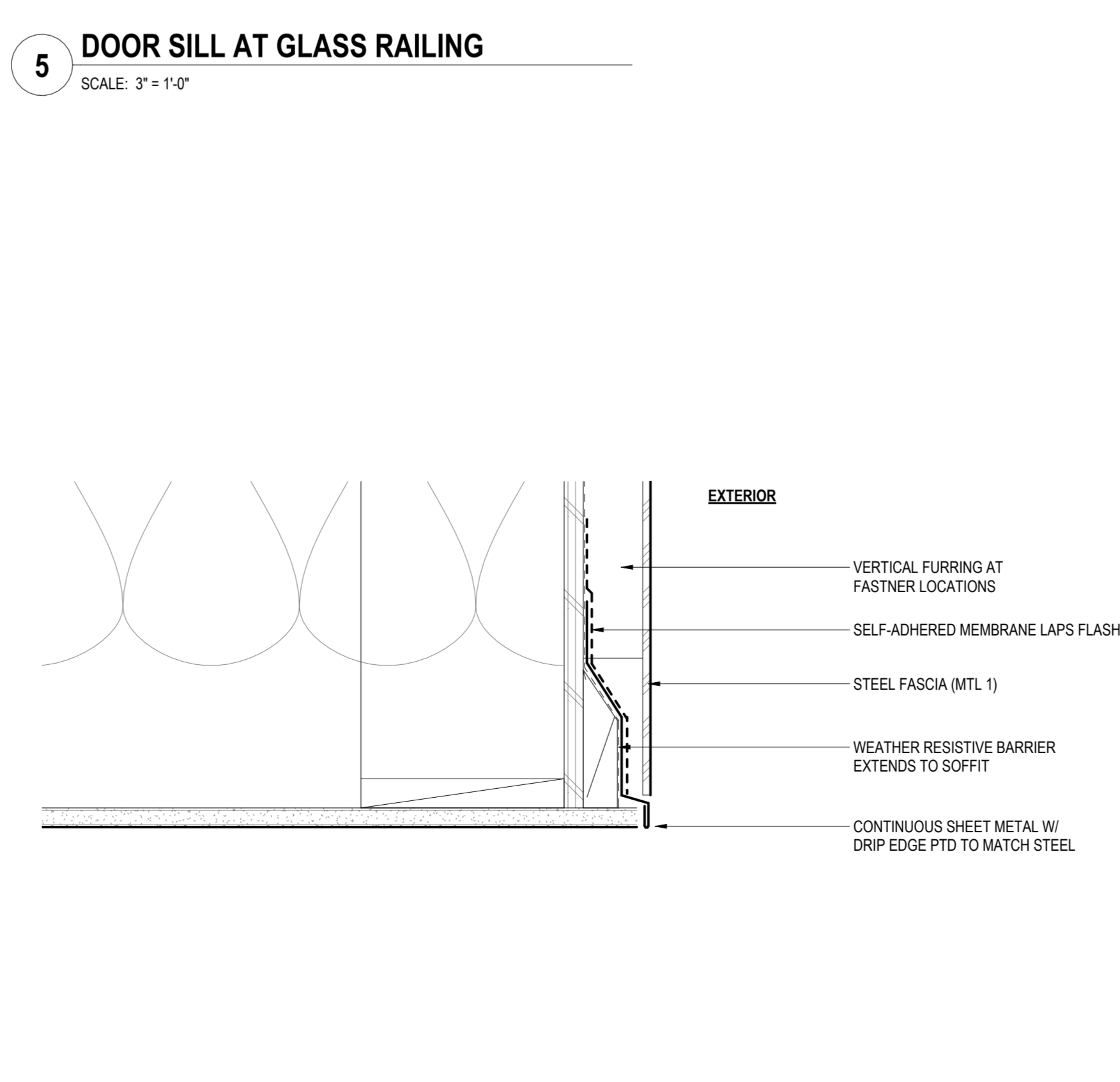
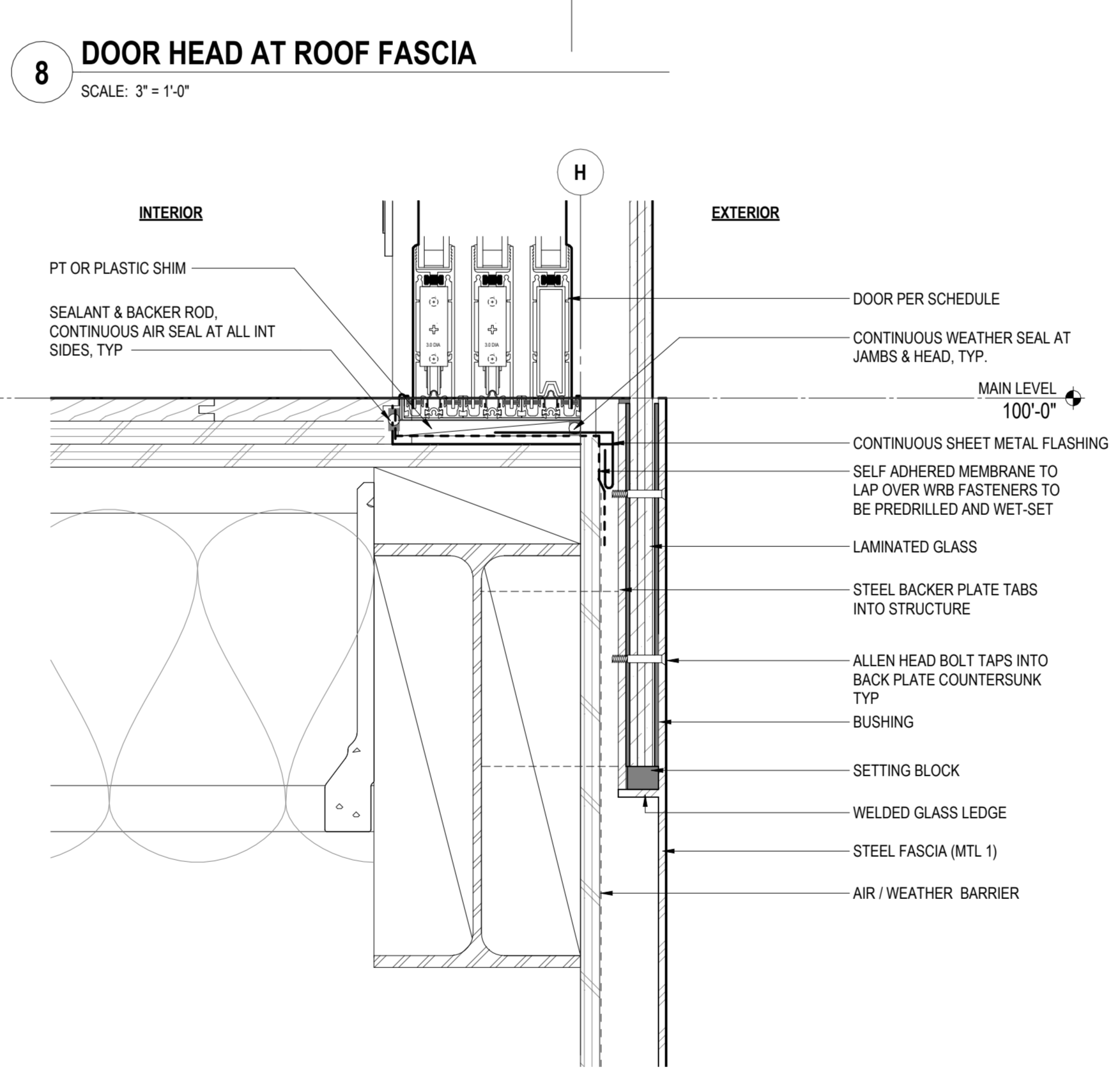
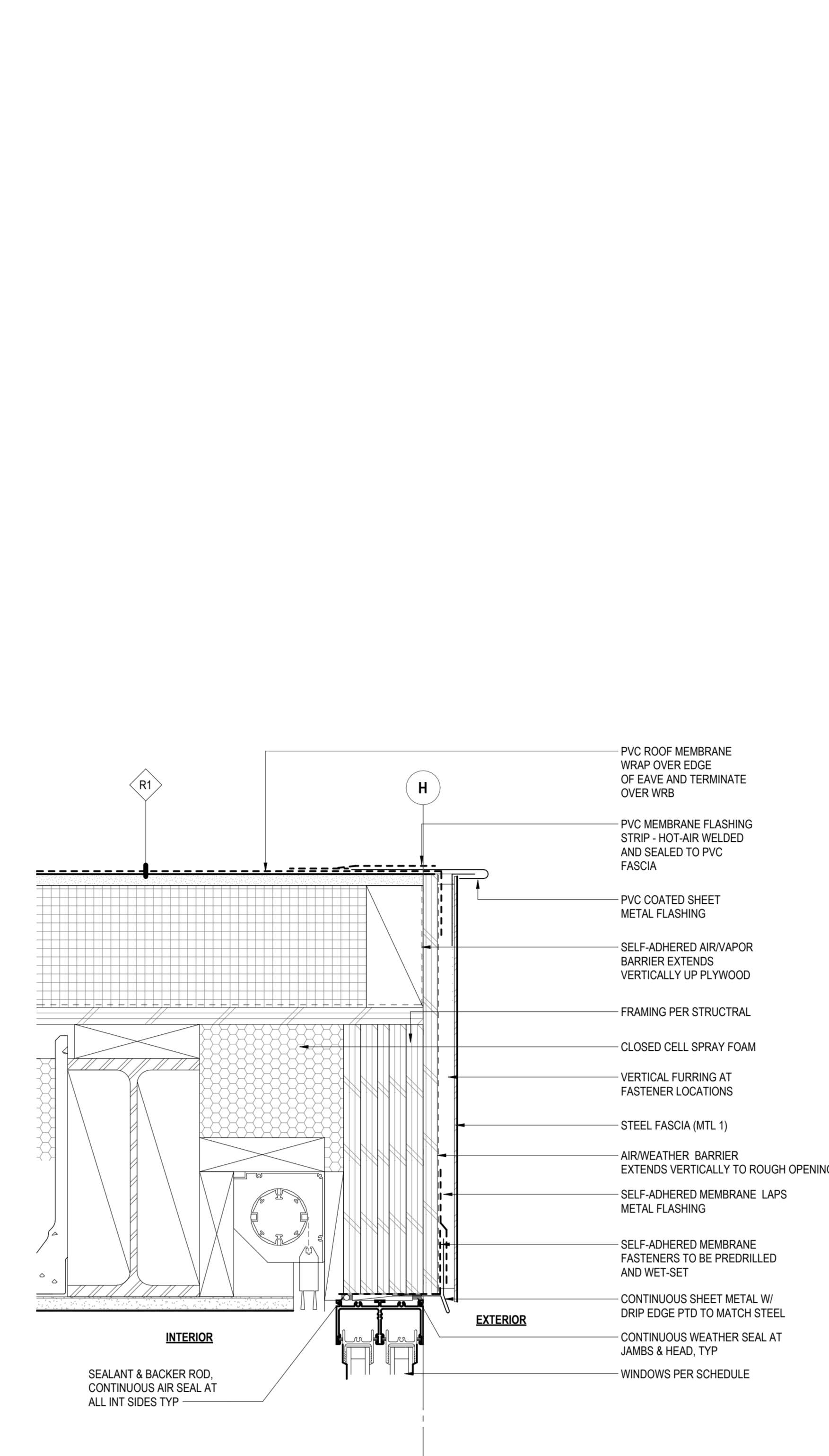
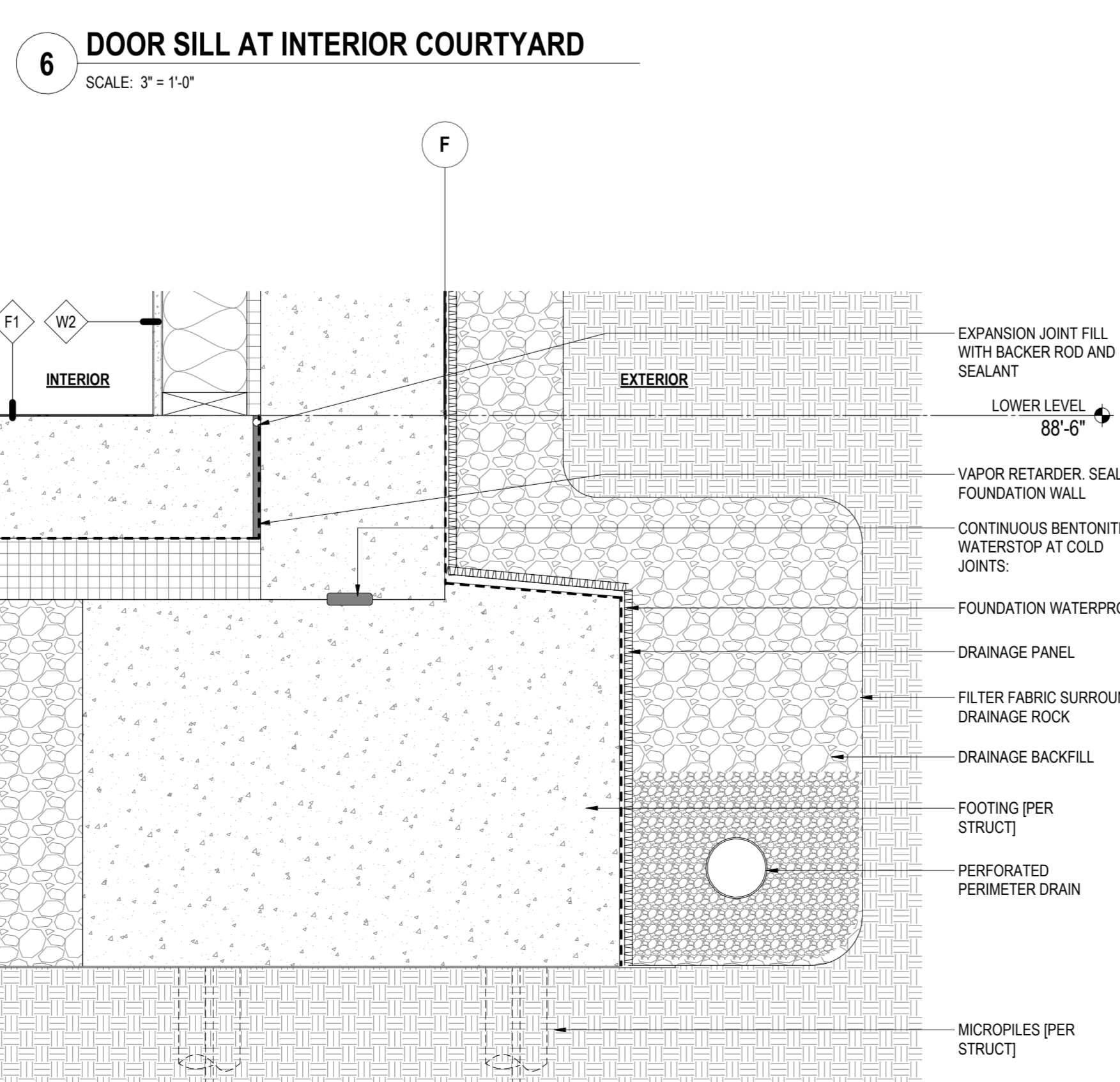
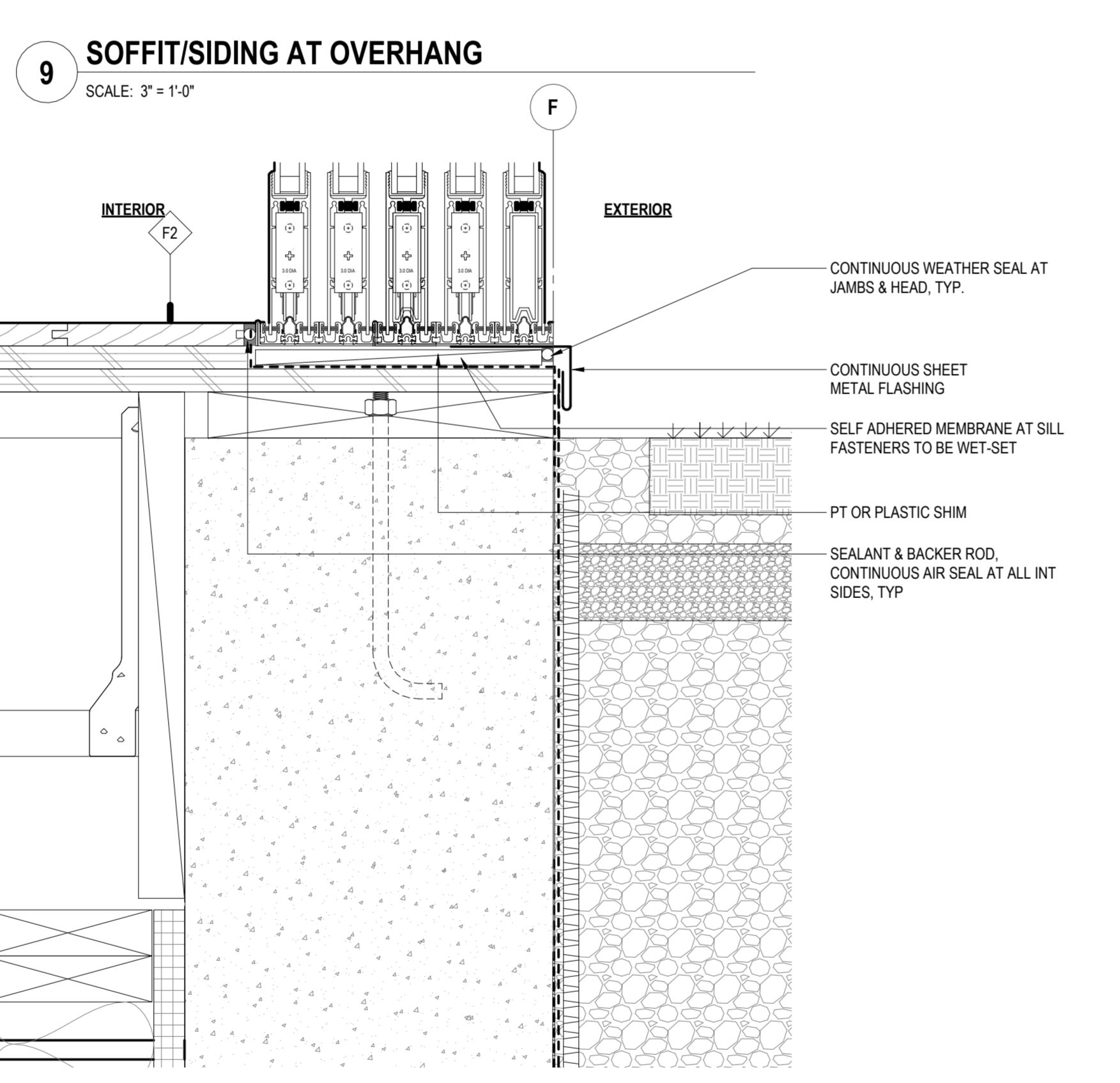
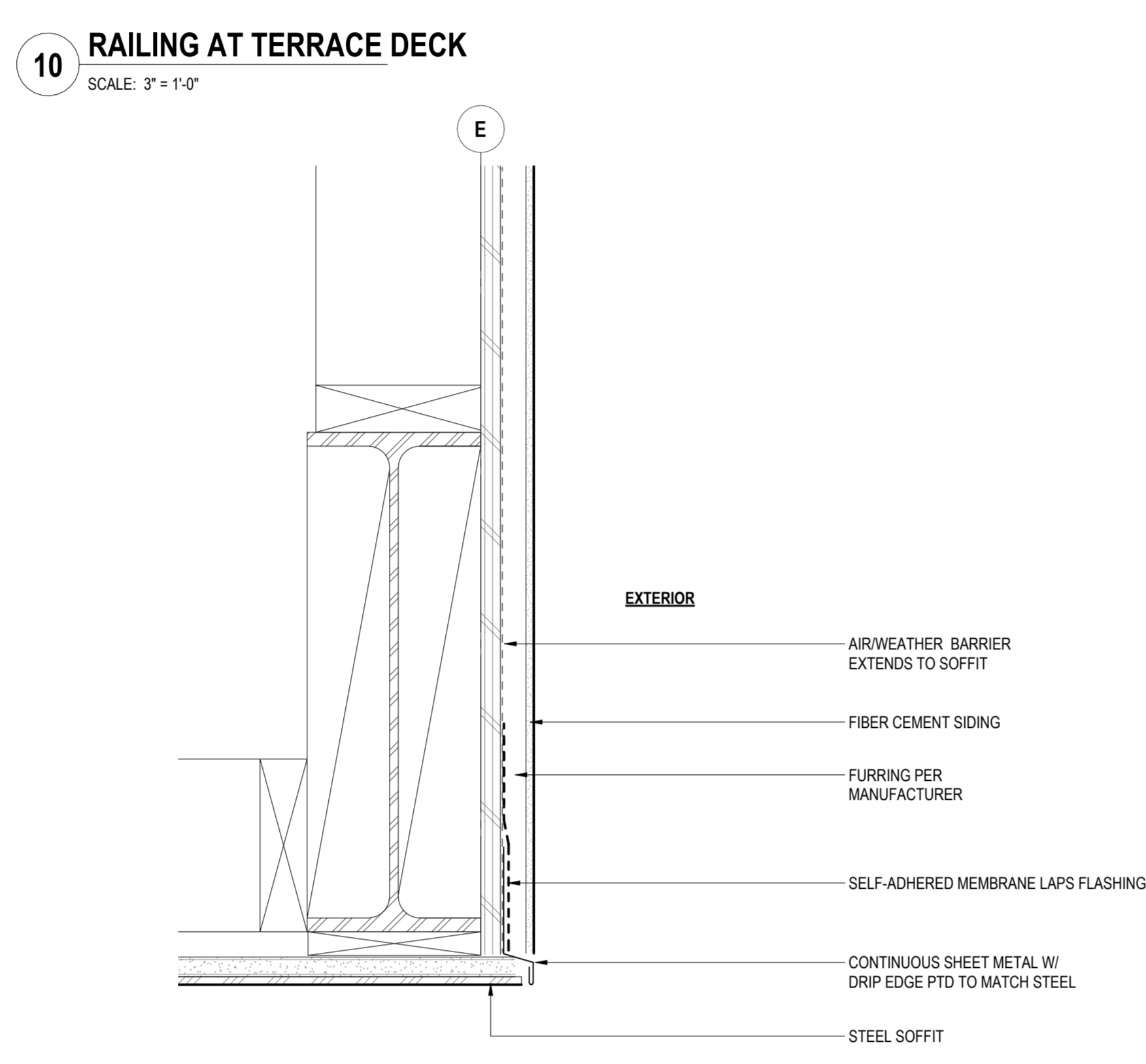
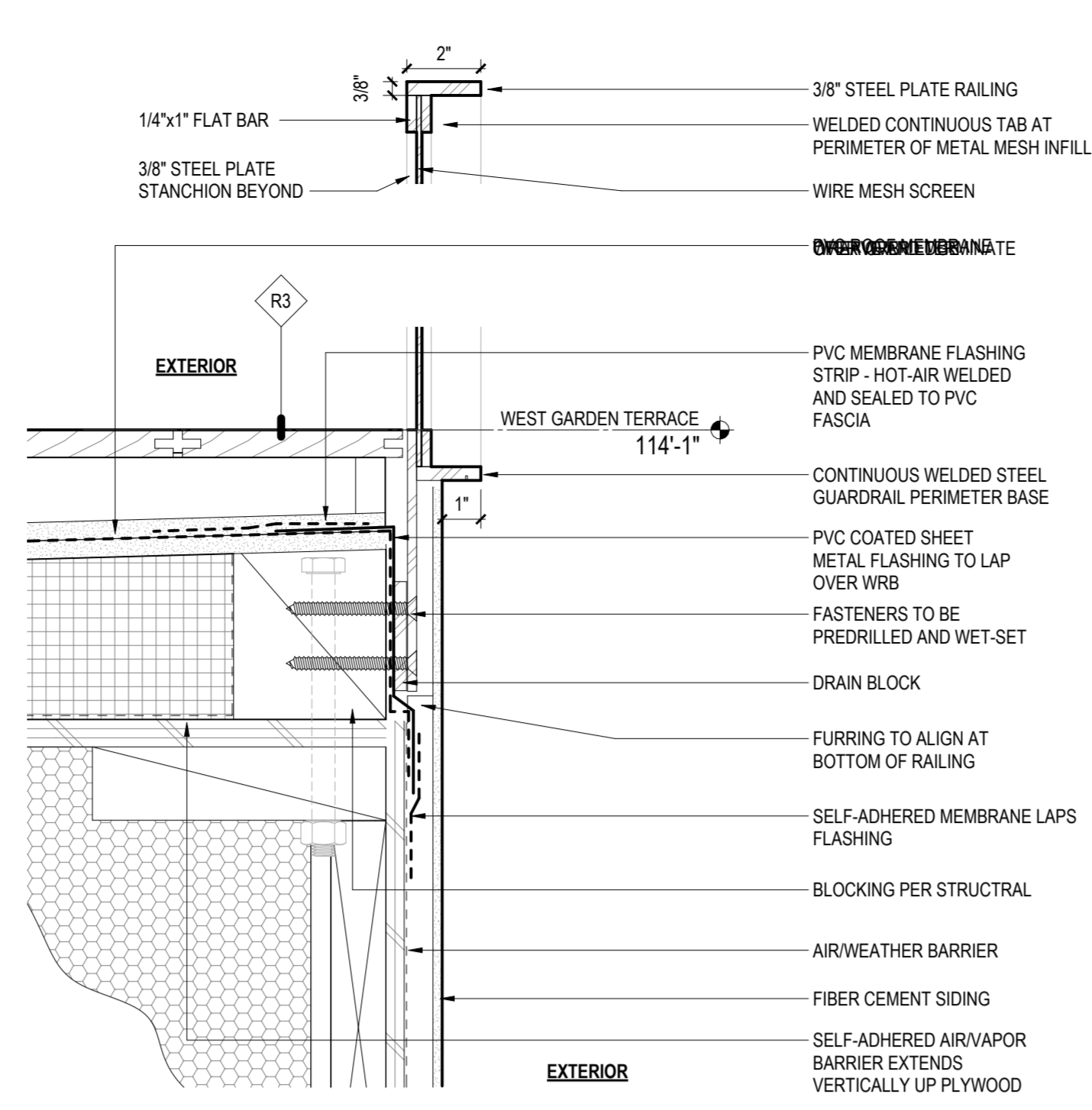

project architect: _____
project manager: _____
drawn by: _____
checked by: _____
job no.: _____

revisions:

no.: _____ date: _____ description: _____

PERMIT SET
09/08/2023

EXTERIOR DETAILS TYPICAL

sheet: **A8.00**

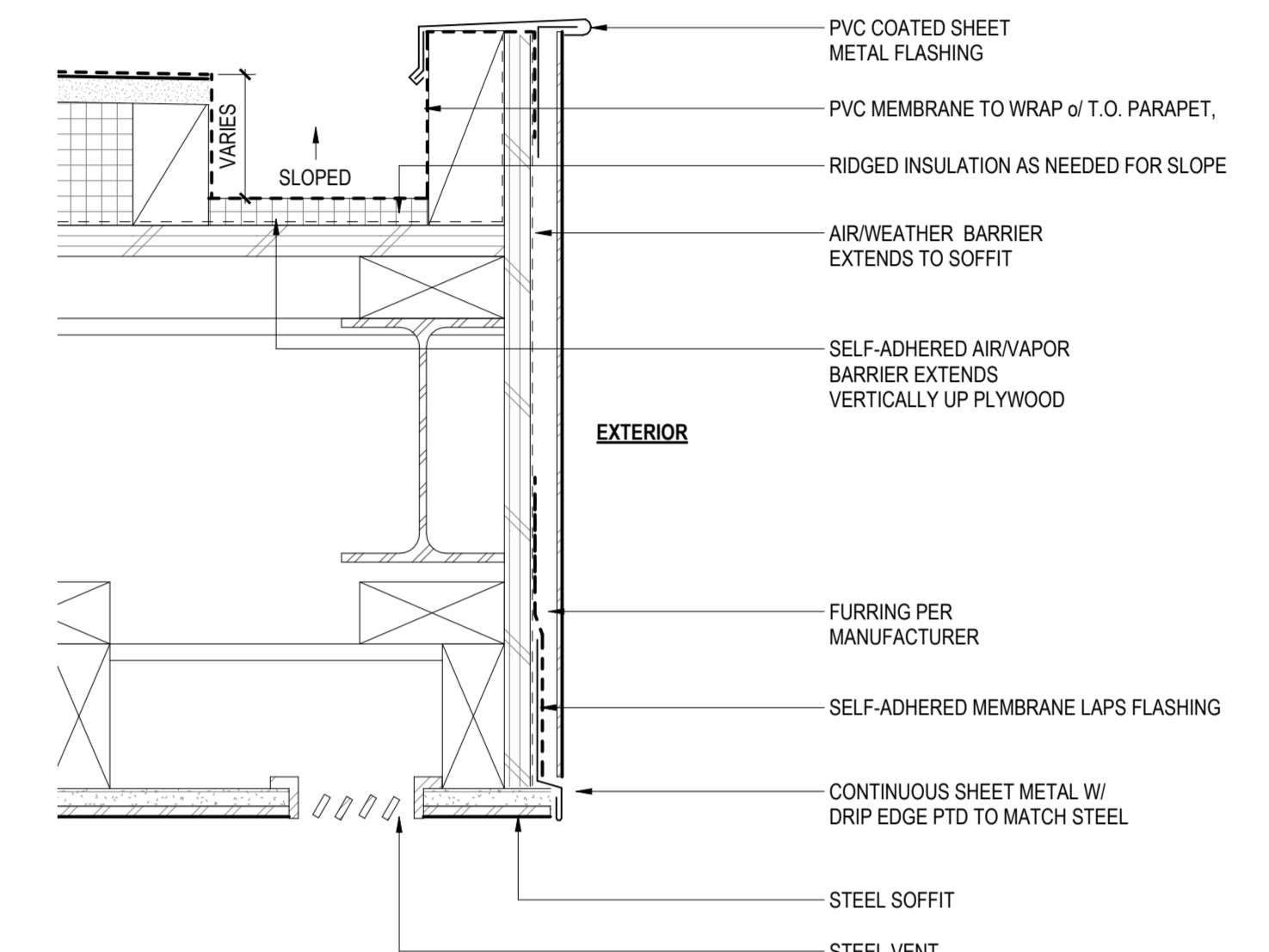
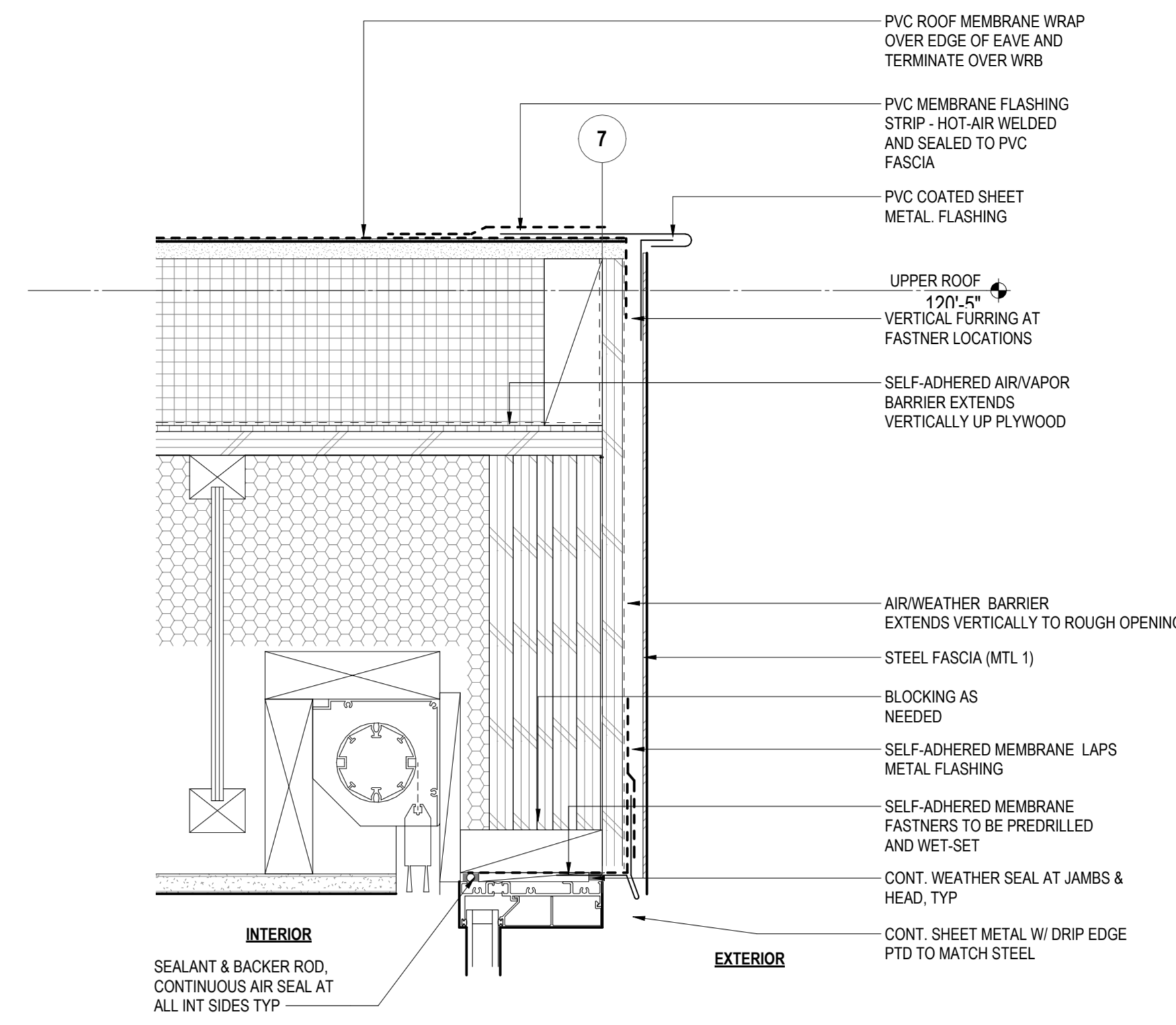
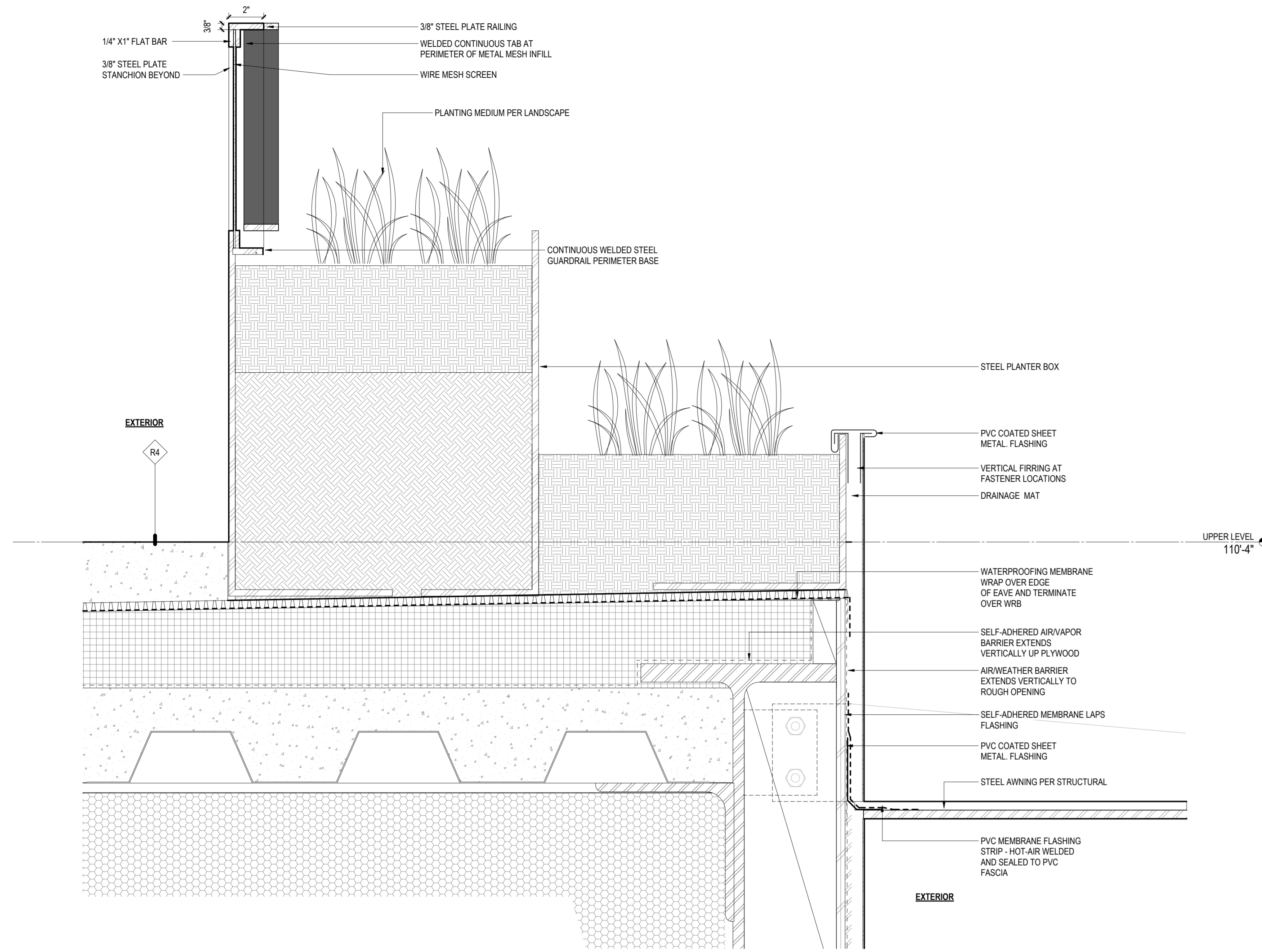

10 GARAGE ROOF AT PLANTER
SCALE: 3" = 1'-0"

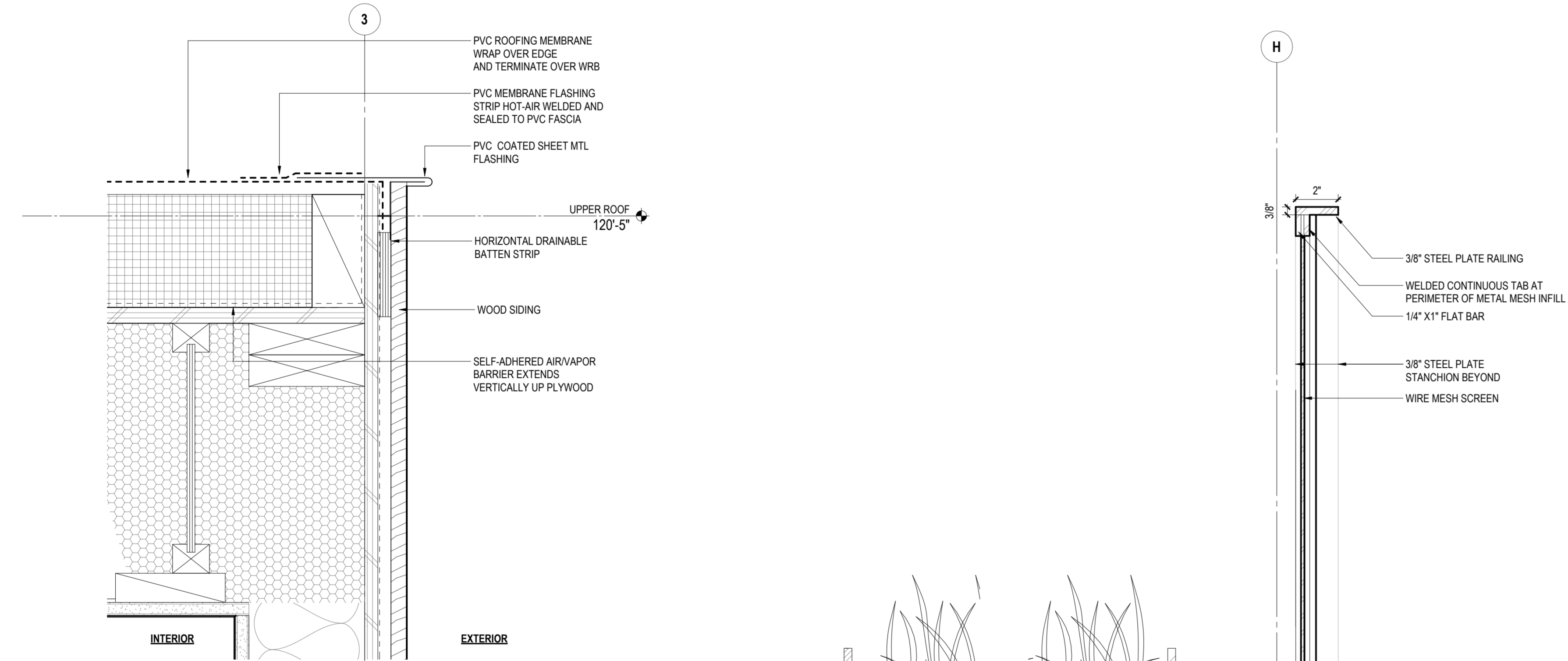

9 WINDOW HEAD AT ROOF FASCIA
SCALE: 3" = 1'-0"

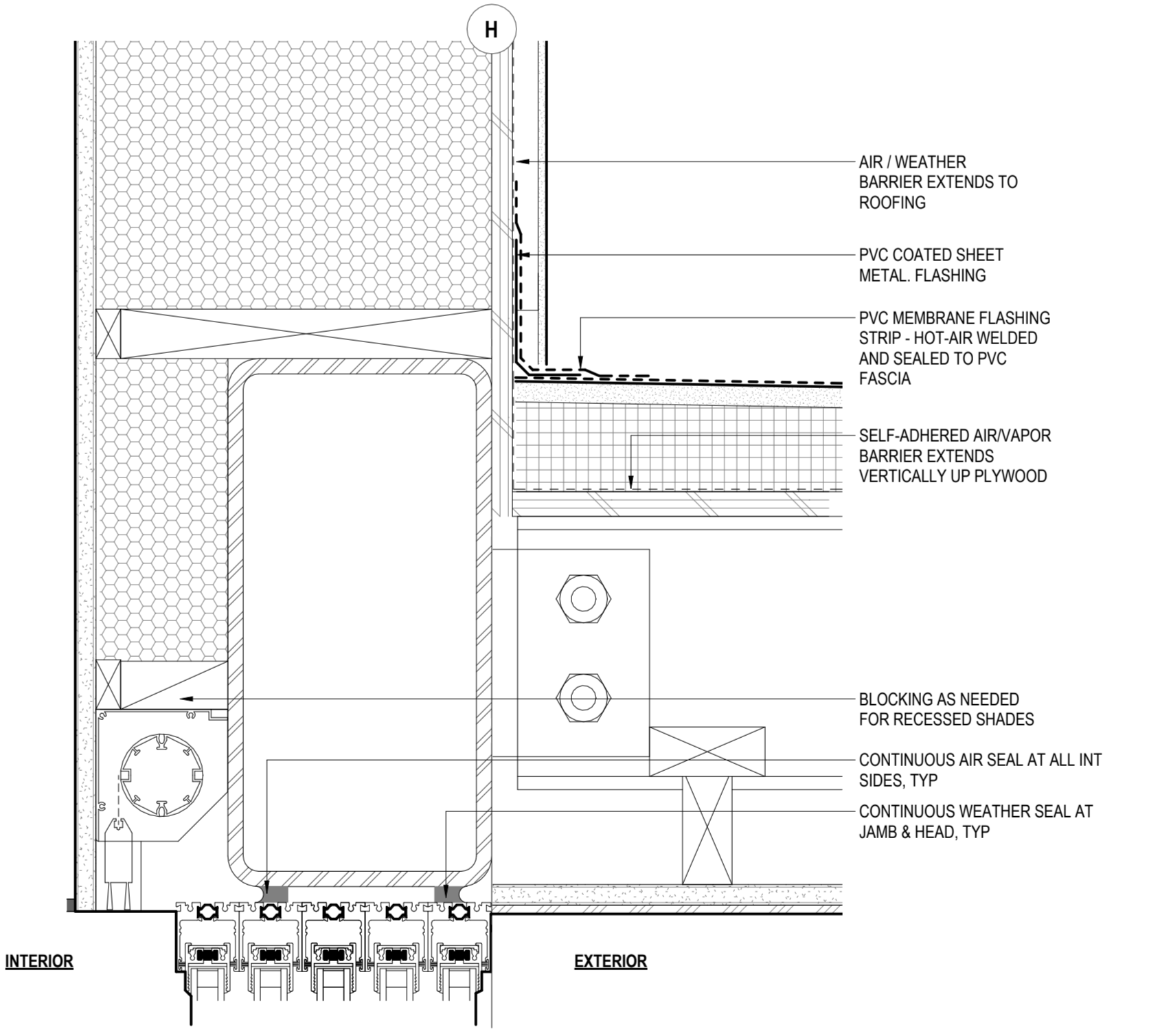

8 MTL FASCIA AT WEST OVERHANG
SCALE: 3" = 1'-0"

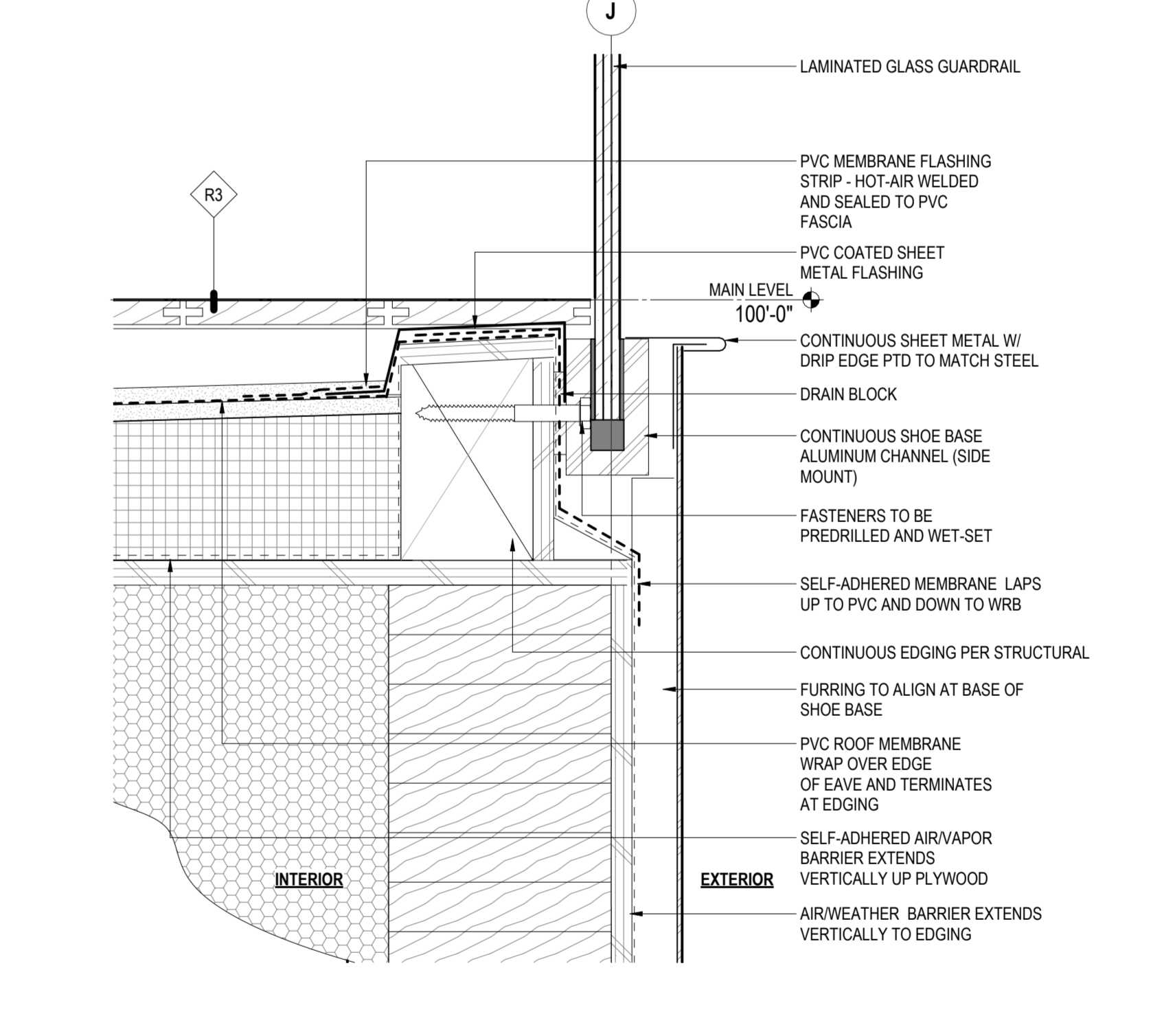

7 ROOF EDGE AT WOOD SIDING
SCALE: 3" = 1'-0"

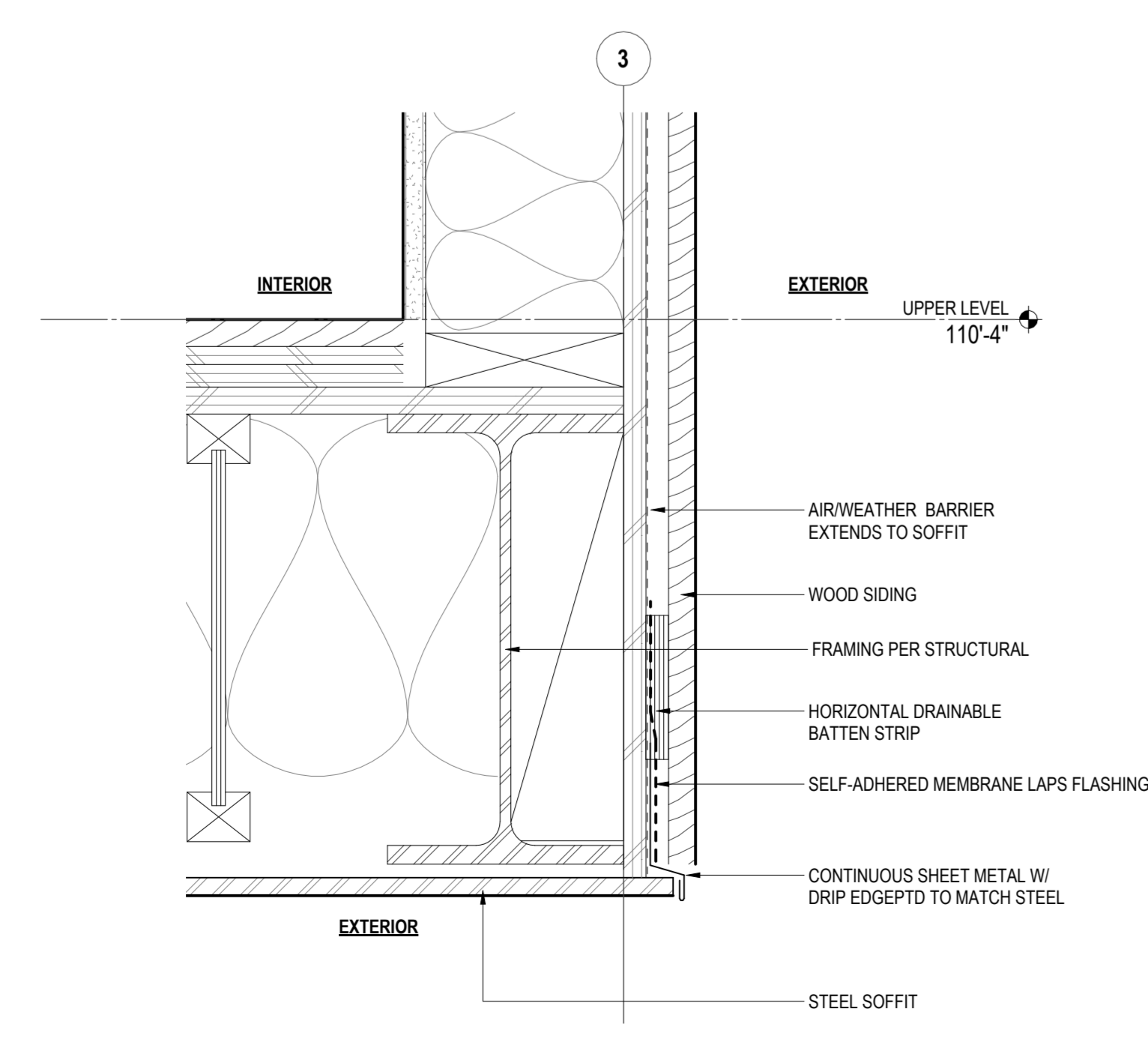

6 DOOR HEAD AT WEST OVERHANG
SCALE: 3" = 1'-0"

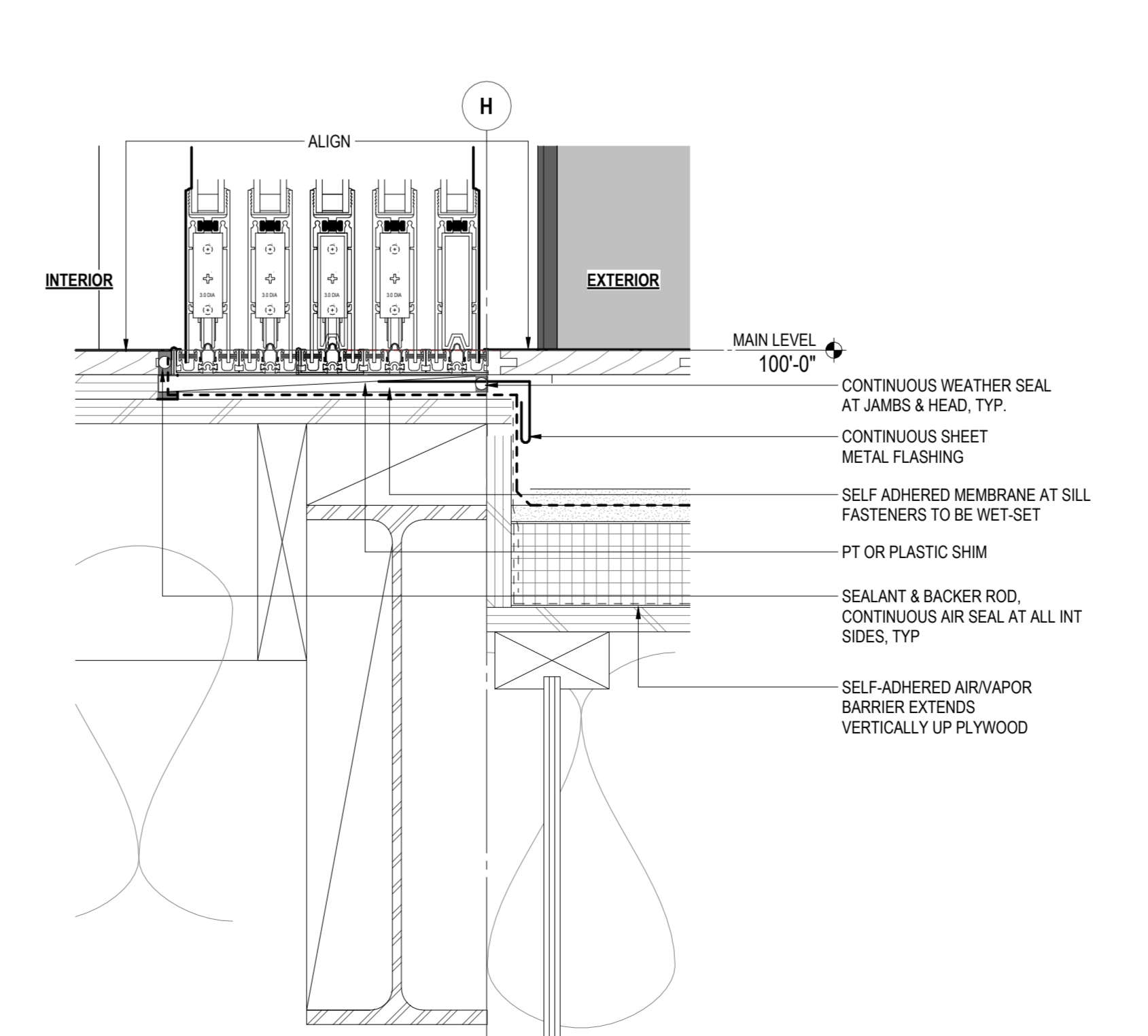

5 RAILING AT WEST TERRACE
SCALE: 3" = 1'-0"

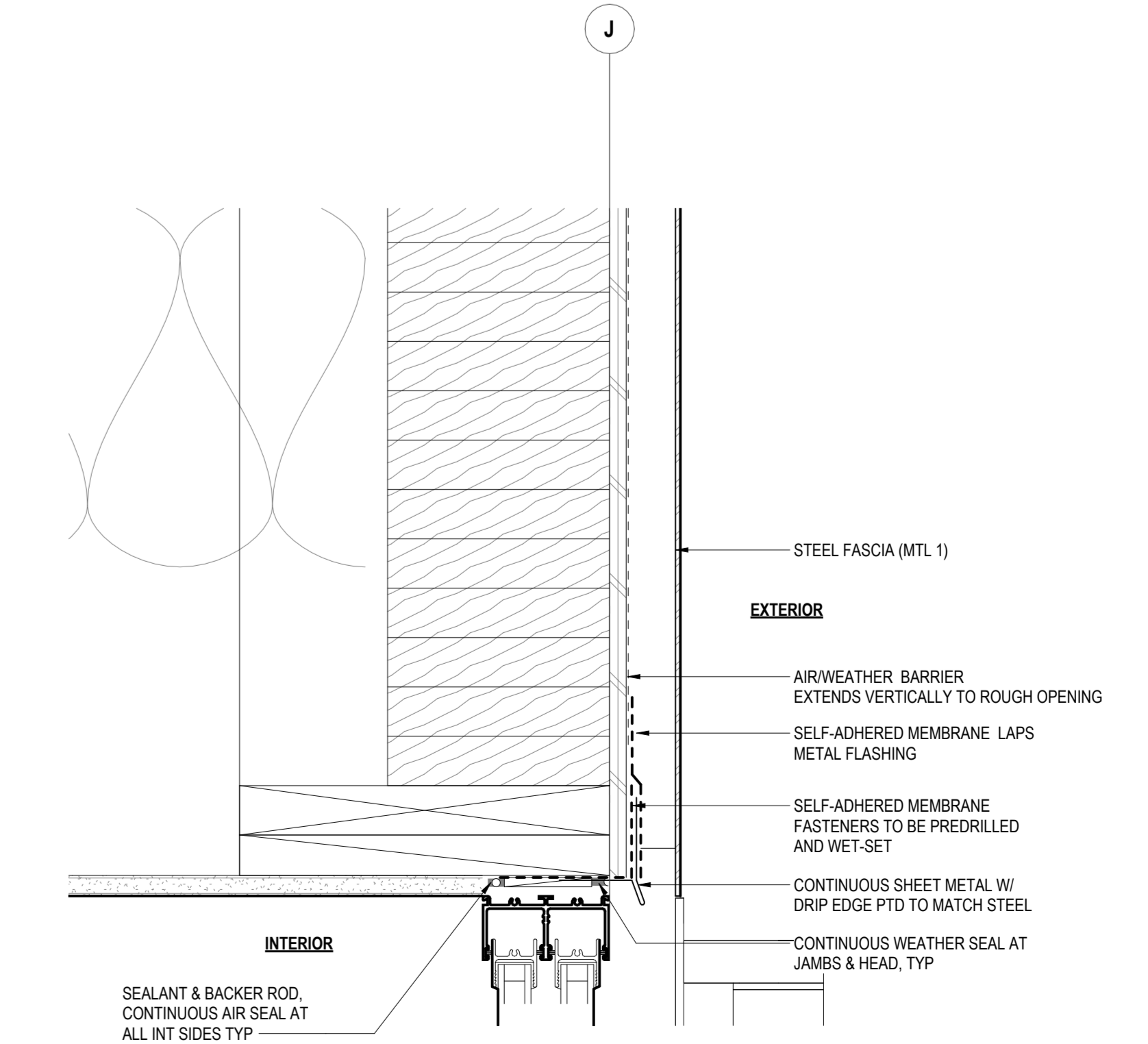

4 SOFFIT AT GARAGE OVERHANG
SCALE: 3" = 1'-0"



3 RAILING AT TERRACE DECK/PLANTER
SCALE: 3" = 1'-0"



2 DOOR SILL AT WEST TERRACE
SCALE: 3" = 1'-0"



1 DOOR HEAD AT STUDIO MTL FASCIA
SCALE: 3" = 1'-0"



project architect: _____
 project manager: _____
 drawn by: _____
 checked by: _____
 job no.: _____

revisions:

NO.	DATE	DESCRIPTION

no.: _____ date: _____ description: _____
PERMIT SET
 09/08/2023
 950: _____
EXTERIOR DETAILS TYPICAL

sheet: **A8.01**

STRUCTURAL NOTES

DESIGN LOADS

ALL DESIGN AND CONSTRUCTION SHALL CONFORM TO THE REQUIREMENTS OF THE INTERNATIONAL BUILDING CODE (IBC), 2018 EDITION, AS AMENDED BY THE CITY OF MERCER ISLAND.

LIVE LOADS

IN ADDITION TO THE DEAD LOADS, THE FOLLOWING FLOOR LIVE LOADS WERE USED FOR DESIGN. LIVE LOAD REDUCTION IS PER IBC SECTION 1607.11.

RECREATIONAL FLOOR	40 PSF	REDUCIBLE UNREDUCIBLE	
		T	X
EXTERIOR BALCONIES, DECKS	1.5 TIMES THE LIVE LOAD FOR THE AREA SERVED, NOT REQUIRED TO EXCEED 100 PSF		

REFER TO TABLE 1607.1 IN THE IBC FOR RELEVANT CONCENTRATED LIVE LOADS.

PHOTOVOLTAIC PANEL SYSTEM ROOF DEAD LOAD
ROOF SUPERIMPOSED DEAD LOAD INCLUDES AN ALLOWANCE OF 3 PSF TO ACCOMMODATE ROOF/TOP-MOUNTED PHOTOVOLTAIC PANEL AND RACK SUPPORT SYSTEMS.

ROOF SNOW LOAD
THE ROOF SNOW LOAD IS DETERMINED USING CHAPTER 7 OF ASCE 7 IN ACCORDANCE WITH IBC SECTION 1609 AND WITH THE FOLLOWING FACTORS:

MINIMUM DESIGN LOAD 25 PSF WITHOUT DRIFT	
$P_f = 15 \text{ PSF}$	$C_s = 1.0$
$L_f = 1.0$	$C_e = 0.9$
$P_f = 11.3 \text{ PSF}$	

RAIN LOADS
RAIN LOADS ARE DETERMINED USING CHAPTER 8 OF ASCE 7 IN ACCORDANCE WITH IBC SECTION 1611 WITH THE FOLLOWING FACTORS:

$I = 1$ HOUR

THE SEISMIC FORCE-RESISTING SYSTEM (SFRS) USED TO RESIST EARTHQUAKE AND WIND LOADS IS COMPRISED OF SHEATHED WOOD LIGHT FRAMED WALL DESIGNATED IN ACCORDANCE WITH THE PROVISIONS OF ANSI/AWC 2018 SPDW'S. EARTHQUAKE DESIGN IS BASED ON THE WITH THE FOLLOWING FACTORS:

SITE CLASS 3	$h = 35 \text{ FT}$
RISK CATEGORY II	$T = 0.3 \text{ SECONDS}$
SEISMIC DESIGN CATEGORY D	$R = 6.5$
$S_s = 1.0$	$D = 3$
$S_1 = 1.435 \text{ g}$	$C_u = 1.47$
$S_2 = 0.499 \text{ g}$	$C_v = 0.14$
$S_3 = 0.8 \text{ g}$	$V = 0.33$
$S_4 = 0.9 \text{ g}$	$V = 0.33$
$T_c = 6 \text{ SECONDS}$	

THE SEISMIC FORCE-RESISTING SYSTEM IS COMPRISED OF THE STRUCTURAL WOOD MEMBERS AND CONNECTIONS IDENTIFIED IN PLAN.

WIND LOADS
WIND LOAD IS DETERMINED USING CHAPTERS 26-31 OF ASCE 7 IN ACCORDANCE WITH IBC SECTION 1609 WITH THE FOLLOWING FACTORS:

RISK CATEGORY II	$K_z = 1.0$
EXPOSURE CATEGORY B	$G_w = 0.18$
$V = 110 \text{ MPH}$	
$V_{ref} = 85 \text{ MPH}$	

DESIGN WIND PRESSURES FOR DETERMINING FORCES ON COMPONENTS AND CLADDING SHALL BE DETERMINED USING CHAPTER 30 OF ASCE 7 IN ACCORDANCE WITH IBC SECTION 1609 BY THE WASHINGTON STATE REGISTERED PROFESSIONAL ENGINEER WHO IS RESPONSIBLE FOR THE DESIGN OF SUCH ELEMENTS, UNLESS NOTED OTHERWISE ON THE DRAWINGS.

SOIL LOADS	
6.0 PIPE WALL CAPACITY	15 TONS DOWNWARD
RETAINING WALLS	55 PCF EQUIVALENT FLUID PRESSURE)
	UNRESTRAINED
	35 PCF EQUIVALENT FLUID PRESSURE)

GENERAL NOTES

SUBMITTALS
SHOP DRAWINGS SHALL BE SUBMITTED TO THE ARCHITECT PRIOR TO ANY FABRICATION OR CONSTRUCTION FOR ALL STRUCTURAL ITEMS, INCLUDING THE FOLLOWING: CONCRETE OR MASONRY REINFORCEMENT, PRECAST OR PRESTRESSED CONCRETE ITEMS, EMBEDDED STEEL ITEMS, STRUCTURAL STEEL, STEEL JOISTS, STEEL DECK, SHEAR STUD LAYOUT, METAL GRATING, GLUED-LAMINATED MEMBERS, CLADDING PANELS AND STAIRS.

IF THE SHOP DRAWINGS DIFFER FROM OR ADD TO THE DESIGN OF THE STRUCTURAL DRAWINGS, THEY SHALL BEAR THE SEAL AND SIGNATURE OF THE WASHINGTON STATE REGISTERED PROFESSIONAL ENGINEER WHO IS RESPONSIBLE FOR THE DESIGN.

DEFERRED SUBMITTALS
PER IBC SECTION 107.3.4.1, DRAWINGS AND CALCULATIONS FOR THE DESIGN AND FABRICATION OF ITEMS THAT ARE DESIGNED BY OTHERS SHALL BEAR THE SEAL AND SIGNATURE OF THE WASHINGTON STATE REGISTERED PROFESSIONAL ENGINEER WHO IS RESPONSIBLE FOR THE DESIGN AND SHALL BE SUBMITTED TO THE ARCHITECT AND THE BUILDING DEPARTMENT FOR REVIEW PRIOR TO FABRICATION. DEFERRED SUBMITTALS INCLUDE, BUT ARE NOT LIMITED TO THE FOLLOWING:

- EXTERIOR CLADDING SYSTEMS
- SKYLIGHT FRAMING
- EQUIPMENT ANCHORAGE
- SEISMIC DESIGN OF NONSTRUCTURAL COMPONENTS
- HELICAL FOUNDATION ANCHORS
- ALTERNATE ANCHORS (WHEN ALTERNATE ANCHORS ARE PROPOSED)

NONSTRUCTURAL COMPONENTS
CONCRETE DETAILING AND ANCHORAGE OF ALL NONSTRUCTURAL COMPONENTS SHALL BE IN ACCORDANCE WITH IBC SECTION 1613, ASCE 7 CHAPTER 13, AND THE PROJECT SPECIFICATIONS. NONSTRUCTURAL COMPONENTS DESIGNED BY OTHERS SHALL NOT INDUCE TORSIONAL LOADING INTO SUPPORTING STRUCTURAL MEMBERS WITHOUT ADDITIONAL BRACING OF THOSE MEMBERS TO ELIMINATE TORSIONAL FORCES. TORSIONAL BRACING SHALL BE DESIGNED BY THE NONSTRUCTURAL COMPONENT DESIGNER AND APPROVED BY THE ENGINEER.

DESIGN, DETAILING AND CONSTRUCTION OF ALL NONSTRUCTURAL COMPONENTS WHICH ATTACH TO STRUCTURE SHALL ACCOMMODATE CONSTRUCTION TOLERANCES AS ESTABLISHED BY THE STRUCTURAL SPECIFICATIONS. ANY NONSTRUCTURAL COMPONENTS WHICH ATTACH TO MORE THAN ONE LEVEL OF THE STRUCTURE SHALL ALSO ACCOMMODATE THE FOLLOWING RELATIVE MOVEMENTS BETWEEN LEVELS WITHOUT DAMAGE TO THE NONSTRUCTURAL COMPONENTS:

VERTICAL DEFLECTION OF $\pm 1/2$ INCH DUE TO VARIABLE LIVE LOADS
ELASTIC STORY DRIFT PER "STORY DRIFT" SECTION ABOVE

IN ADDITION, NONSTRUCTURAL COMPONENTS ATTACHED TO MORE THAN ONE LEVEL SHALL ACCOMMODATE AN INELASTIC STORY DRIFT PER "STORY DRIFT" SECTION ABOVE WITHOUT CREATING A LIFE SAFETY HAZARD.

CLADDING
CLADDING DESIGNED BY OTHERS SHALL BE SUPPORTED AT EACH STORY TO BE CONSISTENT WITH THE DESIGN OF THE LONG STRUCTURE. CLADDING DESIGNED BY OTHERS SHALL NOT INDUCE TORSIONAL LOADING INTO SUPPORTING STRUCTURAL MEMBERS WITHOUT ADDITIONAL BRACING OF THOSE MEMBERS TO ELIMINATE TORSIONAL FORCES, UNLESS OTHERWISE APPROVED BY THE ARCHITECT. TORSIONAL BRACING SHALL BE DESIGNED BY THE CLADDING DESIGNER AND APPROVED BY THE ENGINEER.

INSPECTION
SPECIAL INSPECTION PER IBC CHAPTER 17 SHALL BE PERFORMED BY AN APPROVED TESTING AGENCY AS INDICATED IN THE STATEMENT OF SPECIAL INSPECTIONS AND TESTING. ALL PREPARED SOIL-BEARING SURFACES SHALL BE INSPECTED BY THE GEOTECHNICAL ENGINEER PRIOR TO PLACEMENT OF REINFORCING STEEL. SOIL COMPACTION SHALL BE SUPERVISED BY AN APPROVED TESTING AGENCY OR GEOTECHNICAL ENGINEER.

SPECIAL CONDITIONS
CONTRACTOR SHALL VERIFY ALL LEVELS, DIMENSIONS, AND EXISTING CONDITIONS IN THE FIELD BEFORE PROCEEDING. CONTRACTOR SHALL NOTIFY THE ARCHITECT OF ANY DISCREPANCIES OR FIELD CHANGES PRIOR TO INSTALLATION OR FABRICATION. IN CASE OF DISCREPANCIES BETWEEN THE EXISTING CONDITIONS AND THE DRAWINGS, THE CONTRACTOR SHALL OBTAIN DIRECTION FROM THE ARCHITECT BEFORE PROCEEDING. DIMENSIONS NOTED AS PLUS OR MINUS (±) INDICATE UNIFORM DIMENSIONS AND ARE APPROXIMATE. NOTIFY ARCHITECT IMMEDIATELY OF CONFLICTS OR EXCESSIVE VARIATIONS FROM INDICATED DIMENSIONS. NOTED DIMENSIONS TAKE PRECEDENCE OVER SCALED DIMENSIONS--DO NOT SCALE DRAWINGS. DIMENSIONS OF EXISTING CONDITIONS.

CONTRACTOR SHALL BE RESPONSIBLE FOR ALL SAFETY PRECAUTIONS AND THE METHODS, TECHNIQUES, SEQUENCES OR PROCEDURES REQUIRED TO PERFORM THE WORK.

SOILS
SEE THE GEOTECHNICAL REPORT BY ASSOCIATED EARTH SCIENCES INC., DATED AUGUST 16TH, 2022, FOR MORE COMPLETE INFORMATION. EARTHWORK MATERIAL, BACKFILL AND COMPACTION SHALL BE IN ACCORDANCE WITH THE RECOMMENDATIONS OF THE GEOTECHNICAL ENGINEER. SOILS SHALL BE PLACED BEFORE THE WALLS AND SUPPORTING SLABS ACHIEVE 28 DAY CONCRETE STRENGTH OR THE WALLS ARE TEMPORARILY BRACED. ALL TOP SOILS, DEBRIS AND LOOSE SURFACE SOIL SHALL BE REMOVED FROM BENEATH FILL SUPPORTING CONCRETE SLABS OR PAVING.

MEMBER SPACING
ALL FRAMING MEMBERS SHALL BE EQUALLY SPACED BETWEEN GRID LINES, COLUMNS, AND DIMENSIONED FRAMING UNLESS NOTED OTHERWISE.

PIPE PILES

BIDDER-DESIGNED
PILE SHALL BE A DEFERRED SUBMITTAL PER THE REQUIREMENTS OF THE GENERAL NOTES. PILES SHALL BE DESIGNED FOR THE LOADS INDICATED IN THESE DRAWINGS. PIPE PILES DESIGN CAPACITIES SHALL BE DETERMINED USING THE METHODS IN THE FHWA PIPE PILES DESIGN AND CONSTRUCTION REFERENCE MANUAL, AND THE CONTRACTOR'S EXPERIENCE.

THE CONTRACTOR IS RESPONSIBLE FOR THE DESIGN, INSTALLATION, AND TESTING OF PIPE PILES AND THE DESIGN AND INSTALLATION OF THE PIPE PILES TOP ATTACHMENT TO THE SUPPORTED STRUCTURE. THE CONTRACTOR SHALL SELECT THE PIPE PILE TYPE, SIZE, EMBEDMENT DEPTH, REINFORCEMENT, AND INSTALLATION MEANS AND METHODS TO MEET THE SPECIFIED PERFORMANCE REQUIREMENTS. THE MINIMUM PIPE PILE DIAMETER SHALL NOT BE LESS THAN AS INDICATED IN THESE DRAWINGS.

PIPE PILE LOAD CAPACITIES SHALL BE CONFIRMED BY PROOF TESTING, AND SHALL MEET THE TEST ACCEPTANCE CRITERIA IN THE PROJECT SPECIFICATIONS.

CONCRETE

CONCRETE WORK SHALL CONFORM TO ALL REQUIREMENTS OF IBC CHAPTER 19.

CONCRETE MIXTURES
CONCRETE MIXTURES SHALL CONFORM TO THE FOLLOWING REQUIREMENTS:

CONCRETE MIXTURES		EXPOSURE CLASS					USE		
F_c (PSI)	TEST AGE (DAYS)	F1	S1	W1	C1	F	S	C	
4,000	28								

CONCRETE MIXTURES SHALL CONFORM TO THE MOST STRINGENT REQUIREMENTS FOR EXPOSURE CLASSES SPECIFIED IN THE TABLE ABOVE AND AS PER TABLE 19.3.2.1 WATER-REDUCING ADMIXTURES MAY BE INCORPORATED IN CONCRETE MIX DESIGNS, BUT SHALL CONFORM TO ASTM C 494, AND BE USED IN STRICT ACCORDANCE WITH THE MANUFACTURER'S RECOMMENDATIONS. CALCIUM OR OTHER WATER-SOLUBLE CHLORIDE ADMIXTURES SHALL NOT BE USED.

WATER/CEMENTITIOUS MATERIALS RATIO SHALL BE MEASURED BY WEIGHT AND SHALL BE BASED ON THE TOTAL CEMENTITIOUS MATERIAL. WATER/CEMENTITIOUS MATERIALS RATIO AND WATER CONTENT SHALL BE DETERMINED BY THE SUPPLIER BASED ON STRENGTH REQUIREMENTS AND SHALL EXCEED THE MAXIMUM WATER/CEMENTITIOUS MATERIAL RATIO AND/OR WATER CONTENT f_{w} SHOWN ABOVE OR IN ACI 318 TABLE 19.3.2.1 FOR THE EXPOSURE CLASSES LISTED.

FIELD-MEASURED SLUMP SHALL CONFORM TO THE SUBMITTED CONCRETE MIX DESIGN. TOLERANCE OF SLUMP SHALL CONFORM TO ASTM C 94.

ALL CONCRETE SUBJECT TO EXPOSURE CLASSES F1, F2 OR F3 SHALL BE AIR ENTRAINED. AIR-ENTRAINING AGENTS SHALL CONFORM TO ASTM C 260. THE PERCENTAGE OF TOTAL AIR SHALL BE ACCORDING TO ACI 318 TABLE 19.3.1.1 WITH A FIELD TOLERANCE OF ± 1.5 PERCENT BY VOLUME. THE PERCENTAGE OF TOTAL AIR SHALL BE MEASURED IN THE FIELD AT THE DISCHARGE FROM THE TRUCK.

THE CONTRACTOR SHALL SUBMIT CONCRETE MIX DESIGNS FOR APPROVAL 2 WEEKS PRIOR TO PLACING ANY CONCRETE. THE MIX DESIGN SHALL BE IN CONFORMANCE WITH IBC CHAPTER 19. THE SUBMITTAL SHALL INDICATE WHERE EACH CONCRETE MIX IS TO BE USED ON THE PROJECT, AS WELL AS THE MAXIMUM AGGREGATE SIZE OF EACH MIX. MAXIMUM AGGREGATE SIZE SHALL CONFORM TO THE PROJECT SPECIFICATIONS.

CURING
IF THE AIR TEMPERATURE WILL EXCEED 75 DEGREES F WITHIN 48 HOURS OF PLACING CONCRETE, A MOIST CURE SHALL BE APPLIED TO THE CONCRETE FOR A PERIOD OF 36 HOURS AFTER FINISHING CONCRETE SURFACES. REFER TO THE PROJECT SPECIFICATIONS FOR CURING REQUIREMENTS.

SHOTCRETE
SHOTCRETE SHALL CONFORM TO ACI 508R, ACI 562.1, IBC CHAPTER 19. SHOTCRETE MIX DESIGN, APPLICATION, NOZZLEMAN'S QUALIFICATIONS AND TEST PROCEDURE SHALL BE IN STRICT CONFORMANCE WITH THESE PUBLICATIONS.

REINFORCING STEEL
DEFORMED BARS ASTMA A 615, GRADE 60
HEADED DEFORMED BARS ASTMA A 970, HEAD TYPE HA

REINFORCING SHALL BE SUPPORTED AS SPECIFIED BY THE PROJECT SPECIFICATIONS AND THE CSI MANUAL OF STANDARD PRACTICE. REINFORCING STEEL SHALL BE TIELED IN ACCORDANCE WITH ACI STANDARD OF PRACTICE AS OUTLINED IN ACI 318, "GUIDE TO PRESENTING REINFORCING STEEL DESIGN DETAILS".

LAP ALL REINFORCING BARS AS NOTED IN THE DRAWINGS. WHERE SPACE LENGTH IS NOT SHOWN, USE TYPE I_b (L_b FOR TOP BARS) SPACING PER DEVELOPMENT AND SPLICE LENGTH SCHEDULE. MECHANICAL SPLICES CALLED OUT ON THE PLANS SHALL BE TYPE 1 UNLESS OTHERWISE NOTED. TYPE 1 SPLICES SHALL DEVELOP 125 PERCENT OF THE CAPACITY OF THE SPLICED BARS IN BOTH TENSION AND COMPRESSION. TYPE 2 SPLICES SHALL DEVELOP THE SPECIFIED TENSILE STRENGTH OF THE SPLICED BARS UNLESS OTHERWISE NOTED. ADDITION TO MEETING TYPE 1 SPLICE REQUIREMENTS, SUBMIT ICC-ES OR IAPMO UES REPORT VALID FOR THE 2018 IBC DEMONSTRATING COMPLIANCE OF COUPLERS WITH THESE REQUIREMENTS.

AT THE CONTRACTOR'S OPTION AND WITH THE ARCHITECT'S APPROVAL, HEADED DEFORMED BARS MAY BE USED IN LIEU OF REINFORCING BARS SHOWN WITH STANDARD 90 OR 180 DEGREE HOOKS AND MECHANICAL SPLICES MAY BE USED IN LIEU OF LAP SPLICES. USE OF HEADED DEFORMED MINIBARS IS SUBJECT TO CONFORMANCE WITH ACI 318, SECTION 25.4.4. USE OF MECHANICAL SPLICES IS SUBJECT TO CONFORMANCE WITH ACI 318 SECTION 18.2.7 AND REQUIRES SUBMITTAL OF AN ICC-ES OR IAPMO UES REPORT VALID FOR THE 2018 IBC DEMONSTRATING COMPLIANCE WITH THESE REQUIREMENTS.

REINFORCING STEEL SHALL HAVE PROTECTION AS FOLLOWS, UNLESS NOTED OTHERWISE:

USE	COVER
BEAM STRUTUPS AND COLUMN TIES	1 1/2"
STRUCTURAL SLAB AT GRAB BOTTOM BARS	2"
WALL BARS- INTERIOR FACES	3/4"
EXPOSED TO EARTH OR WEATHER	1 1/2" (#6 AND SMALLER)
FOOTING, PILE CAP, GRADE BEAM BOTTOM BARS	3"
TOP BARS	1 1/2" (#6 AND LARGER)
EXPOSED TO EARTH OR WEATHER	3"
SIDE BARS	2"

WELDING OF REINFORCING, WHERE APPROVED BY THE ARCHITECT, SHALL BE PERFORMED USING LOW HYDROGEN ELECTRODES AND PREHEATED IN ACCORDANCE WITH AWS D1.4. REINFORCING STEEL WELDING CODE, WELDERS AND WELDING PROCEDURES SHALL BE QUALIFIED IN ACCORDANCE WITH AWS D1.4. MATERIALS SHALL CONFORM TO THE FOLLOWINGS:

REINFORCING BARS TO BE WELDED WELDING ELECTRODES ASTMA A 706, GRADE 60, LOW ALLOY E80XX

NONSHRINK GROUT
BASE PLATE GROUT SHALL BE NONSHRINK TYPE WITH MINIMUM $f_c = 8,000$ PSI. ALL OTHER NONSHRINK GROUT SHALL HAVE MINIMUM $f_c = 5,000$ PSI.

LOADING ALLOWANCE
THE CONTRACTOR SHALL PROVIDE 2,000 LINEAR FEET OF #4 REINFORCING STEEL FOR THE ENGINEER TO USE AT THEIR DISCRETION DURING CONSTRUCTION. THE CONTRACTOR SHALL REIMBURSE THE OWNER FOR THE UNRECORDED PORTION.

ANCHORS

POST-INSTALLED ANCHORS

PROVIDE POST-INSTALLED ANCHORS PER THE FOLLOWING SCHEDULE UNLESS NOTED OTHERWISE:

ANCHORS IN CONCRETE		
ANCHOR TYPE	APPROVED ANCHOR(S)	EVALUATION REPORT
ADHESIVE	HILTI HIT-RE 500 SD	ICC-ES ESR-2322
MECHANICAL	HILTI KWIK BOLT T22	ICC-ES ESR-4268

ADHESIVE REINFORCING DOWEL MATERIALS
ADHESIVE REINFORCING DOWELS (ARD) THREADED ARD ASTMA A 615, GRADE 60
ASTMA A 1554, GRADE 36 (CARBON STEEL)
ASTMA A193 B8M CLASS 1 (STAINLESS)

ANCHOR EMBEDMENT DEPTHS LISTED SHALL BE CONSIDERED EFFECTIVE EMBEDMENT DEPTHS AS DEFINED IN THE ICC-ES OR IAPMO UES EVALUATION REPORTS. PROVIDE ANCHOR LENGTH AND HOLE PER EVALUATION REPORT TO ACCOMMODATE THE EFFECTIVE EMBEDMENT SPECIFIED IN THESE DRAWINGS. SEE DETAIL, 11/84 01

MECHANICAL AND ADHESIVE ANCHORS SHALL BE ZINC PLATED CARBON STEEL UNLESS NOTED OTHERWISE. MECHANICAL AND ADHESIVE ANCHORS EXPOSED TO WEATHER SHALL BE STAINLESS STEEL.

DO NOT DAMAGE EXISTING REINFORCEMENT. IF LOCATION OF REINFORCEMENT IS UNKNOWN, SCAN FOR EXISTING REINFORCING STEEL PRIOR TO DRILLING.

USE OF ALTERNATE PRODUCTS, OR OF POST-INSTALLED ANCHORS AT LOCATIONS NOT SHOWN IN THESE DRAWINGS, IS SUBJECT TO THE APPROVAL OF THE ARCHITECT. SUBMIT PROPOSED ANCHORS TO THE ARCHITECT WITH AN ICC-ES OR IAPMO UES REPORT VALID FOR THE 2018 IBC AND DOCUMENTATION SHOWING THAT THE ALTERNATE PRODUCTS PROVIDE EQUIVALENT CAPACITY FOR ALL CONDITIONS IN THIS PROJECT. SUBMITTED ICC-ES OR IAPMO UES REPORTS SHALL DEMONSTRATE THAT THE ANCHORS ARE SUITABLE FOR USE IN CRACKED CONCRETE, WHERE ANCHORS RESIST SEISMIC LOADS OR SUSTAINED TENSION. SUBMITTED ICC-ES AND IAPMO UES REPORTS SHALL DEMONSTRATE THAT THE ANCHORS ARE SUITABLE FOR THE RESISTANCE OF SEISMIC LOADS OR SUSTAINED TENSION (AS APPLICABLE). DOCUMENTATION OF CAPACITY FOR ALTERNATE PRODUCTS MUST BE INCLUDED AS A DEFERRED SUBMITTAL.

ADHESIVES SHALL NOT BE INSTALLED PRIOR TO THE CONCRETE REACHING AN AGE OF 21 DAYS AS REQUIRED BY THE ARCHITECT.

ADHESIVE ANCHORS HORIZONTALLY OR UPWARDLY INCLUDED TO SUPPORT SUSTAINED TENSION LOADS SHALL BE INSTALLED BY PERSONNEL CERTIFIED BY THE ANCHORS' ADHESIVE ANCHOR INSTALLER CERTIFICATION PROGRAM, OR EQUIVALENT PROGRAM.

WELDED HEADED STUDS, WELDED THREADED STUDS, AND DEFORMED BAR ANCHORS
ALL STUDS AND DEFORMED BAR ANCHORS (DBA) SHALL BE AUTOMATICALLY END WELDED IN SHOP OR FIELD WITH EQUIPMENT PROVIDED BY THE MANUFACTURER WITH LENGTH AFTER WELD AS SHOWN ON THE STRUCTURAL DRAWINGS.

TYPE	MATERIAL	SIZE
WELDED HEADED STUDS	AWS D1.1 TYPE B	3/4" UNLESS NOTED OTHERWISE
WELDED THREADED STUDS	ASTM A 1554 TYPE A	1/2" UNLESS NOTED OTHERWISE
DEFORMED BAR ANCHORS	ASTMA A 1064	1/2" UNLESS NOTED OTHERWISE

STRUCTURAL STEEL

REFERENCE SPECIFICATIONS
STRUCTURAL STEEL AISC 360 "SPECIFICATION FOR STRUCTURAL STEEL BUILDINGS"

HIGH STRENGTH BOLTS
RSSC "SPECIFICATION FOR STRUCTURAL JOINTS USING HIGH-STRENGTH BOLTS"

WELDING
AWS D1.1, TYPICAL
AWS D1.3 FOR STEEL DECK AND COLD-FORMED FRAMING
AWS D1.6 FOR STRUCTURAL MEMBERS AND CONNECTIONS
AWS PREQUALIFIED JOINT DETAILS

WELDER CERTIFICATION
AMERICAN WELDING SOCIETY (AWS)

STEEL JOISTS AND BRIDGING
SJI STANDARD SPECIFICATIONS

STEEL DECKING
ANSI/DIN C "STANDARD FOR COMPOSITE STEEL FLOOR DECK-SLABS"
ANSI/DIN RD "STANDARD FOR STEEL ROOF DECK"
ANSI S100 "NORTH AMERICAN SPECIFICATION FOR THE DESIGN OF COLD-FORMED STEEL STRUCTURAL MEMBERS"

STEEL MATERIALS
WIDE FLANGE SHAPES (W AND WT) ASTMA A 992
PLATES (PL) BARS ASTMA A 572 GRADE 50 WHERE NOTED
ANGLES (L), CHANNELS (C) AND MC, ASTMA A 572 GRADE 50 WHERE NOTED
STRUCTURAL TUBES (HSS) ASTMA A 500, GRADE C
STEEL PIPE ASTMA A 53, GRADE B
STEEL PIPE TEES ASTMA A 252, GRADE "B (MOD)"; FY = "60 KSI"
ANCHOR BOLTS ASTM F 3125, GRADE A 325
ASTMA F 1554, GRADE "60"
UNLESS NOTED OTHERWISE
ASTMA A 36, UNLESS NOTED OTHERWISE
70 KSI, LOW HYDROGEN, TYPICAL
60 KSI, MINIMUM, STEEL DECK

STRUCTURAL STEEL DESIGN, FABRICATION AND ERECTION SHALL CONFORM TO THE REQUIREMENTS OF IBC CHAPTER 22. ALL MEMBERS ARE TO BE ERECTED WITH NATURAL MILL CAMBER OR INDUCED CAMBER UP, UNLESS OTHERWISE NOTED ON THE PLANS. SUBSTITUTION OF MEMBER SIZES OR STEEL GRADES WILL NOT BE ALLOWED WITHOUT PRIOR APPROVAL BY THE ARCHITECT. A MINIMUM OF TWO BOLTS IS REQUIRED FOR ALL BEAM CONNECTIONS. ALTERNATIVE CONNECTIONS TO THOSE SHOWN ON THESE DRAWINGS WILL REQUIRE PRIOR APPROVAL BY THE ARCHITECT.

THE CONTRACTOR SHALL BE RESPONSIBLE FOR ALL ERECTION AIDS AND JOINT PREPARATIONS THAT INCLUDE, BUT ARE NOT LIMITED TO, ERECTION ANGLES, LIFT HOLES AND OTHER AIDS. WELDING PROCEDURES, REQUIRED ROOT OPENINGS, ROOT FACE DIMENSIONS, GROOVE ANGLES, BACKING BARS, COPES, SURFACE ROUGHNESS VALUES, AND UNEQUAL PARTS.

PROTECTION OF STEEL
STRUCTURAL STEEL AND CONNECTIONS, INCLUDING PLATES AND OTHER STEEL ITEMS EMBEDDED IN CONCRETE, WHICH ARE EXPOSED TO WEATHER AND NOT TO BE PAINTED ACCORDING TO THE ARCHITECT, SHALL BE HOT-DIPPED GALVANIZED AFTER FABRICATION IN COMPLIANCE WITH ASTM A 123. ALL FIELD WELDS ON GALVANIZED MATERIAL SHALL BE COATED WITH BRUSH APPLIED ZINC-RICH PAINT COMPLYING WITH THE SPECIFICATIONS.

STRUCTURAL STEEL AND CONNECTIONS SHALL BE FIREPROOFED WHERE REQUIRED BY THE ARCHITECT. PRIMARY AND SECONDARY STRUCTURE ARE TO BE AS DEFINED BY THE IBC. STRUCTURAL MEMBERS SHALL BE ASSUMED TO BE IN A THERMAL UNRESTRAINED CONDITION FOR THE PURPOSES OF DETERMINING FIREPROOFING THICKNESS. UL DESIGN PRESENTING REINFORCING STEEL DESIGN DETAILS".

WHERE SPAN-APPLIED CEMENTITIOUS FIREPROOFING IS EXPOSED TO WEATHER, STRUCTURAL STEEL SHALL BE CONSIDERED EXPOSED TO WEATHER, AND SHALL BE PROTECTED ACCORDINGLY.

ALL COATINGS ARE TO FOLLOW THE SPECIFICATIONS AND PRODUCT MANUFACTURERS' INSTRUCTIONS.

WELDING
ALL WELDING SHALL BE IN CONFORMANCE WITH AISC AND AWS STANDARDS, AND SHALL BE PERFORMED BY "AWS-WABO"-CERTIFIED WELDERS. ONLY WELDS THAT ARE PREQUALIFIED, AS DEFINED BY AWS, OR QUALIFIED BY TESTING SHALL BE USED. SHOP DRAWINGS SHALL SHOW ALL WELDING WITH AWS A4 SYMBOLS. WELDS SHOWN ON THE DRAWINGS ARE MINIMUM SIZES. INCREASE WELD SIZE TO AWS MINIMUM SIZES BASED ON USE OF HEADED DEFORMED MINIBARS. WELD SIZE SHALL BE 3/16-INCH, UNLESS NOTED OTHERWISE. WELDS SHOWN ARE FOR THE FINAL CONNECTIONS. FIELD WELD SYMBOLS ARE SHOWN WHERE FIELD WELDS ARE REQUIRED BY THE STRUCTURAL DESIGN. WHERE FIELD WELD IS IDENTIFIED BY THE ARCHITECT, THE CONTRACTOR SHALL BE RESPONSIBLE FOR DETERMINING IF A WELD SHOULD BE SHOP OR FIELD-WELDED IN ORDER TO FACILITATE THE STRUCTURAL STEEL ERECTION.

WELDING OF THE SEISMIC FORCE-RESISTING SYSTEM SHALL BE EXECUTED IN ACCORDANCE WITH THE PROVISIONS OF AWS D1.8 "STRUCTURAL WELDING CODE--SEISMIC SUPPLEMENT". WELDS ASSOCIATED WITH THE SEISMIC FORCE-RESISTING SYSTEM ARE IDENTIFIED WITHIN THESE DRAWINGS AS FOLLOWS:

NOTE WITHIN WELD TAIL	INDICATES WELDS SUBJECT TO REQUIREMENTS OF D 1.8
D 1.8	INDICATES DEMAND CRITICAL WELDS SUBJECT TO ADDITIONAL SPECIFIC REQUIREMENTS WITHIN D 1.8
D 1.8-D/CW	

THE LOWEST ANTICIPATED SERVICE TEMPERATURE IS 30 DEGREES FAHRENHEIT FOR DETERMINATION OF REQUIRED CHARPY V-NOTCH TOUGHNESS LEVEL.

STEEL DECK

STEEL DECK SHALL CONFORM TO ASTM A 653 WHERE THE DECK IS LEFT PERMANENTLY EXPOSED. GALVANIZED COATING SHALL CONFORM TO ASTM A 924. ON OTHER AREAS, GALVANIZED COATING SHALL CONFORM TO ASTM A 924, G60. STEEL DECK SHALL CONFORM TO THE FOLLOWING:

L (F30)	USE
42" MINIMUM	COMPOSITE FLOOR/ROOF SLAB DECK
33" MINIMUM	NONCOMPOSITE STEEL ROOF DECK

MINIMUM DECK GAUGES ARE SHOWN ON PLANS AND ARE BASED ON 3-SPAN, UNSHORED CONDITIONS. HEAVIER DECK GAUGES MAY BE REQUIRED FOR CONDITIONS OTHER THAN THESE. DEPENDING ON MANUFACTURERS AND CONTRACTORS LAYOUT, DECK SUPPLIER SHALL VERIFY DECK GAUGES AND CAPACITIES BASED ON ACTUAL DECK LAYOUT AND SPAN CONDITIONS INCLUDING A 3 PSF SUPERIMPOSED DEAD LOAD DRAWING FOR THE STEEL ROOF DECK. DEVIATIONS IN DECK GAUGES FROM THOSE SHOWN SHALL BE SUBMITTED TO THE ARCHITECT, ALONG WITH A VALID ICC REPORT FOR APPROVAL PRIOR TO SHOP DRAWING.

DECK WELDING SHALL BE IN ACCORDANCE WITH AWS D1.3, "STRUCTURAL WELDING CODE-- SHEET STEEL." ARC SPOT WELD SIZES NOTED ARE BASED ON THE NOMINAL (VISIBLE) DIAMETER.

CONTRACTOR SHALL PROVIDE CLOSURE PLATES, FLASHING, AND ALL MISCELLANEOUS COLD-FORMED FRAMING NECESSARY TO COMPLETE THE WORK. THE MINIMUM BEARING SHALL BE 2 INCHES.

COMPOSITE FLOOR/ROOF STEEL DECK
STEEL FLOOR DECK SHALL BE A COMPOSITE TYPE DECK WITH RIBS AT 12 INCHES ON CENTER OF THE SIZE AND GAUGE SHOWN ON THE PLANS AND DETAILS, OR AN APPROVED EQUAL. ELECTRICAL CONDUIT SHALL NOT BE EMBEDDED IN COMPOSITE FLOORS.

FLOOR DECK FASTENING SHALL BE AS FOLLOWS, UNLESS NOTED OTHERWISE, AND EXCEPT AS INDICATED IN TYPICAL COMPOSITE BEAM DETAILS.

MIN 5/8-INCH DIAMETER ARC-SPOT WELDS AT 12 INCHES ON CENTER AT TRANSVERSE AND PERIMETER SUPPORTS

MIN 5/8-INCH DIAMETER ARC-SPOT WELDS AT 18 INCHES ON CENTER AT LONGITUDINAL SUPPORTS
BUTTON PUNCH OR 1 1/2-INCH TOP OR SIDE SEAM WELD AT 18 INCHES ON CENTER AT SIDE LAP CONNECTIONS

WOOD

WOOD CONSTRUCTION SHALL CONFORM TO ALL REQUIREMENTS OF IBC CHAPTER 23.

SAWN LUMBER
SAWN LUMBER SHALL CONFORM TO THE LATEST EDITION OF "GRADING AND DRESSING RULES" BY WCLUB OR "WESTERN LUMBER GRADING RULES" BY WLB. LUMBER SHALL BE SEASONED DRY WITH A MAXIMUM MOISTURE CONTENT OF 19% AND BE THE SPECIES AND GRADE SPECIFIED BELOW.

USE	GRADE	F_u (PSI) (SINGLE USE)
WALL STUDS	HEM-FIR STUD GRADE DOUGLAS FIR-LARCH STUD GRADE DOUGLAS FIR-LARCH NO. 2	675 900

PLANNING & PLATES
2" TO 4" THICK, 2" AND WIDER
HEM-FIR NO. 2
DOUGLAS FIR-LARCH NO. 2

JOISTS & RAFTERS
HEM-FIR NO. 2
DOUGLAS FIR-LARCH NO. 2

BEAMS & STANGERS
5"x8" AND LARGER
DOUGLAS FIR-LARCH NO. 1

POSTS
5"x6" AND LARGER
DOUGLAS FIR-LARCH NO. 1
DOUGLAS FIR-LARCH NO. 1

GLUED-LAMINATED TIMBER
GLUED-LAMINATED TIMBER SHALL BE MANUFACTURED IN ACCORDANCE WITH ANSII/ACT A190 "STRUCTURAL GLUED LAMINATED TIMBER". APPLY ONE COAT OF PENETRATING END SEALER IMMEDIATELY AFTER TRIMMING IN SHOP OR FIELD. MEMBERS SHALL BE VISUALLY GRADED WESTERN SPECIES MANUFACTURED WITH FRACING APPEARANCE GRADE AND WITH LAYUP COMBINATION AS FOLLOWS:

TYPE	COMBINATION	SPECIES	USES
BEAMS	24F-V4	DF/D/F	SIPLE SPAN
RISKS	24F-V8	DF/D/F	CONTINUOUS OR CANTILEVER SPAN
COLUMNS	COMBINATION 3	DF	ALL
TRUSSES	COMBINATION 3	DF	ALL
PITCHED AND CURVED BEAMS	24F-V8	DF/D/F	ALL

STRUCTURAL COMPOSITE LUMBER
STRUCTURAL COMPOSITE LUMBER PRODUCTS SHALL BE OF THE SIZE AND TYPE SHOWN ON THE DRAWINGS AND MANUFACTURED BY TRUS

STRUCTURAL ABBREVIATIONS

AB	ANCHOR BOLT	IF	INSIDE FACE
ADDL	ADDITIONAL	IN	INCH
ADH	ADHESIVE	INFO	INFORMATION
ADJ	ADJUSTABLE	INT	INTERIOR
AESS	ARCHITECTURALLY EXPOSED STRUCTURAL STEEL ABOVE FINISH FLOOR	JST	JOIST
AFF	K	JT	JOINT
AGG	AGGREGATE	K	KIP (1,000 LBS.)
ANCH	ANCHOR	KSF	KIPS PER SQUARE FOOT
ARCH	ARCHITECTURAL	LF	LINEAL FOOT
ARD	ADHESIVE REINFORCING DOWEL	LH	LONG FACE HORIZONTAL
B/	BOTTOM OF	LLV	LONG LEG VERTICAL
BLDG	BUILDING	LNGT	LONGITUDINAL
BLKG	BLOCKING	LP	LOW POINT
BM	BEAM	LSL	LAMINATED STRAND LUMBER
BN	DIAPHRAGM BOUNDARY NAILING	LVL	LAMINATED VENEER LUMBER
BOT	BOTTOM	MAX	MAXIMUM
BRG	BEARING	MECH	MECHANICAL
BSMT	BASEMENT	MFR	MANUFACTURER
BTWN	BETWEEN	MIN	MINIMUM
BUR	BUILT UP ROOF	MISC	MISCELLANEOUS
C	CAMBER	MOM	MOMENT
CAP	CAPACITY	NIC	NOT IN CONTRACT
CC	CENTER TO CENTER	NO	NUMBER
CDF	CONTROLLED DENSITY FILL	NOM	NOMINAL
CFS	COLD-FORMED STEEL	NS	NEAR SIDE
CIP	CAST-IN-PLACE	NSH	NONSHRINK
CJ	CONSTRUCTION OR CONTROL JOINT	NTS	NOT TO SCALE
CJP	COMPLETE JOINT PENETRATION	OC	ON CENTER
CL	CENTERLINE	OD	OUTSIDE DIAMETER
CLG	CEILING	OF	OUTSIDE FACE
CLR	CLEAR	OPNS	OPENING
CLT	CROSS-LAMINATED TIMBER	OPP	OPPOSITE
CMU	CONCRETE MASONRY UNIT	P	POST
COL	COLUMN	PAF	POWER ACTUATED FASTENER
CONC	CONCRETE	PC	PIECE
CONN	CONNECTION	PC	PILE CAP
CONST	CONSTRUCTION	PEN	PENETRATION
CONT	CONTINUOUS	PJP	PARTIAL JOINT PENETRATION
CONTR	CONTRACTOR	PL	PROPERTY LINE
CONTY	CONTINUTY	PL	PLATE
COORD	COORDINATE	PLWD	PLYWOOD
CTR	CENTER	PNL	PANEL
CY	CUBIC YARD	PSF	POUNDS PER SQUARE FOOT
DB	DIVIDER BEAM	PSI	POUNDS PER SQUARE INCH
DBA	DEFORMED BAR ANCHOR	PT	POST-TENSIONED
DBL	DOUBLE	PRT	PRESERVATIVE-TREATED
DCW	DEMAND CRITICAL WELD	PWT	PREFABRICATED WOOD TRUSS
DEMO	DEMOLISH	R	RADIUS
DET	DETAIL	RD	ROOF DRAIN
DF	DOUGLAS FIR	REIN	REINFORCING
DIA	DIAMETER	REM	REMAIN(DER)
DIAG	DIAGONAL	REQD	REQUIRED
DNG	DECKING	RND	ROUND
DN	DOWN	RO	ROUGH OPENING
DO	DITTO	RTN	RETURN
DWF	DEFORMED WIRE FABRIC	SC	SLIP CRITICAL
DWG	DRAWING	SCHED	SCHEDULE
DWL	DOWEL	SDCI	SEATTLE DEPARTMENT OF CONSTRUCTION AND INSPECTIONS
EA	EACH	SDQ	SPECIAL DUCTILE QUALITY
EF	EACH FACE	SECT	SECTION
EL	ELEVATION	SFRS	SEISMIC FORCE-RESISTING SYSTEM
ELECT	ELECTRICAL	SHT	SHEET
ELEV	ELEVATOR	SHTG	SHEATHING
EN	PANEL EDGE NAILING	SIM	SIMILAR
EQ	EQUAL	SOG	SLAB-ON-GRADE
EQUIP	EQUIPMENT	SP	SPACE
ES	EACH SIDE	SPEC	SPECIFICATION
EW	EACH WAY	EX	EXISTING
EX	EXISTING	SST	STAINLESS STEEL
EXP	EXPANSION	ST	SUSTAINED TENSION ANCHOR
EXT	EXTERIOR	STD	STANDARD
F	FAHRENHEIT	STIFF	STIFFENER
FD	FLOOR DRAIN	STIRR	STIRRUP
FEN	FOUNDATION	STL	STEEL
FF	FINISH FLOOR	STRUCT	STRUCTURAL
FIN	FINISH	SUPP	SUPPORT
FLG	FLANGE	SVM	SYMMETRICAL
FLR	FLOOR	T&B	TOP AND BOTTOM
FOB	FACE OF BUILDING	T&G	TONGUE AND GROOVE
FS	FAR SIDE	TI	TOP OF
FT	FEET	TB	TABLE
FTG	FOOTING	THK	THICK(NESS)
GA	Gauge	THRU	THROUGH
GALV	GALVANIZED	TRANS	TRANSVERSE
GB	GRADE BEAM	TYP	TYPICAL
GEN	GENERAL	UNO	UNLESS NOTED OTHERWISE
GL	GLUED LAMINATED TIMBER	UT	ULTRASONIC TESTING
GOVT	GOVERNMENT	VERT	VERTICAL
GR	GRADE	VIF	VERIFY IN FIELD
GWB	GYPSONUM WALL BOARD	W	W-SHAPE
HF	HEM-FIR	W	WITH
HGR	HANGER	WO	WITHOUT
HK	HOOK	WD	WOOD
HORIZ	HORIZONTAL	WHS	WELDED HEADED STUD
HP	HIGH POINT	WL	WATER LINE
HSS	HOLLOW STRUCTURAL SECTION	WP	WORK POINT
IBC	INTERNATIONAL BUILDING CODE	WSBC	WASHINGTON STATE BUILDING CODE
ID	INSIDE DIAMETER		
IE	INVERT ELEVATION		

STRUCTURAL DRAWING SYMBOLS

CONCRETE SYMBOLS

	CONCRETE COLUMN ABOVE OR PASSING THROUGH THIS LEVEL
	CONCRETE COLUMN BELOW
	REINFORCING TYPE
	STEPPED FOOTING
	CONCRETE WALL ABOVE OR PASSING THROUGH LEVEL
	PARTIAL HEIGHT CONCRETE WALL
	MASONRY WALLS
	CONCRETE IN CROSS SECTION
	EXISTING CONCRETE IN CROSS SECTION

STEEL SYMBOLS

	STEEL COLUMN ABOVE OR PASSING THROUGH THIS LEVEL
	STEEL COLUMN BELOW THIS LEVEL
	COLUMN SPLICE PER FRAME ELEVATIONS
	COLUMN SPLICE TYPE
	DOUBLER PLATE PER FRAME ELEVATIONS
	STIFFENER PLATES PER FRAME ELEVATIONS
	BOTH DOUBLER & STIFFENER PLATES
	STEEL IN CROSS SECTION

GENERAL SYMBOLS

	GRID BUBBLE
	SURFACE - SLOPE UP
	SURFACE - STEPPED
	SURFACE - SLOPE DOWN
	SURFACE - SLOPE TWO WAYS
	UNDISTURBED SOIL, COMPACTED SOIL, BACKFILL, OR ANY PREPARED SUBGRADE. SEE SPECIFICATIONS FOR TYPE OF MATERIAL AND PREPARATION METHOD.
	PLAN NORTH
	STANDARD SECTION CUTS
	BUILDING SECTION CUTS
	ELEVATION OF WALL OR FRAME
	SPOT ELEVATION: TOP OF PLYWOOD TOP OF CONCRETE TOP OF STEEL
	TOP OF CONCRETE ELEVATION
	TOP OF STEEL ELEVATION
	REFERENCE ELEVATION. REFER TO PLAN UNLESS NOTED OTHERWISE.
	ELEVATION OF LEVEL
	WORKPOINT
	DIRECTION OF DOWNWARD SLOPE
	DIRECTION OF SPAN
	EXISTING FRAMING

WOOD SYMBOLS

	HINGE CONNECTION
	GLULAM SECTION
	ENGINEERED LUMBER SECTION (PSL, LSL, LVL)
	SOLID WOOD SECTION
	SOLID WOOD BLOCKING SECTION
	BUNDLED STUDS, WOOD POST
	PLYWOOD SECTION
	BEAM / GIRDER / JOIST
	WALL ABOVE THIS LEVEL WITH HEADER BELOW
	WALL BELOW THIS LEVEL WITH HEADER BELOW
	WALL ABOVE THIS LEVEL
	WALL BELOW THIS LEVEL

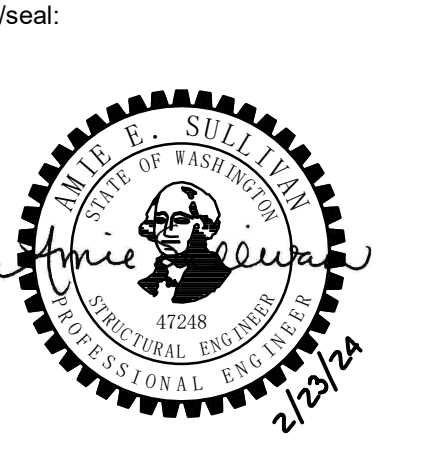
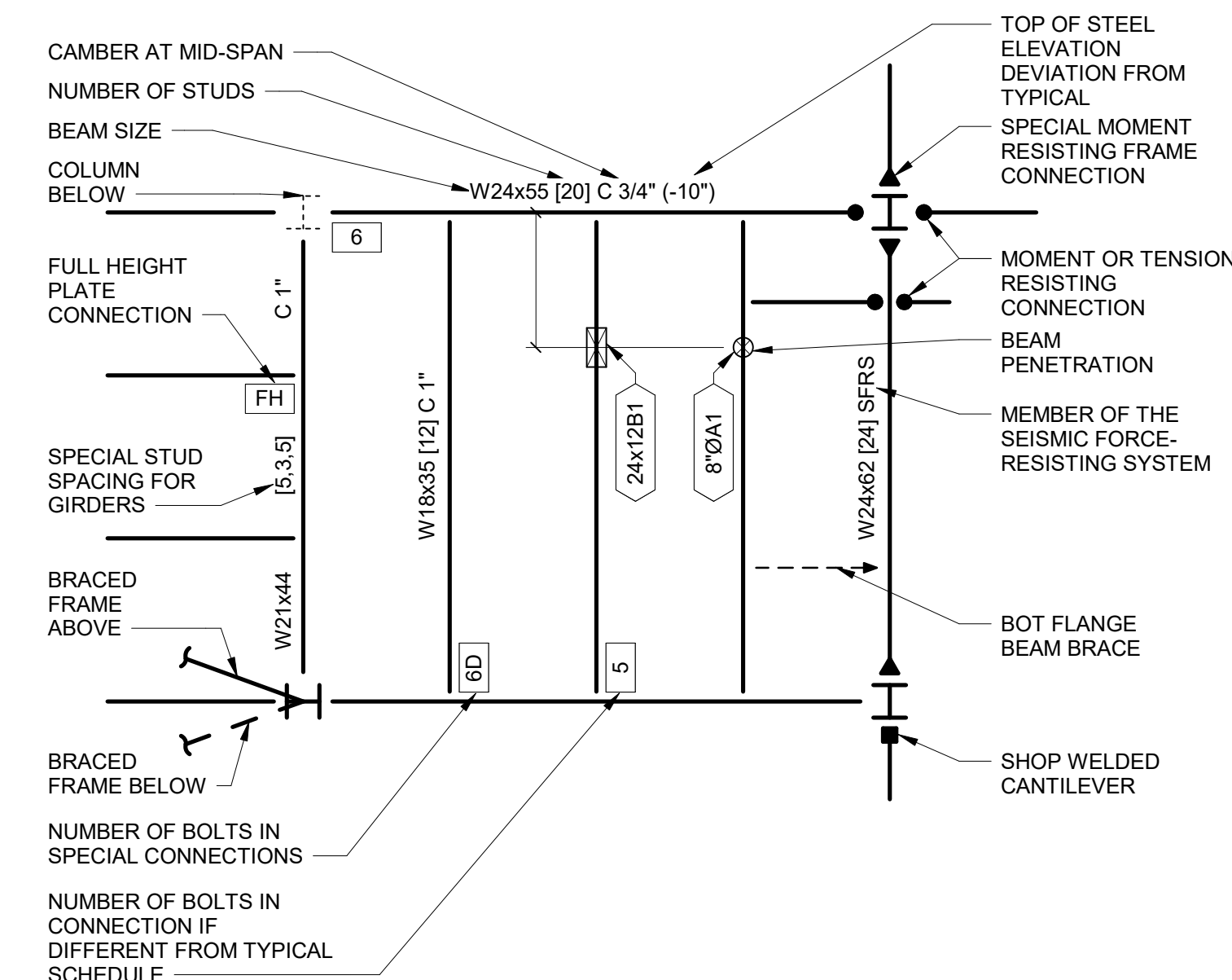

stamp: seal

project engineer: CRL
project manager: JRS
drawn by: RMF
checked by: AES
job no.: 2200638

revisions:

no. date description:

PERMIT
09/08/2023

ISSUE: STRUCTURAL ABBREVIATIONS AND SYMBOLS

sheet: S0.02

1601 Fifth Avenue, Suite 1600
Seattle, WA 98101
206.462.5822
kpff.com



1 LOAD MAP - BASEMENT LEVEL

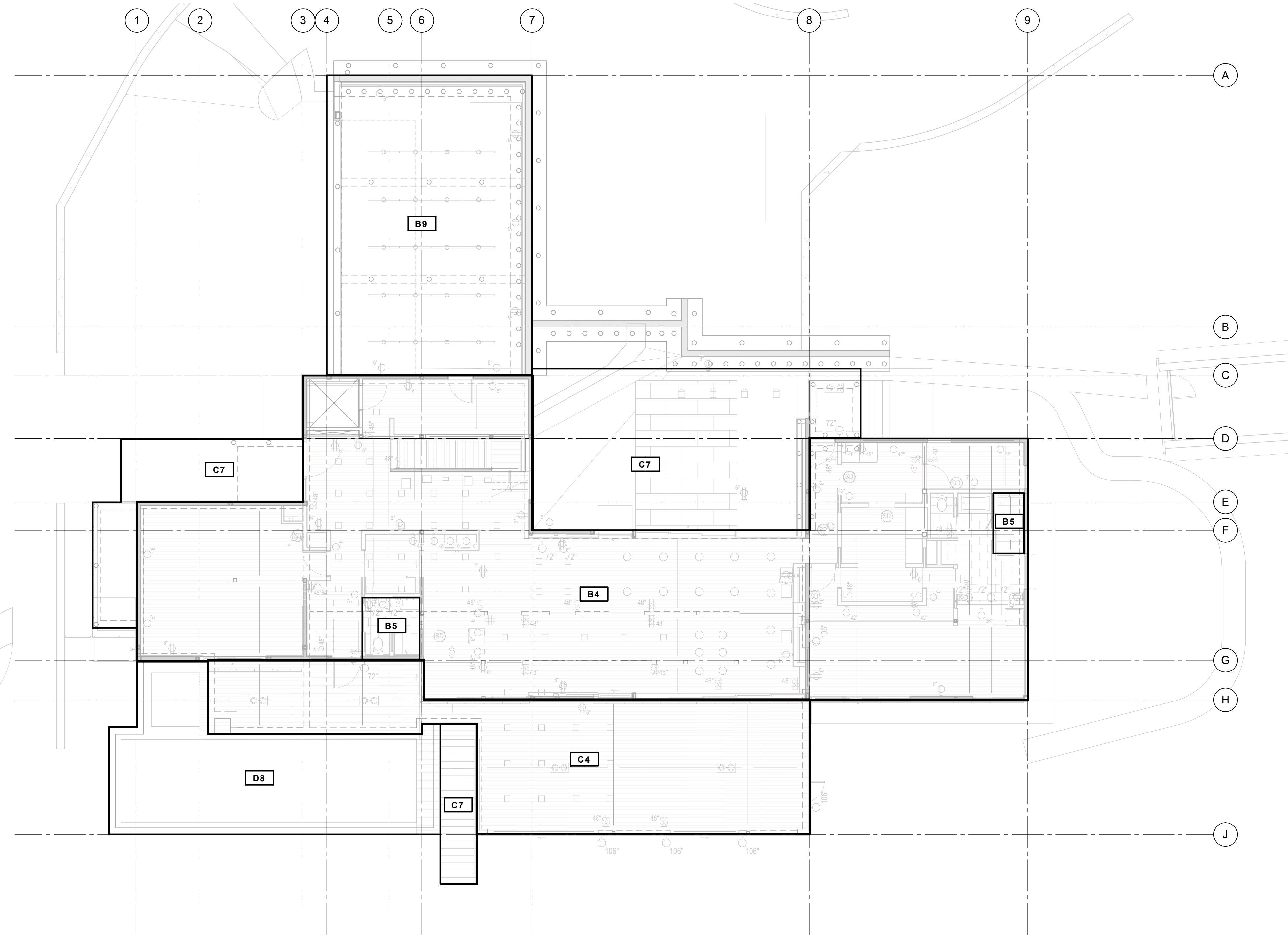

2 LOAD MAP - MAIN LEVEL

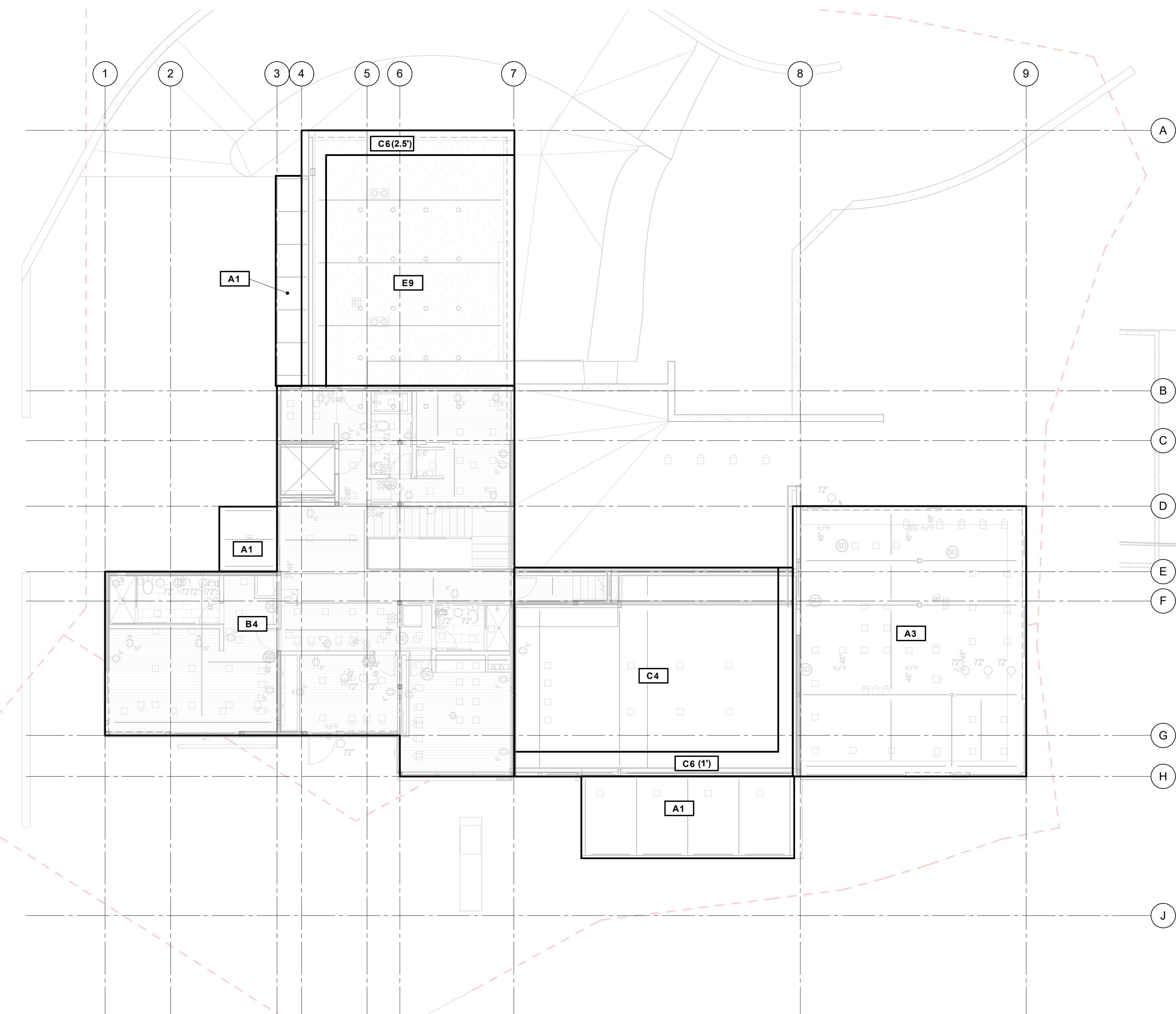

3 LOAD MAP - UPPER LEVEL

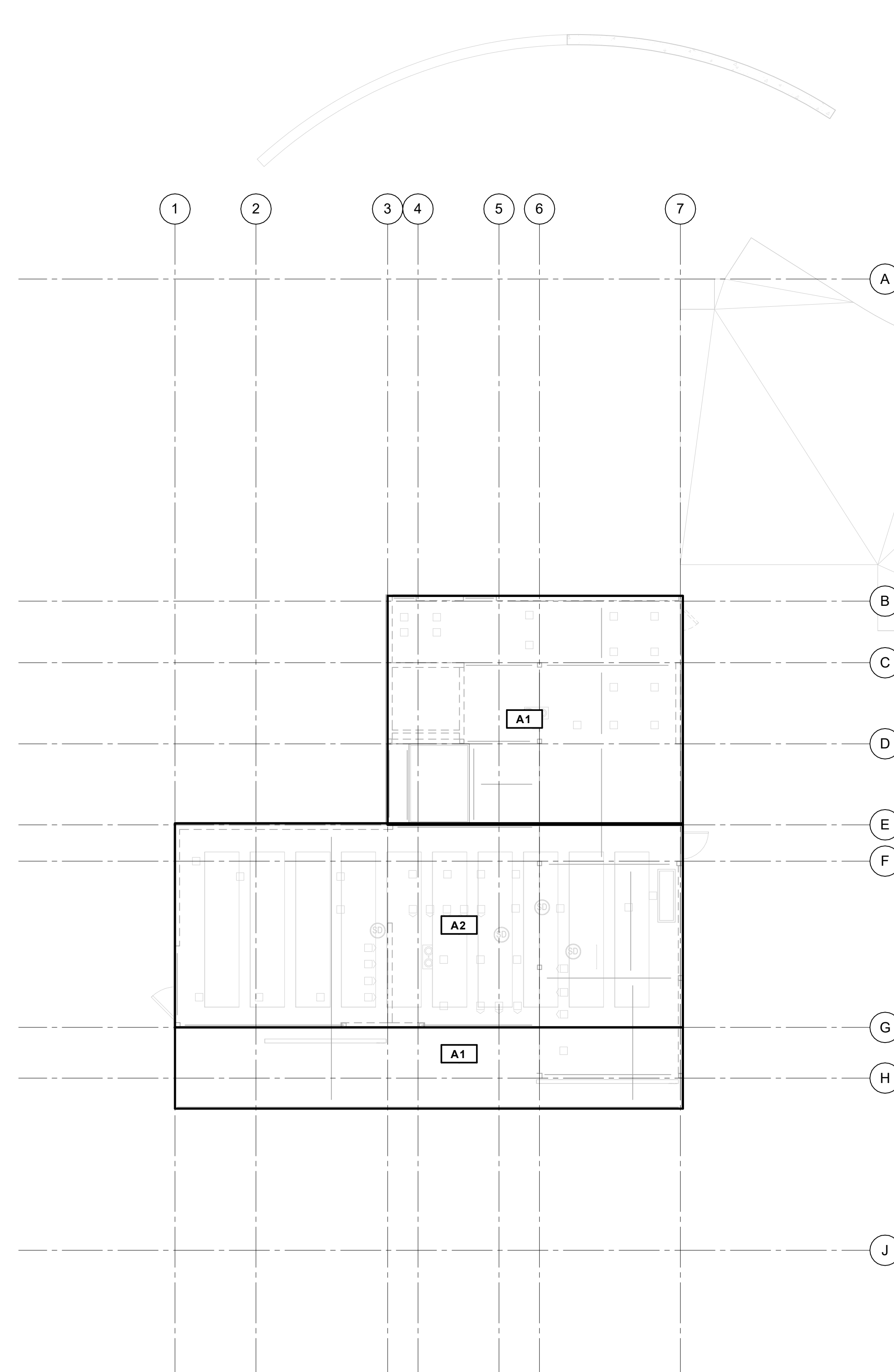

4 LOAD MAP - UPPER ROOF

LIVE LOAD SCHEDULE			
TYPE MARK	DESCRIPTION	LOAD, PSF (R=REDUCIBLE)	TYPE COMMENTS
A	ROOF	20 (R) LIVE 25 SNOW	-
B	INTERIOR RESIDENTIAL	40 (R)	-
C	EXTERIOR TERRACE	60 (R) LIVE 25 SNOW	-
D	POOL	60 (R)	-
E	ELEVATED PARKING	250	-

SUPERIMPOSED DEAD LOAD SCHEDULE			
TYPE MARK	DESCRIPTION	LOAD, PSF	TYPE COMMENTS
1	TYPICAL ROOF	14	-
2	ROOF WITH SOLAR PV ARRAY	16	NOTE 7
3	GREEN ROOF	44	-
4	WOOD FRAMED FLOOR	13	-
5	WOOD FRAMED FLOOR WITH TILE	24	-
6	PLANTER	133	-
7	FLOOR AT GRADE	5	-
8	POOL, 4'-0" WATER HEIGHT	270	-
9	4" TOPPING SLAB	55	-

- LOAD SCHEDULE NOTES:**
- INDICATES LIVE LOAD AND SUPERIMPOSED LOAD PER SCHEDULES. LOADING OCCURS WITHIN REGIONS BOUND BY BOLD LINES.
 - MAXIMUM DEPTH OF SOIL OR WATER, WHERE APPLICABLE
 - SUPERIMPOSED DEAD LOAD
 - LIVE LOAD
 - (R) INDICATES LIVE LOADS ARE REDUCED IN ACCORDANCE WITH BUILDING CODE PROVISIONS.
 - + 15 INDICATES 15 PSF NON REDUCIBLE PARTITION LOAD.
 - EXTERIOR BALCONIES AND DECKS ARE DESIGNED FOR 1.5 TIMES THE OCCUPANCY SERVED, 100 PSF MAXIMUM.
 - WHERE EQUIPMENT WEIGHTS EXCEED 150 PSF, FLOORS ARE DESIGNED FOR ACTUAL EQUIPMENT WEIGHT + 4" HOUSEKEEPING PAD + 40 PSF IN OPEN AREAS.
 - REFER TO IBC TABLE 1607.1 FOR RELEVANT CONCENTRATED LIVE LOADS.
 - SDL INCLUDES 2 PSF FOR PV PANELS.
 - TOTAL SDL IS THE SOIL OR WATER DEPTH TIMES THE LISTED DENSITY IN PCF, PLUS THE ADDITIONAL SDL LISTED IN THE SCHEDULE.



project engineer: CBL
project manager: JRS
drawn by: BMF
checked by: AES
job no.: 220638

revisions:

no.: date: description:

PERMIT
09/08/2023

sheet:
S1.01



project engineer: CRL
 project manager: JRS
 drawn by: BMF
 checked by: AES
 job no.: 220638

revisions:

1 02/23/24 R1
 no.: date: description:

PERMIT
 09/08/2023

FOUNDATION PLAN

sheet:
S2.00

- GENERAL PLAN NOTES:**
- REFERENCE DRAWINGS:
 S0.XX - STRUCTURAL NOTES, SPECIAL INSPECTION SCHEDULE, SYMBOLS AND ABBREVIATIONS
 S1.01 - LOAD MAPS
 S4.XX - TYPICAL CONCRETE DETAILS
 S5.XX - TYPICAL STEEL DETAILS
 S6.XX - TYPICAL WOOD DETAILS
 S7.0X - TYPICAL WOOD DETAILS
 SH.X - SHORING DRAWINGS
- FOUNDATION PLAN NOTES:**
- F1. SEE 6/54.01 FOR BEAM SCHEDULE.
 F2. SEE 1/54.02 FOR CONTINUOUS FOOTING SCHEDULE.
 F3. STRUCTURAL SLAB AT-GRADE SHALL BE 8" THICK WITH #4 @ 18" OC T&S PRIMARY REINF, #4 @ 18" OC T&S REINFORCEMENT, UNO.
 F4. (FWD) INDICATES FOOTING TYPE AND BOTTOM OF FOOTING ELEVATION. SEE 1/54.02.
 (99'-0") GB-X INDICATES GRADE BEAM TYPE. SEE 6/54.01.
 (PC-2) INDICATES PILE CAP PER 10/54.02.
 F7. [Symbol] INDICATES AREA OF TOPPING SLAB OVER SLIP MEMBRANE.
 F8. [Symbol] INDICATES AREA OF 4" SLAB OVER EPS GEOFOAM.
- WOOD FRAMING PLAN NOTES:**
- W1. SEE THE ARCHITECTURAL DRAWINGS FOR WALL TYPES AND FOR NON-BEARING WALL LOCATIONS. WALL STUDS SHALL BE 2x6 @ 16" OC. LINO WALL HEADERS ARE PER 1/58.01 UNO.
 W2. DIMENSIONS SHOWN ARE TO FACE OF STUD, UNO.
 W3. [Symbol] INDICATES HOLD-DOWN AND COMPRESSION STUDS PER 3/98.02.
 W4. [Symbol] INDICATES NUMBER OF BUNDLED STUDS LOCATED UNDER BEAM ABOVE PER 3/98.02.
 W5. [Symbol] INDICATES WOOD SHEAR WALL ABOVE PER 9/98.02. "SW-X" DENOTES PREFABRICATED SIMPSON WOOD STRONG WALL SHEAR WALL.
- BASEMENT WALL NOTES:**
- B1. 12" CONCRETE WALL WITH #7 @ 9" OC VERT OF #7 @ 12" OC VERT IF #4 @ 16" OC HORIZ EF BIDDER-DESIGNED HELICAL ANCHORS TO RESIST 2.7 KR ALLOWABLE LATERAL LOAD WITHIN EXTENTS SHOWN. CONTRACTOR TO COORDINATE ANCHOR QUANTITY, PLACEMENT, AND ANCHORAGE INTO WALL FOUNDATIONS WITH GEOTECH AND SEOR.
 B2. PROVIDE 6" MIN CLEARANCE FROM HELICAL ANCHOR TO ANY STEEL PIPE PILE. CONTRACTOR TO COORDINATE EXACT ANCHOR LOCATION WITH BIDDER/DESIGNER. ANTICIPATED CONSTRUCTION SEQUENCE IS INSTALLATION OF HELICAL ANCHORS BEFORE MARK LEVEL PIPE PILES.

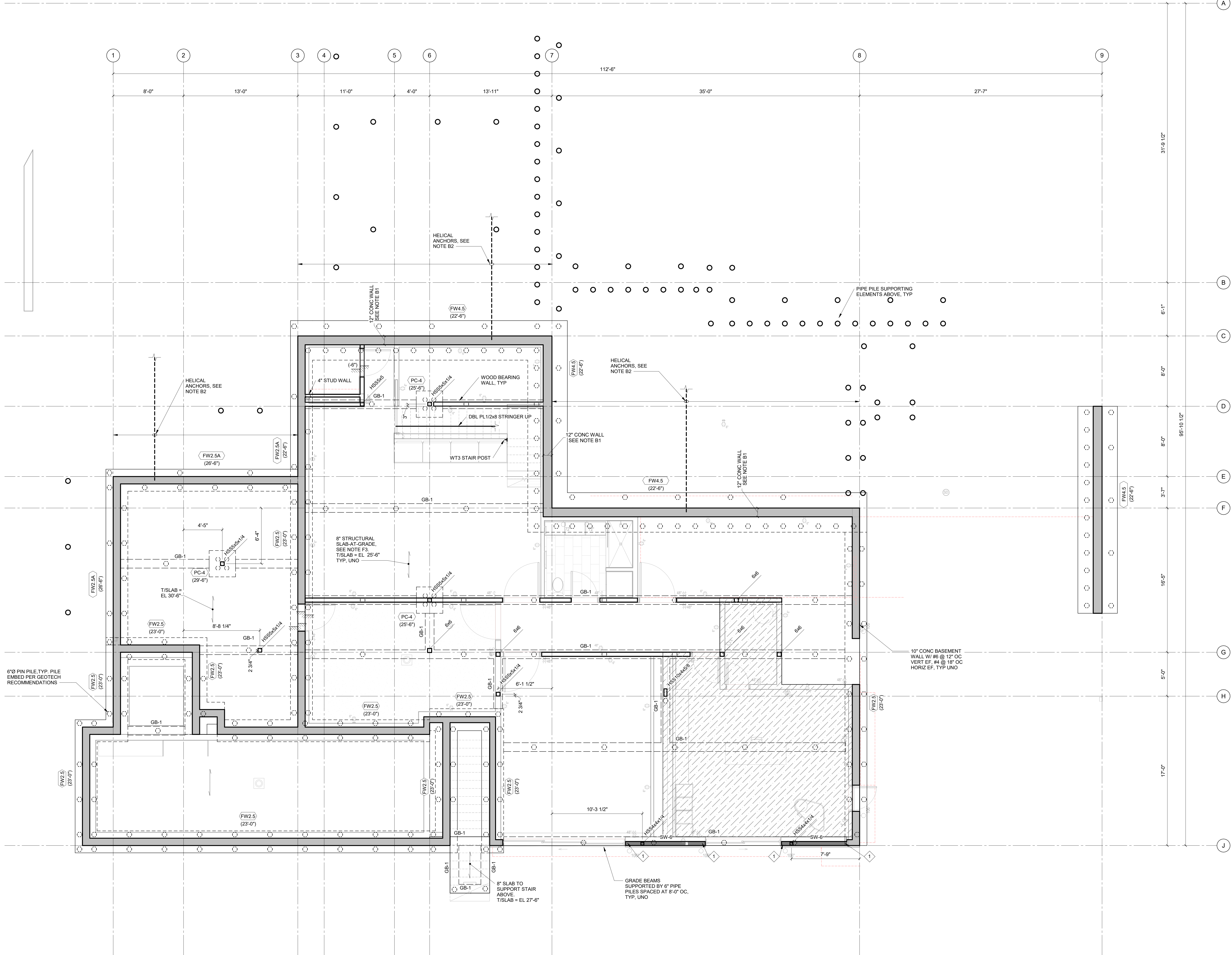

1 FOUNDATION PLAN
 1/4" = 1'-0"

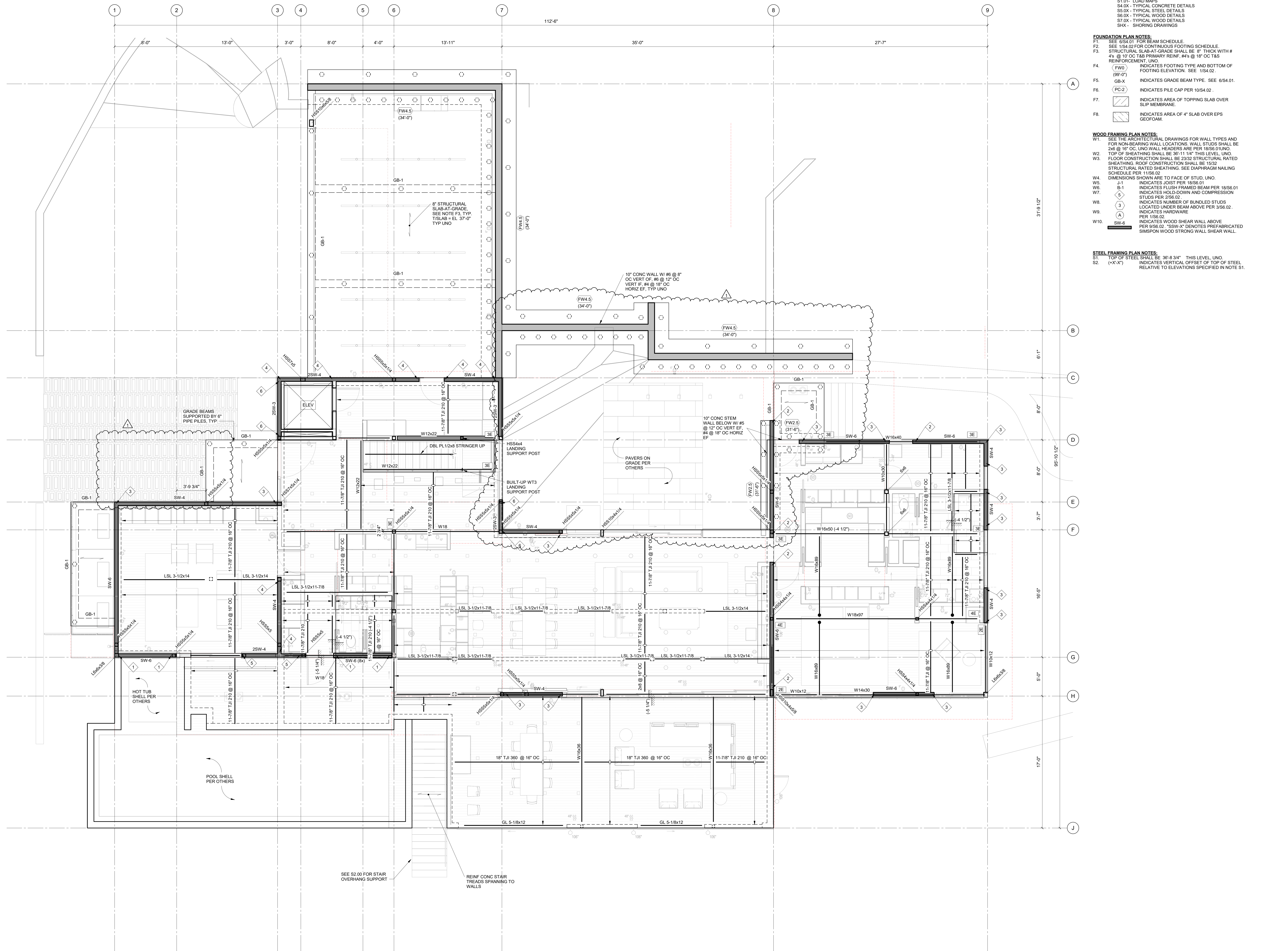

- GENERAL PLAN NOTES:**
 G1. REFERENCE DRAWINGS:
 S0.0X - STRUCTURAL NOTES, SPECIAL INSPECTION SCHEDULE, SYMBOLS AND ABBREVIATIONS
 S1.01 - LOAD MAPS
 S4.0X - TYPICAL CONCRETE DETAILS
 S5.0X - TYPICAL STEEL DETAILS
 S6.0X - TYPICAL WOOD DETAILS
 S7.0X - TYPICAL WOOD DETAILS
 SHX - SHORING DRAWINGS
- FOUNDATION PLAN NOTES:**
 F1. SEE 6/24.01 FOR BEAM SCHEDULE.
 F2. SEE 1/24.02 FOR CONTINUOUS FOOTING SCHEDULE.
 F3. STRUCTURAL SLAB AT GRADE SHALL BE 8" THICK WITH #4 @ 10" OC T&B PRIMARY REIN; #4 @ 18" OC T&B REINFORCEMENT UNO.
 F4. (FW0) INDICATES FOOTING TYPE AND BOTTOM OF FOOTING ELEVATION. SEE 6/24.01.
 F5. GB-X INDICATES GRADE BEAM TYPE. SEE 6/24.01.
 F6. (FC-2) INDICATES PILE CAP PER 10/24.02.
 F7. (Hatched) INDICATES AREA OF TOPPING SLAB OVER SLIP MEMBRANE.
 F8. (Hatched) INDICATES AREA OF 4" SLAB OVER EPS GEOFOAM.
- WOOD FRAMING PLAN NOTES:**
 W1. SEE THE ARCHITECTURAL DRAWINGS FOR WALL TYPES AND FOR NON-BEARING WALL LOCATIONS. WALL STUDS SHALL BE 2X6 @ 16" OC UNO AND WALL HEADERS ARE PER 18/26.01 UNO. TOP OF SHEATHING SHALL BE 35'-11 1/4" THIS LEVEL UNO.
 W2. FLOOR CONSTRUCTION SHALL BE 2X12 STRUCTURAL RATED SHEATHING. ROOF CONSTRUCTION SHALL BE 1X12 STRUCTURAL RATED SHEATHING. SEE DIAPHRAGM NAILING SCHEDULE PER 1/18.02.
 W3. DIMENSIONS SHOWN ARE TO FACE OF STUD UNO.
 W4. J-1 INDICATES JOIST PER 18/26.01.
 W5. F1 INDICATES FLUSH FRAMED BEAM PER 18/26.01.
 W6. (D) INDICATES HOLD-DOWN AND COMPRESSION STUDS PER 2/28.02.
 W7. (S) INDICATES NUMBER OF BUNDLED STUDS LOCATED UNDER BEAM ABOVE PER 3/26.02.
 W8. (A) INDICATES HARDWARE PER 1/26.02.
 W9. (SW-X) INDICATES WOOD SHEAR WALL ABOVE PER 9/26.02. "SW-X" DENOTES PREFABRICATED SIMPSON WOOD STRONG WALL SHEAR WALL.
 W10. (SW-6)
- STEEL FRAMING PLAN NOTES:**
 S1. TOP OF STEEL SHALL BE 35'-8 3/4" THIS LEVEL UNO.
 S2. (X-X') INDICATES VERTICAL OFFSET OF TOP OF STEEL RELATIVE TO ELEVATIONS SPECIFIED IN NOTE S1.

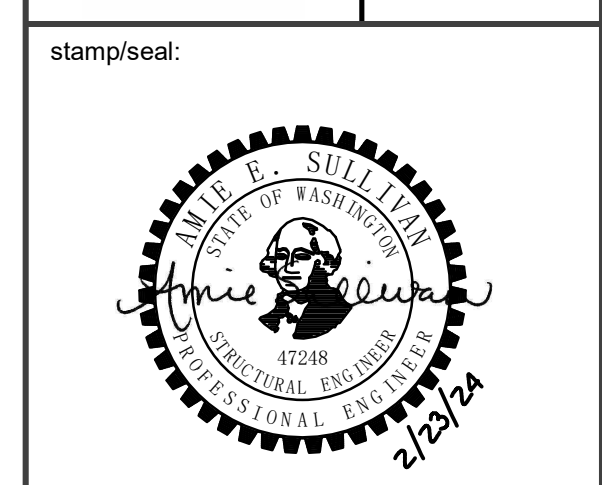

① MAIN LEVEL FRAMING AND FOUNDATION PLAN
 1/4" = 1'-0"

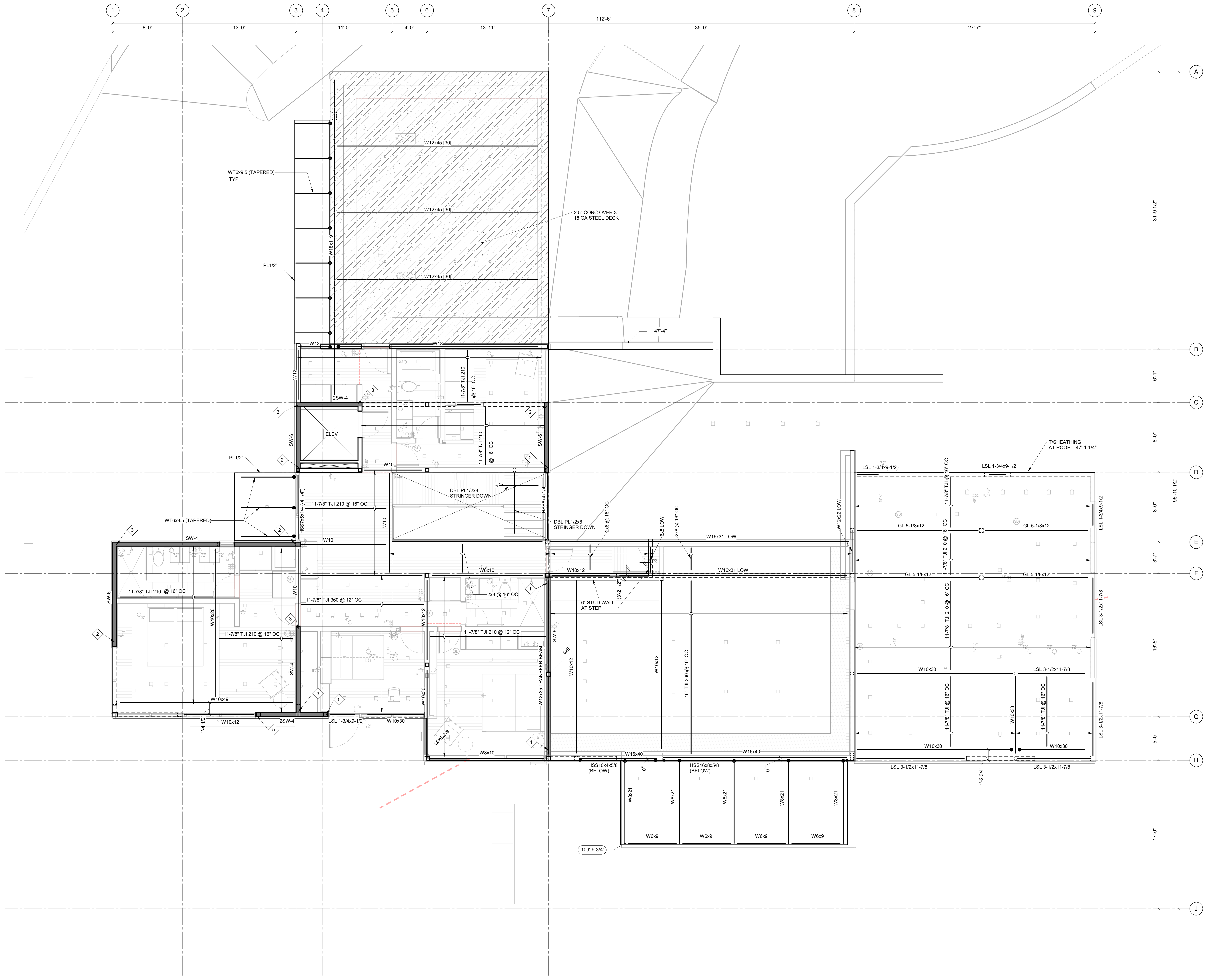

GENERAL PLAN NOTES
01. REFERENCE DRAWINGS:
S0.0X - STRUCTURAL NOTES, SPECIAL INSPECTION SCHEDULE, SYMBOLS AND ABBREVIATIONS
S1.01 - LOAD MAPS
S4.0X - TYPICAL CONCRETE DETAILS
S5.0X - TYPICAL STEEL DETAILS
S6.0X - TYPICAL WOOD DETAILS
S7.0X - TYPICAL WOOD DETAILS
SHX - SHORING DRAWINGS

WOOD FRAMING PLAN NOTES:
W1. SEE THE ARCHITECTURAL DRAWINGS FOR WALL TYPES AND FOR NON-BEARING WALL LOCATIONS. WALL STUDS SHALL BE 2x6 @ 16\"/>

STEEL FRAMING PLAN NOTES:
S1. TOP OF STEEL SHALL BE 47'-0" THIS LEVEL UNO.
S2. (+X-X") INDICATES VERTICAL OFFSET OF TOP OF STEEL RELATIVE TO ELEVATIONS SPECIFIED IN NOTE S1.



stamp: seal

kpff

1601 Fifth Avenue, Suite 1600
Seattle, WA 98101
206.621.5822
kpff.com

project engineer: CRL
project manager: JRS
drawn by: RMF
checked by: AES
job no.: 220638

1 UPPER LEVEL FRAMING PLAN

1/4" = 1'-0"

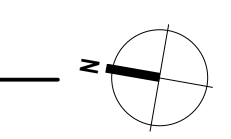



- GENERAL PLAN NOTES**
01. REFERENCE DRAWINGS:
 S0.0X - STRUCTURAL NOTES, SPECIAL INSPECTION SCHEDULE, SYMBOLS AND ABBREVIATIONS
 S1.01 - LOAD MAPS
 S4.0X - TYPICAL CONCRETE DETAILS
 S5.0X - TYPICAL STEEL DETAILS
 S6.0X - TYPICAL WOOD DETAILS
 S7.0X - TYPICAL WOOD DETAILS
 SHX - SHORING DRAWINGS
- WOOD FRAMING PLAN NOTES:**
- W1. SEE THE ARCHITECTURAL DRAWINGS FOR WALL TYPES AND FOR NON-BEARING WALL LOCATIONS: WALL STUDS SHALL BE 2x6 @ 16\"/>

W2. TOP OF SHEATHING SHALL BE 57'-1\"/>

W3. FLOOR CONSTRUCTION SHALL BE 2032 STRUCTURAL RATED SHEATHING - ROOF CONSTRUCTION SHALL BE 1532 STRUCTURAL RATED SHEATHING. SEE DIAPHRAGM NAILING SCHEDULE PER 11/56.02.

W4. S-1 INDICATES JOIST PER 18/56.01.
 W5. B-1 INDICATES FLUSH FRAMED BEAM PER 18/56.01.
 W6. (A) INDICATES HARDWARE PER 1/56.02.

STEEL FRAMING PLAN NOTES:

S1. TOP OF STEEL SHALL BE 56'-10 1/2\"/>

S2. (+X-X') INDICATES VERTICAL OFFSET OF TOP OF STEEL RELATIVE TO ELEVATIONS SPECIFIED IN NOTE S1.



project engineer: CRL
 project manager: JRS
 drawn by: BMF
 checked by: AES
 job no.: 220638

revisions:

no.	date	description

1 UPPER ROOF FRAMING PLAN
 1/4" = 1'-0"

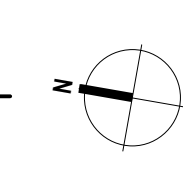

f _c = 4,000 PSI		f _y = 60,000 PSI	
SIZE	Ld	Ld	Ld
#4	19 (28)	25 (37)	32 (48)
#5	24 (36)	31 (46)	40 (60)
#6	28 (43)	37 (55)	48 (73)
#7	42 (62)	54 (81)	70 (105)
#8	47 (71)	62 (92)	80 (120)
#9	54 (80)	70 (104)	90 (136)
#10	60 (90)	78 (117)	102 (153)
#11	67 (100)	87 (130)	113 (170)
#14	80 (120)	104 (157)	N/A
#18	107 (161)	139 (209)	N/A

ABBREVIATIONS

db = BAR DIAMETER
Ld = TENSION DEVELOPMENT LENGTH
L_h = TENSION DEVELOPMENT LENGTH FOR A TOP BAR
L_b = CLASS B LAP SPlice LENGTH, 1.3 L_d
L_h = CLASS B LAP SPlice LENGTH FOR A TOP BAR, 1.3 L_d
L_h = TENSION DEVELOPMENT LENGTH FOR A STANDARD HOOK

NOTES:

- USE THE LENGTHS IN THIS SCHEDULE, UNLESS NOTED OTHERWISE.
- USE LENGTH (L) WHEN BAR COVER IS db OR LESS OR BAR CLEAR SPACING IS 2db OR LESS.
- A TOP BAR IS A HORIZONTAL BAR WITH MORE THAN 12" OF FRESH CONCRETE CAST BELOW IT.
- FOR GRADE 80 BARS, MULTIPLY ABOVE VALUES BY 1.33.

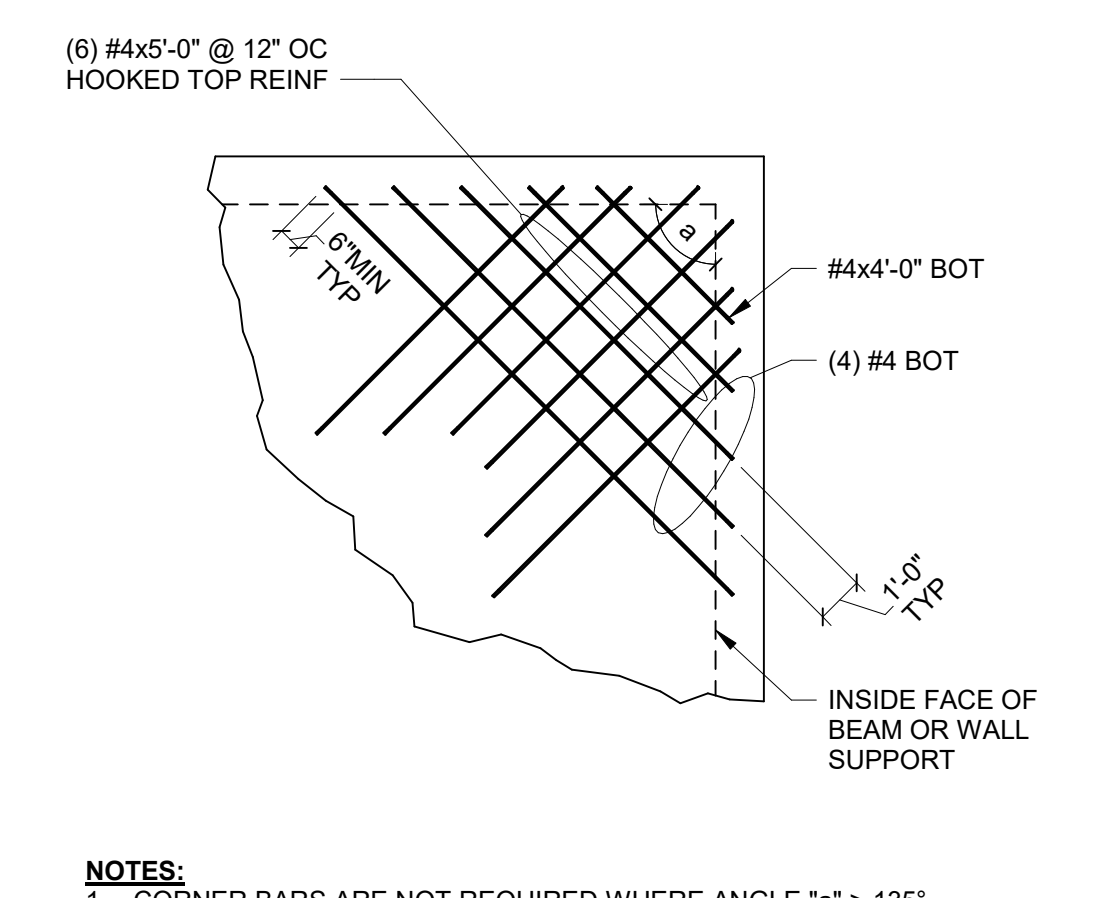
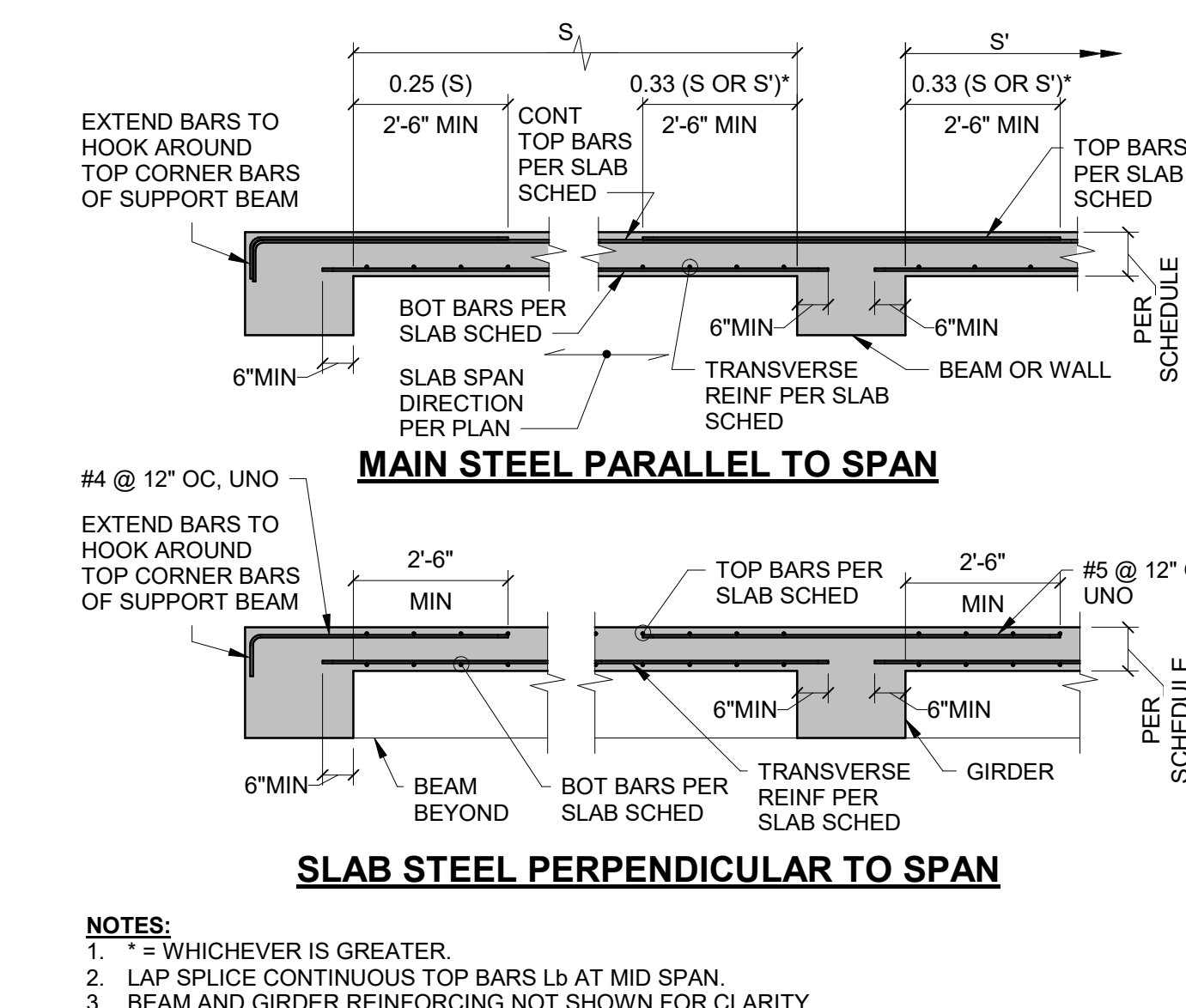
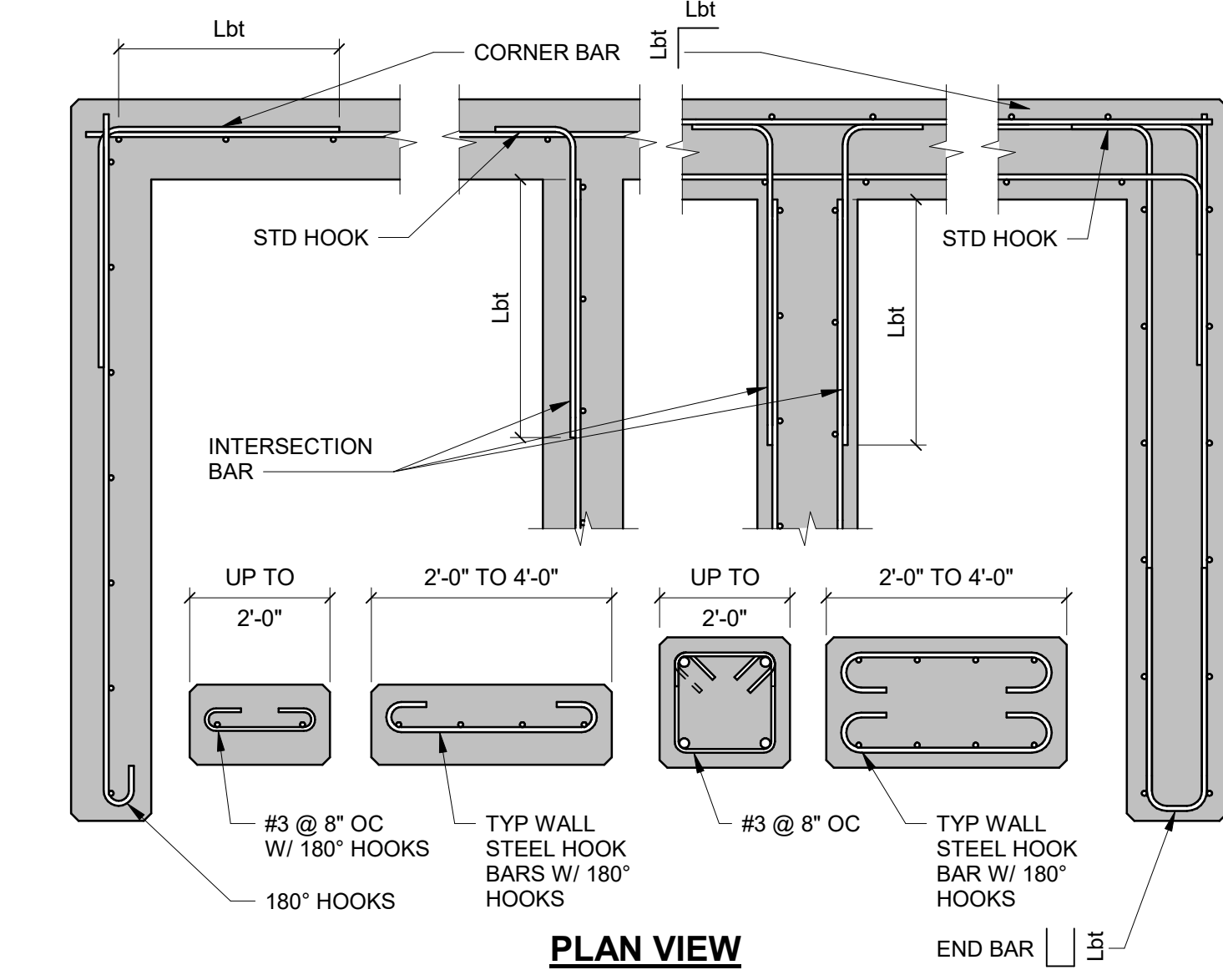
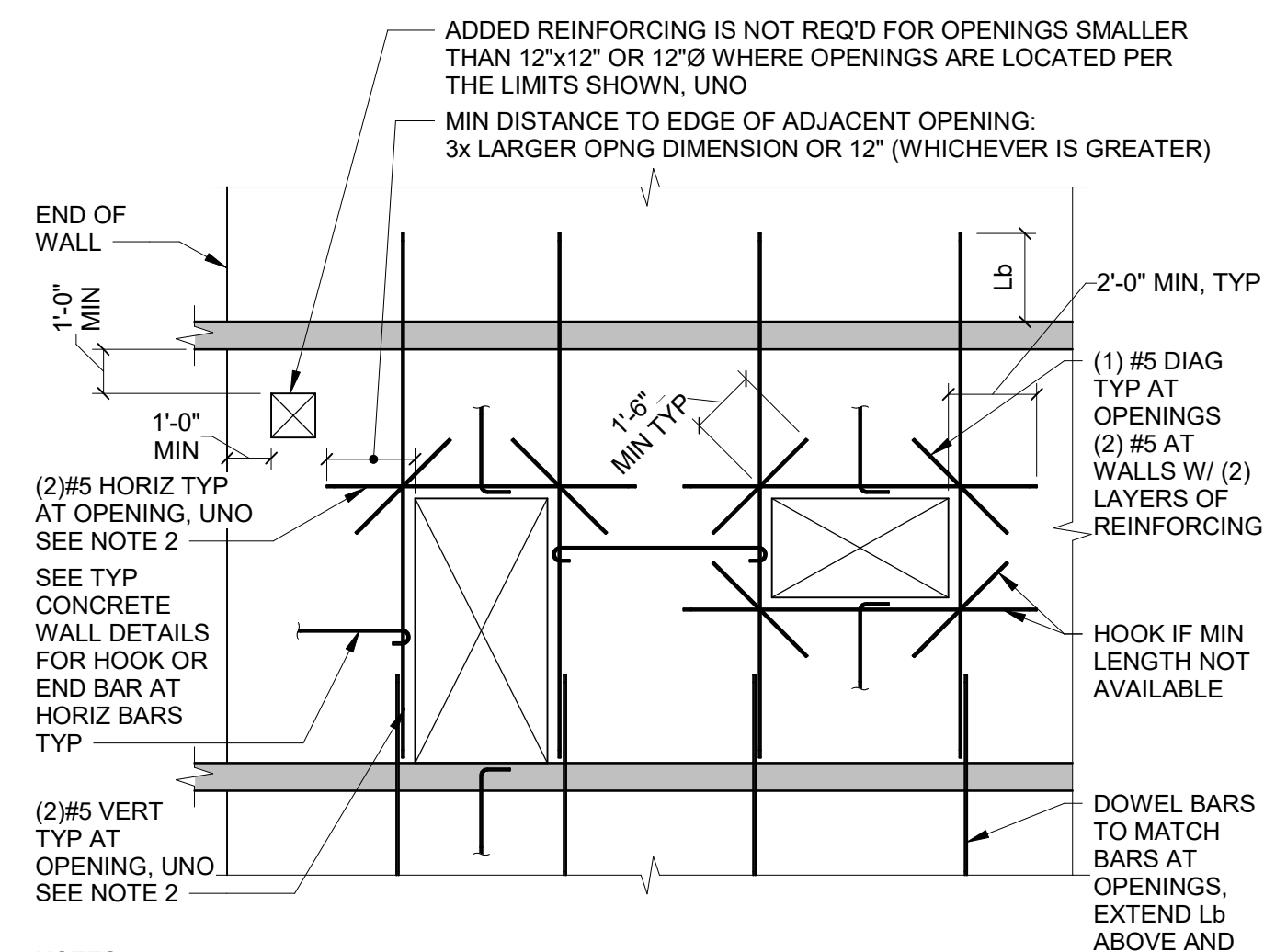

1 DEVELOPMENT AND SPLICE LENGTH SCHED
12" = 1'-0"

2 TYP CONCRETE WALL REINFORCING
NO SCALE

3 TYP CONCRETE WALL DETAILS
NO SCALE

4 TYP ONE-WAY LAB REIN PLACEMENT
NO SCALE

5 BARS AT RESTRAINED CORNERS
NO SCALE

TYPE MARK	SIZE (IN)		LONGITUDINAL REINFORCEMENT			STIRRUPS			TYPE COMMENTS		
	B	D	TOP LEFT	TOP RIGHT	BOT	SIZE	TYPE	SPACING			
GB-1	12	18	(3) #5	-	(3) #5	-	(3) #5	-	#4 T2	6" OC	PROVIDE PIN PILES @ 8'-0" OC UNO.

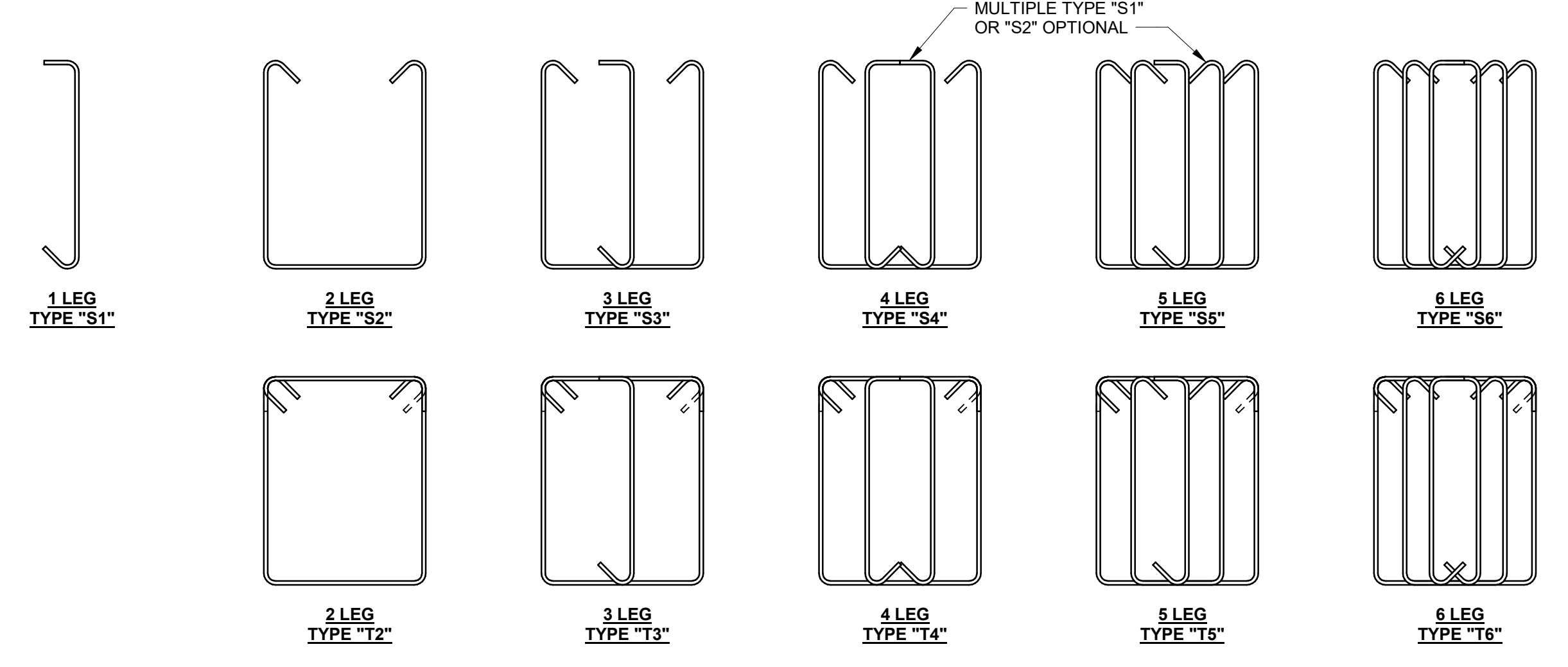
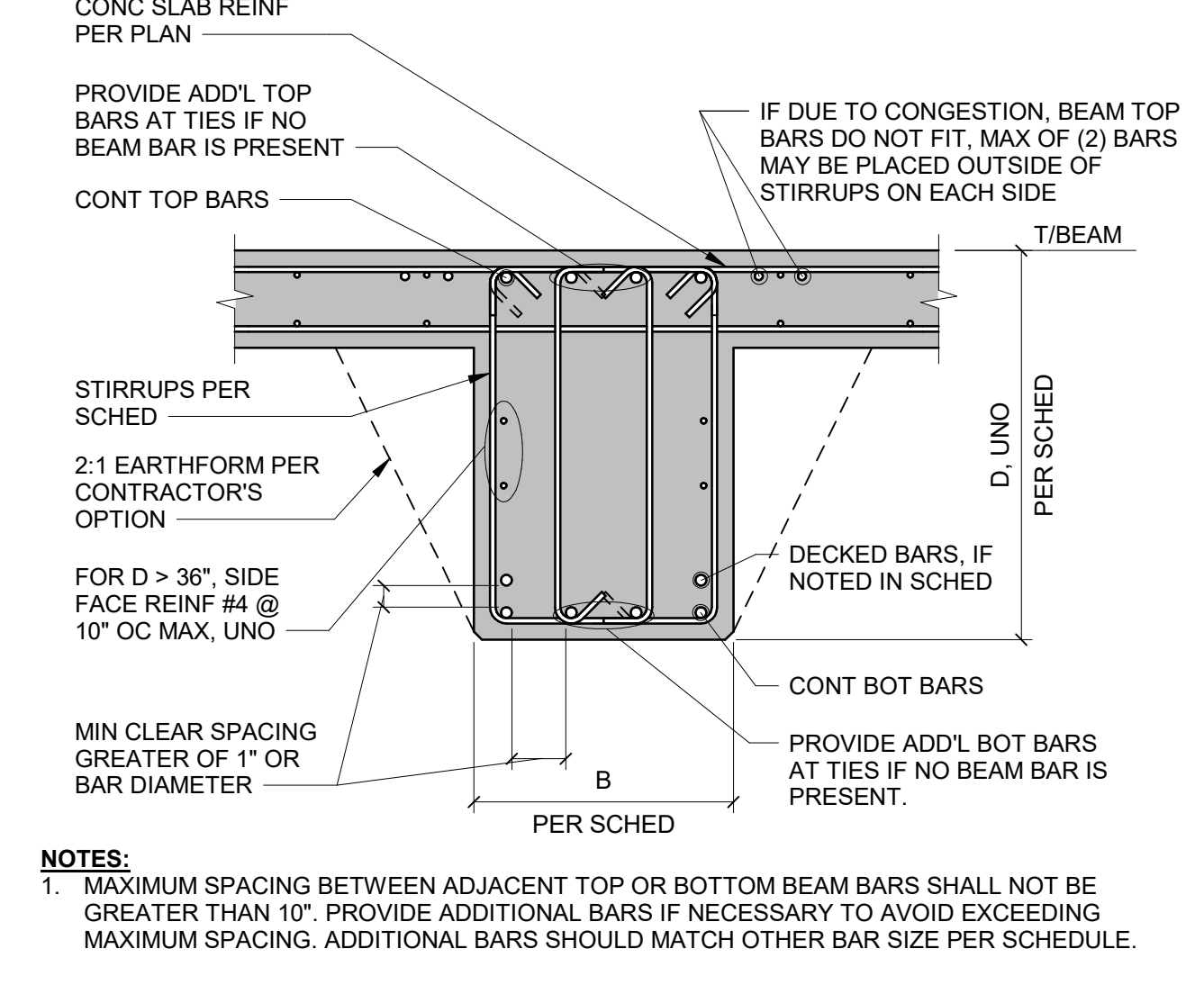

NOTES:

- FOR STIRRUP TYPES WITH CAP TIE, ALTERNATE SIDE OF CAP TIE WITH 135° HOOK AT BEAMS WITH SLAB ON ONE SIDE. LOCATE ALL 135° HOOKS TO SIDE WITH NO SLAB AT BEAMS WITHOUT SLAB ON EITHER SIDE. USE 135° HOOKS AT BOTH ENDS.

6 GRADE BEAM SCHEDULE
NO SCALE

8 TYP GRADE BEAM SECTION
NO SCALE

9 BEAM STIRRUPS AND TIES
NO SCALE

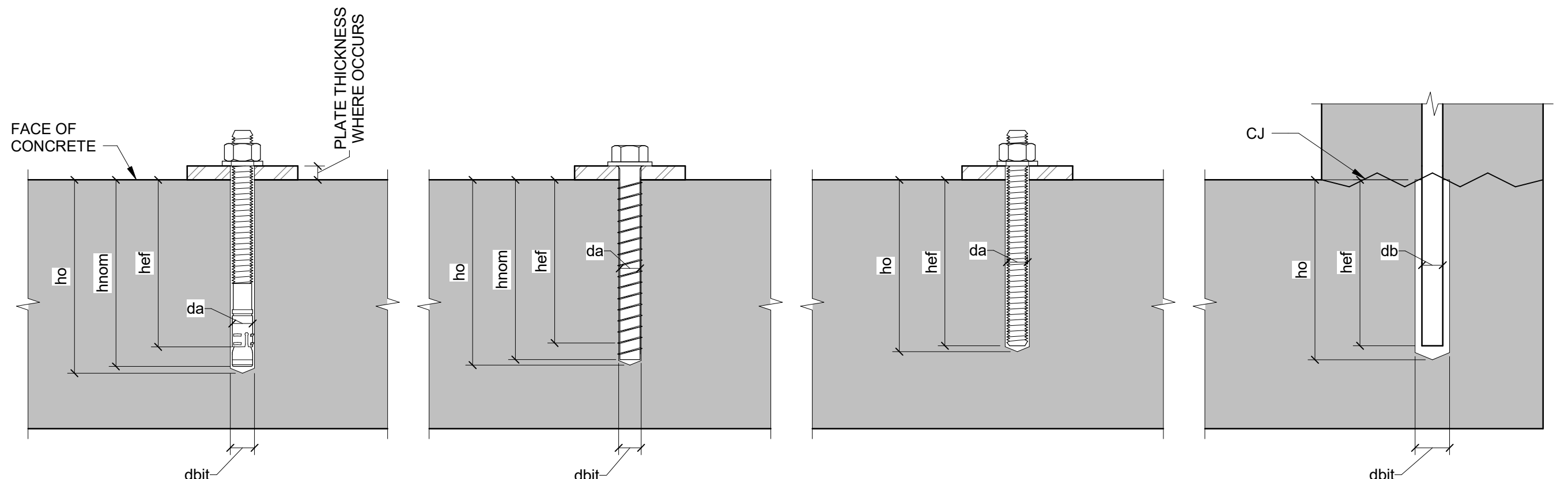

NOTES:

- REFER TO STRUCTURAL NOTES FOR APPROVED ANCHOR(S) AND EVALUATION REPORT(S).

ABBREVIATIONS

h_{eff} = EFFECTIVE EMBEDMENT PER DRAWINGS
h_{nom} = NOMINAL EMBEDMENT REQUIRED TO ACHIEVE EFFECTIVE EMBEDMENT PER EVALUATION REPORT. FOR EXPANSION ANCHORS, THIS APPLIES TO THE CONDITION PRIOR TO APPLICATION OF TORQUE.
h_o = MINIMUM HOLE DEPTH PER EVALUATION REPORT
da, db = DIAMETER OF ANCHOR/BAR PER DRAWINGS
dbt = DIAMETER OF DRILL BIT PER EVALUATION REPORT

11 TYPICAL POST-INSTALLED ANCHORS
NO SCALE

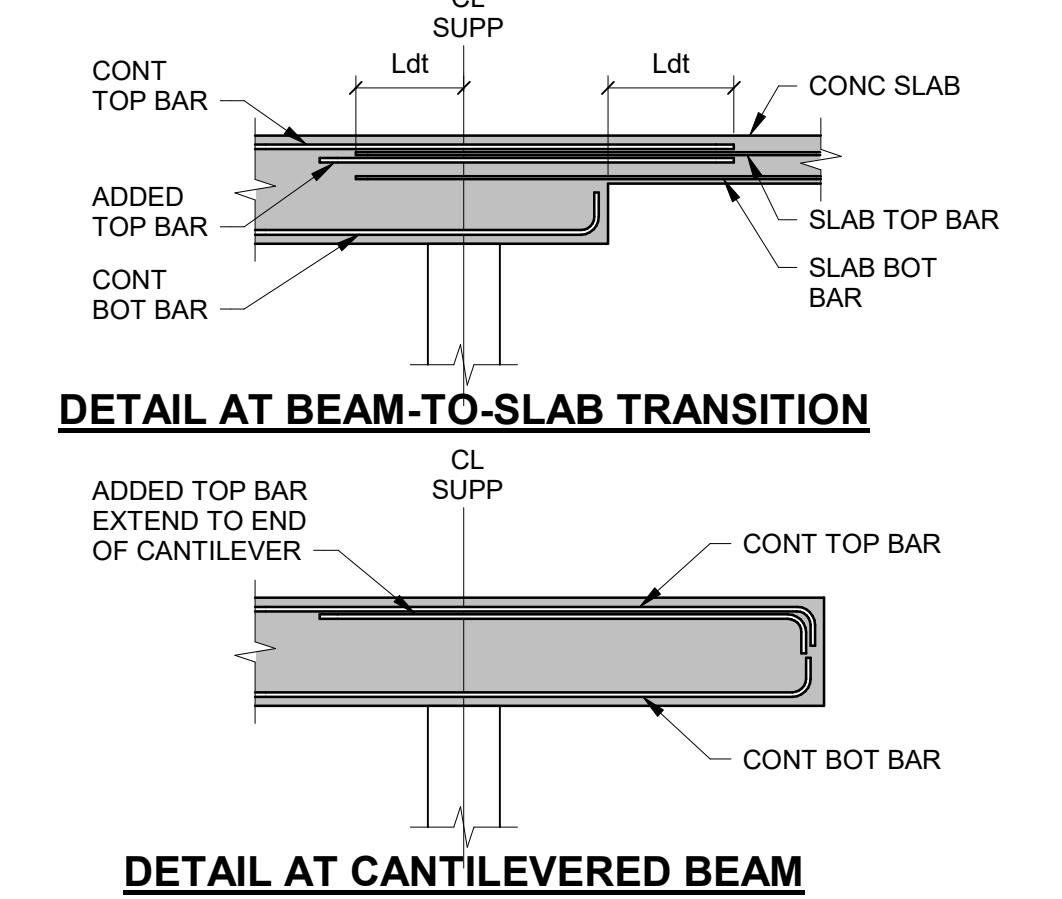
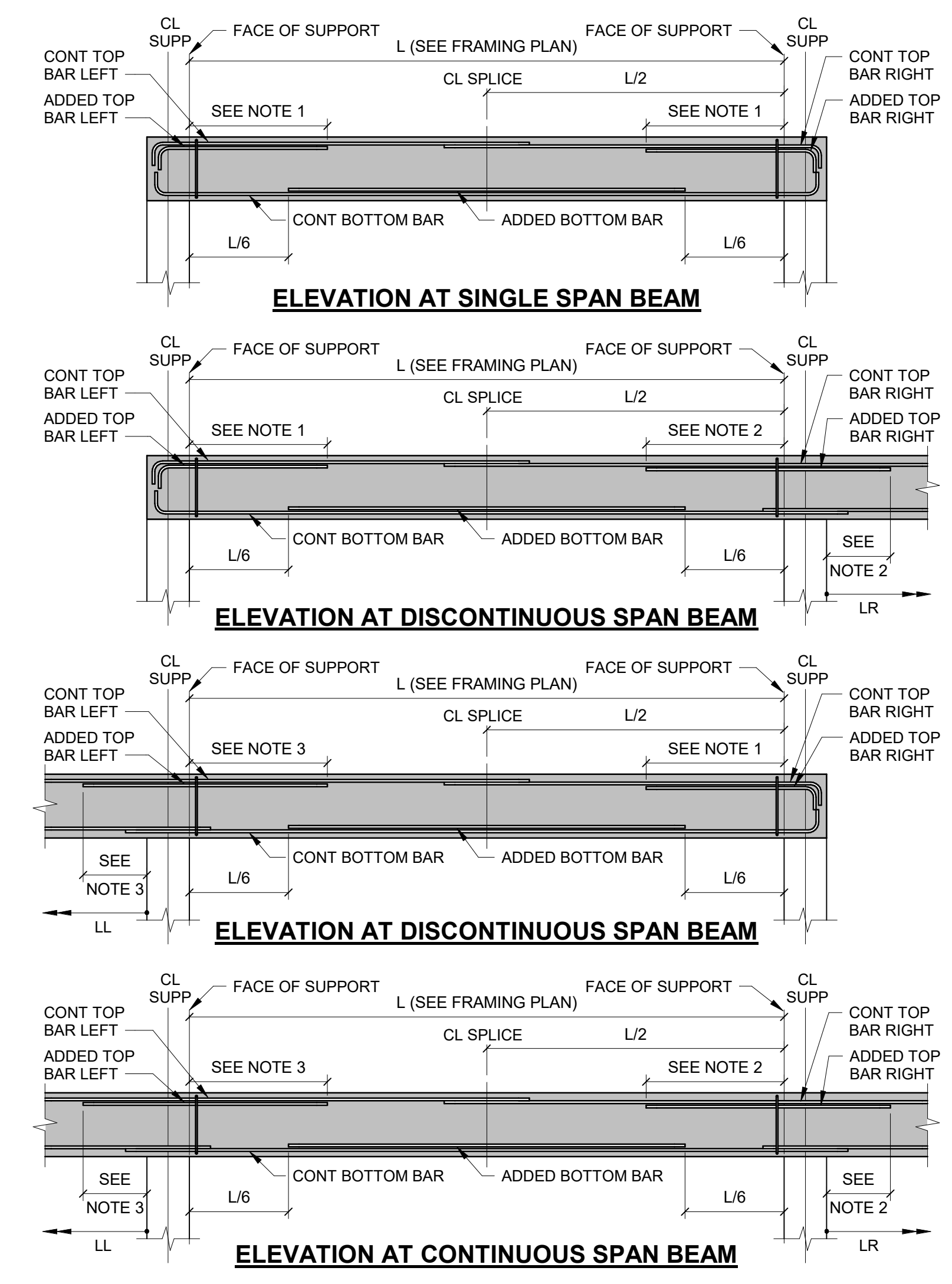

NOTES:

- GREATER OF L/3 AND 2'-6"
- GREATER OF L/3, L/3, AND 2'-6"
- GREATER OF L/3, L/3, AND 2'-6"
- SPlice CONTINUOUS TOP BARS L_h AND CONTINUOUS BOTTOM BARS L_b UNO.
- CANT BEAMS ARE CANTILEVERED: EXTEND TOP AND BOT BARS TO END OF CANTILEVER.
- SPLICE MAY BE OMITTED BY USING CONTINUOUS BAR IF LEFT AND RIGHT TOP BARS ARE SAME SIZE.
- MINIMUM OF (2) TOP AND (2) BOTTOM LONGITUDINAL BARS SHALL BE PLACED THROUGH EACH COLUMN.

19 TYP BEAM ELEVATIONS
NO SCALE

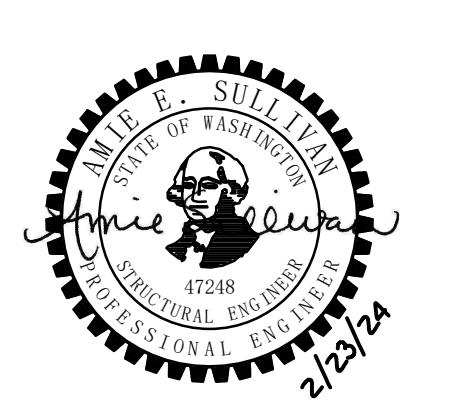

project engineer	CRU
project manager	JRS
drawn by	BMF
checked by	AES
job no.	220638

revisions:

no.	date	description

PERMIT
09/08/2023

TYPICAL CONCRETE DETAILS

CONTINUOUS FOOTING SCHEDULE							
TYPE MARK	DIMENSIONS		REINFORCING			PILE PIPE	
	WIDTH	DEPTH	TRANSVERSE	LONGITUDINAL	SCH 40 PIPE Ø	GAGE	LONGITUDINAL SPACING
FW2.5	2'-6"	1'-6"	-	-	6"	1'-6"	4'-0"
FW2.5A	2'-6"	2'-0"	-	-	-	-	SEE RETAINING WALL SCHEDULE
FW4.5	4'-6"	2'-0"	-	-	-	-	SEE RETAINING WALL SCHEDULE

NOTES:
1. SEE S/94.02 FOR TYPICAL FOOTING DETAIL.

1 CONTINUOUS FOOTING SCHEDULE
NO SCALE

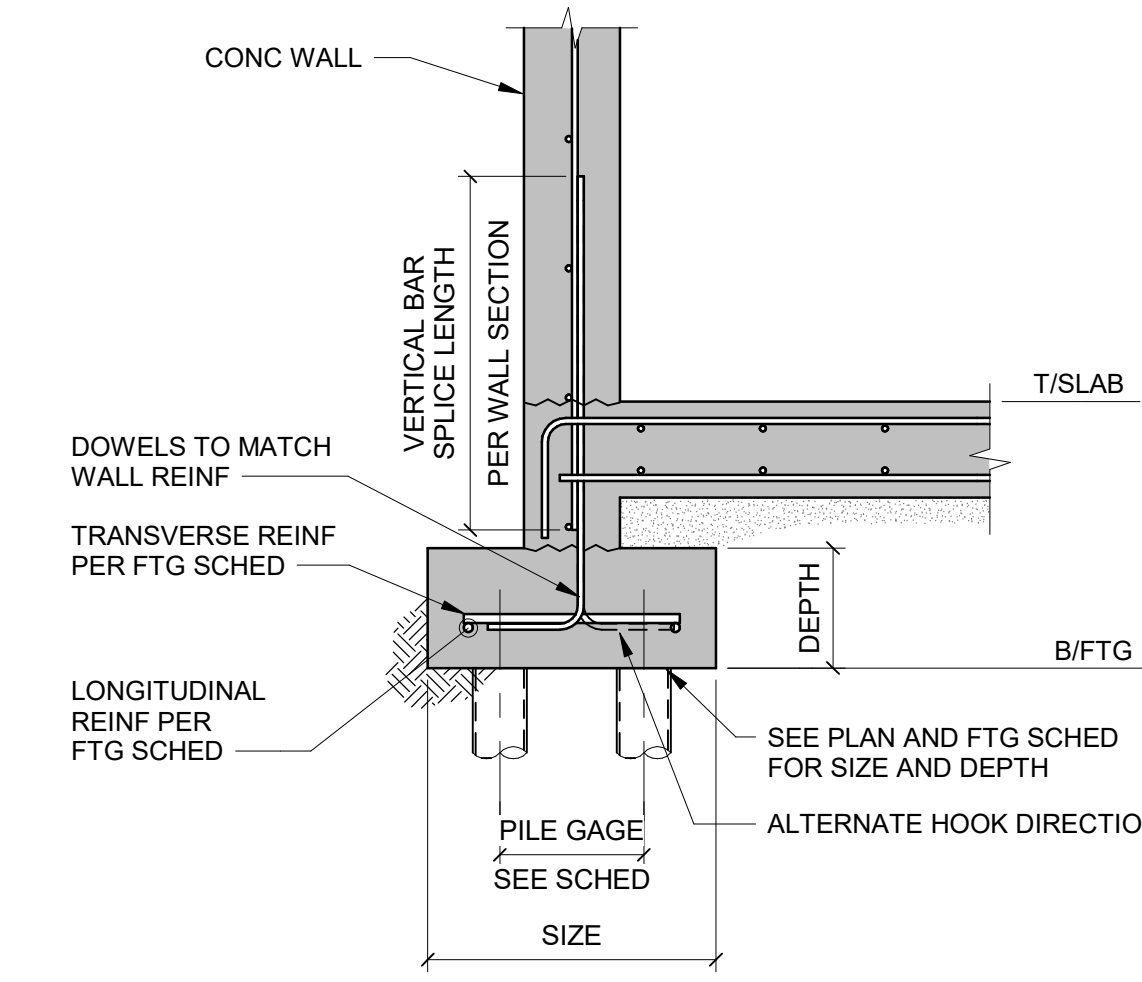

WALLS WITH SINGLE LAYER REINFORCING

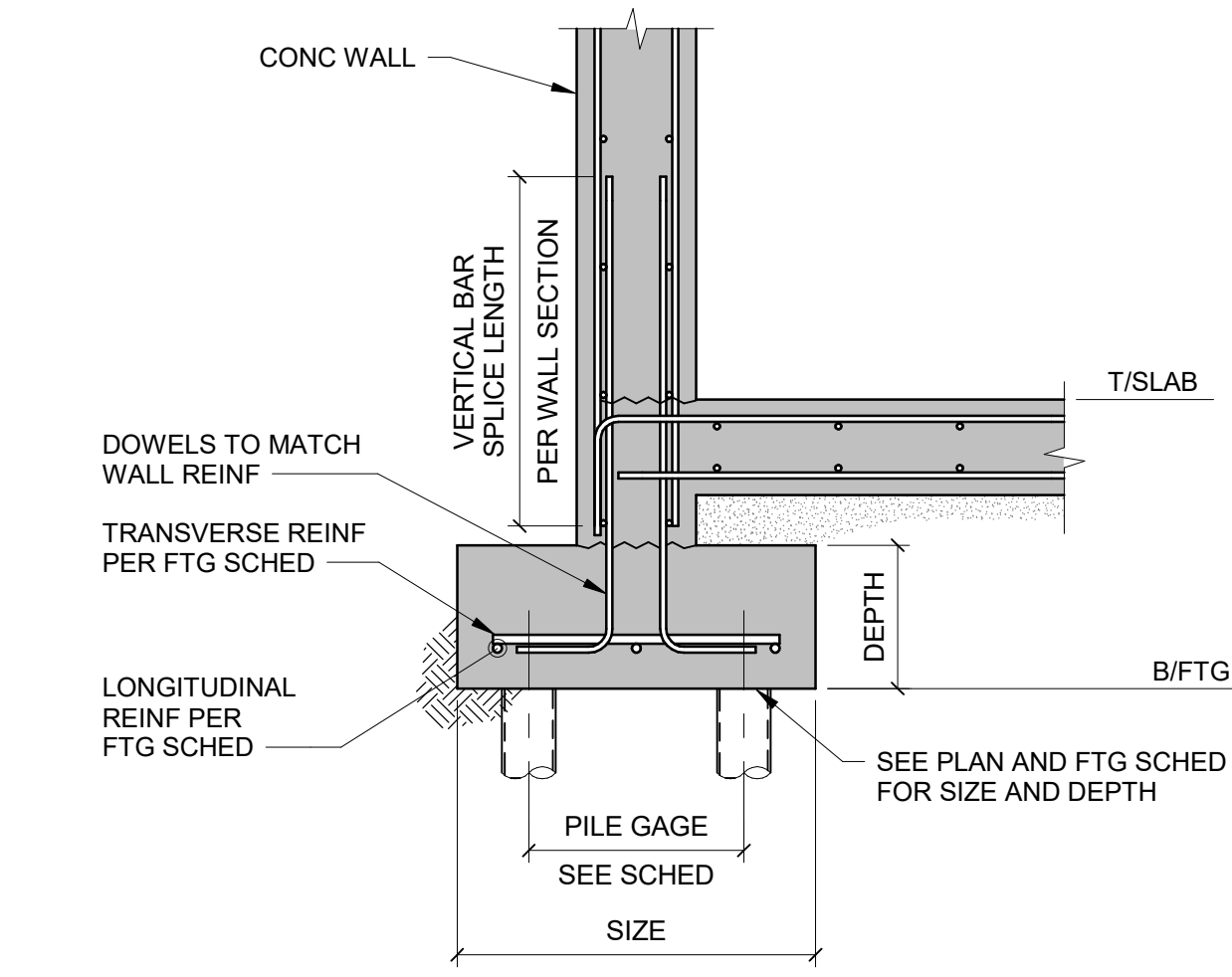

WALLS WITH DOUBLE LAYER REINFORCING

3 TYP EXTERIOR CONCRETE WALL FOOTING
NO SCALE

CANTILEVERED RETAINING WALL SCHEDULE																
H	DIMENSIONS					REINFORCING					PILE PIPE					
	tw	W	D	P	A BARS	B BARS	C BARS	D BARS	E BARS	F BARS	G BARS	J BARS	K BARS	SCH 40 PIPE Ø	PILE PIPE A LONGITUDINAL SPACING	PILE PIPE B LONGITUDINAL SPACING
UP TO 8'-0"	10"	2'-6"	2'-0"	0'-10"	#6 @ 12" OC	#6 @ 12" OC	#4 @ 18" OC				#4 @ 18" OC	#6 @ 12" OC	#6 @ 12" OC	6"	8'-0"	4'-0"
8'-0" TO 13'-0"	12"	4'-6"	2'-0"	1'-9"	#7 @ 9" OC	#7 @ 9" OC	#4 @ 18" OC				#4 @ 18" OC	#7 @ 12" OC	#7 @ 12" OC	6"	6'-0"	2'-0"

6 CANTILEVERED RETAINING WALL SCHEDULE
NO SCALE

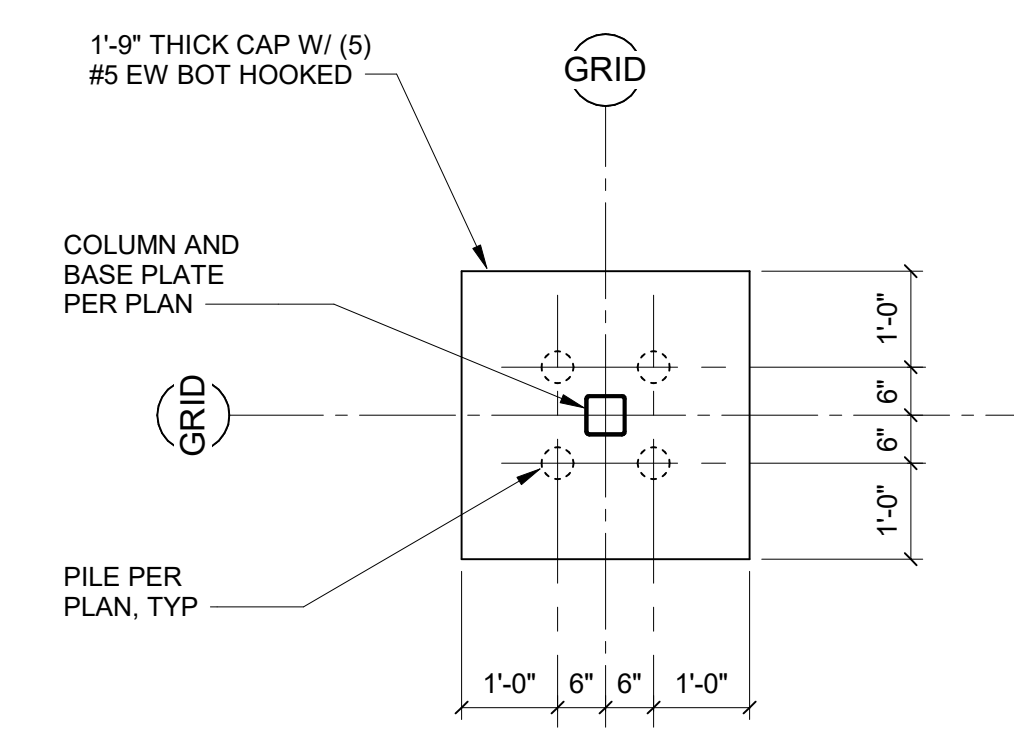

8 PILE CAP PC-4 PLAN
NO SCALE

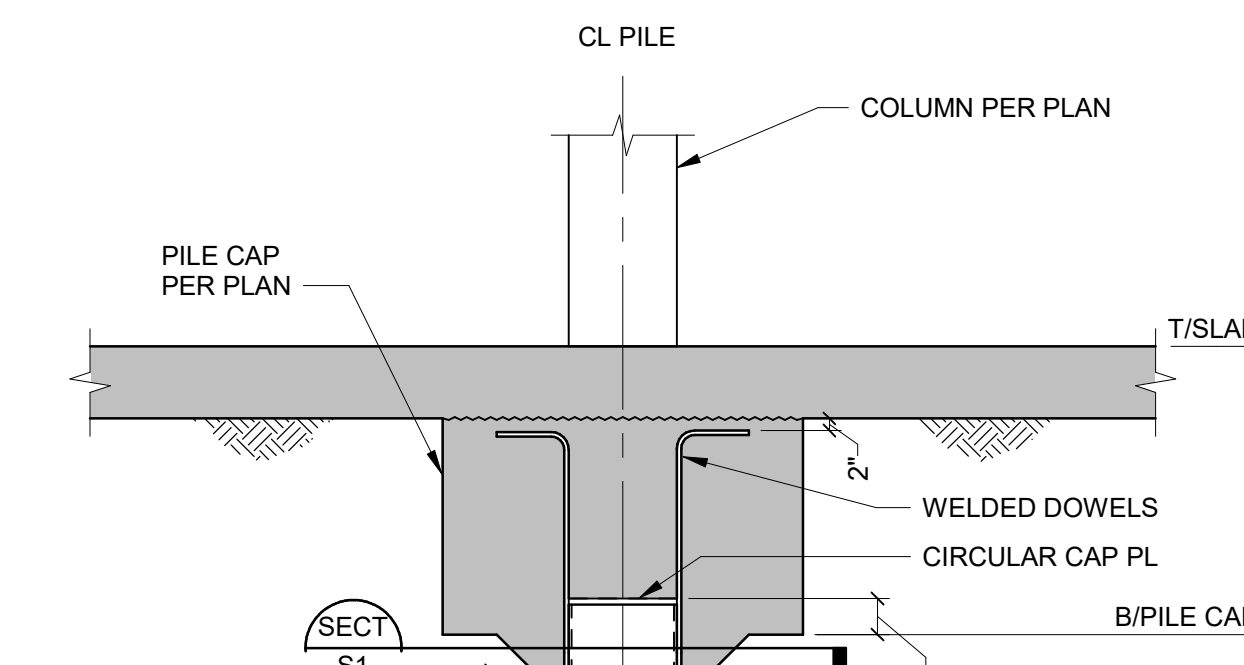

14 STEEL PIPE PILE DETAIL **TYPE S1**
NO SCALE

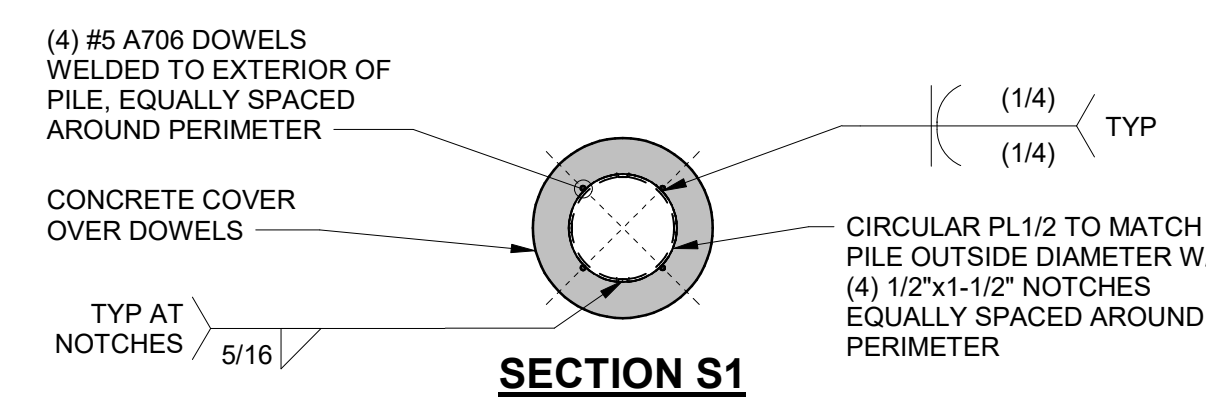

14 STEEL PIPE PILE DETAIL **TYPE S1**
NO SCALE

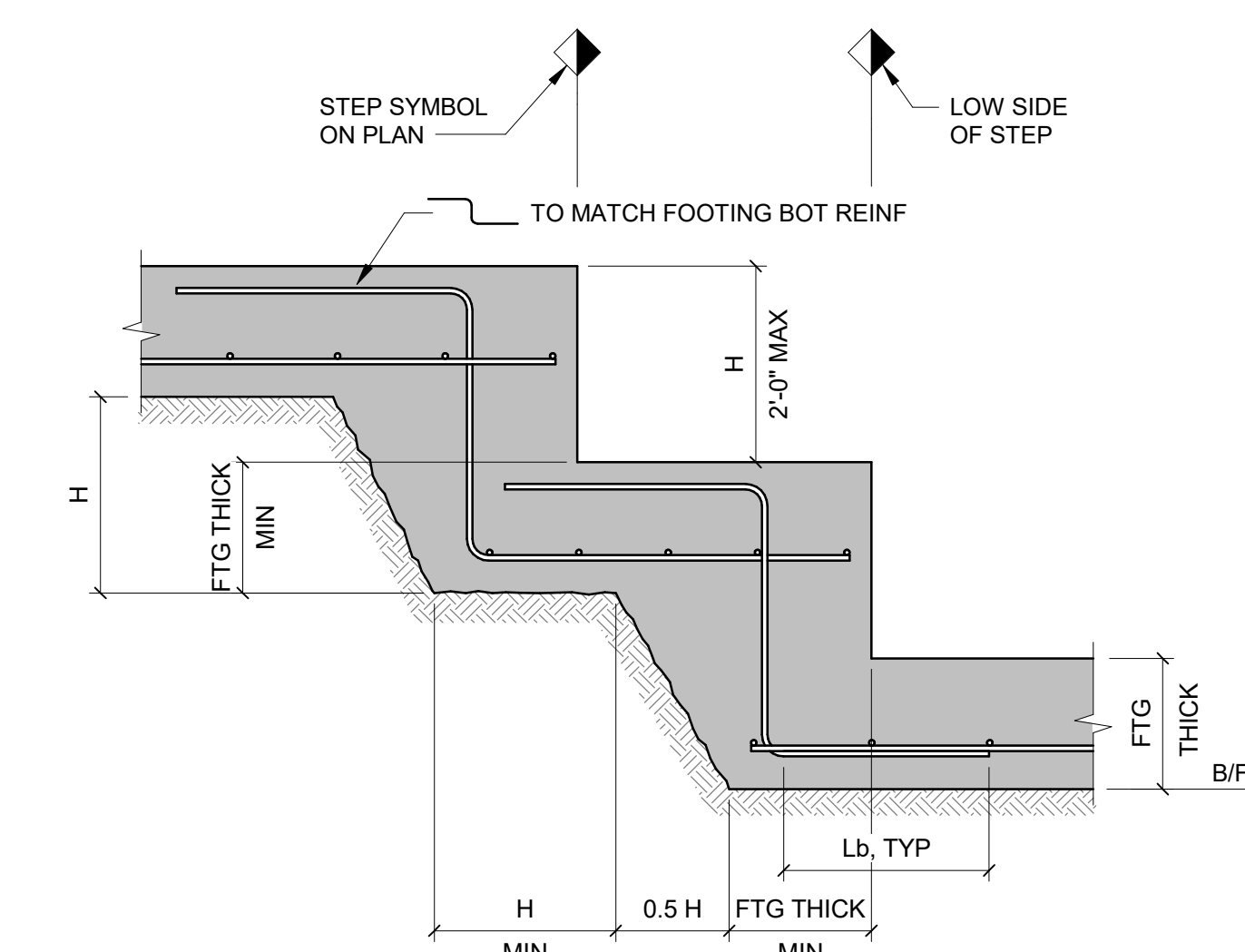

19 TYP STEPPED FOOTING DETAIL
NO SCALE

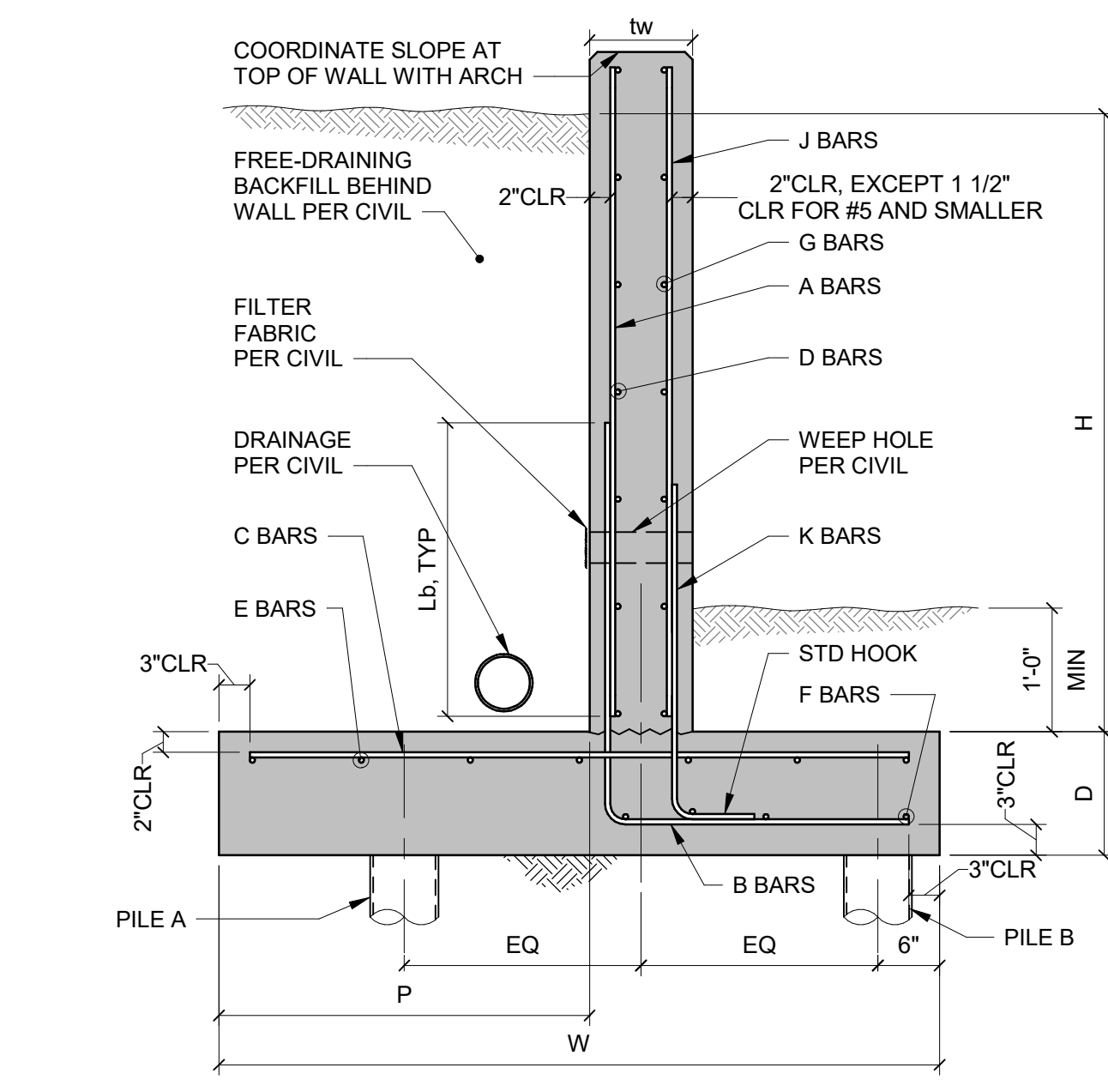

NOTES:
1. B BARS EXTEND TO TOP OF WALL WHERE A BARS ARE NOT INDICATED.
2. K BARS EXTEND TO TOP OF WALL WHERE J BARS ARE NOT INDICATED.
3. VERTICAL CONTROL JOINTS WITH 1/2" PREMOULDED JOINT FILLER SHALL BE SPACED AT 15'-0" MAXIMUM.

5 CANTILEVERED RETAINING WALL DETAIL
NO SCALE

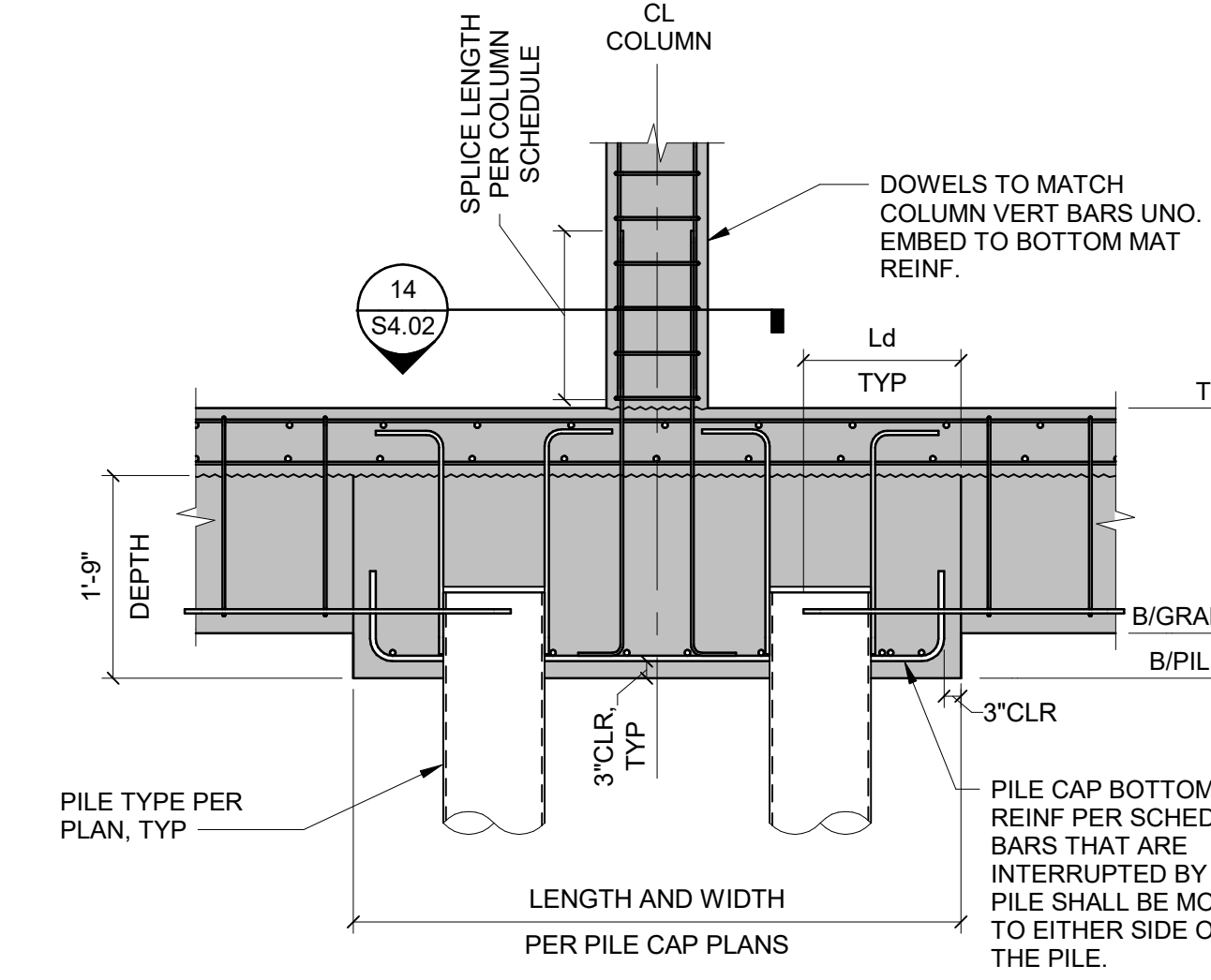

10 TYP PILE CAP SECTION
NO SCALE

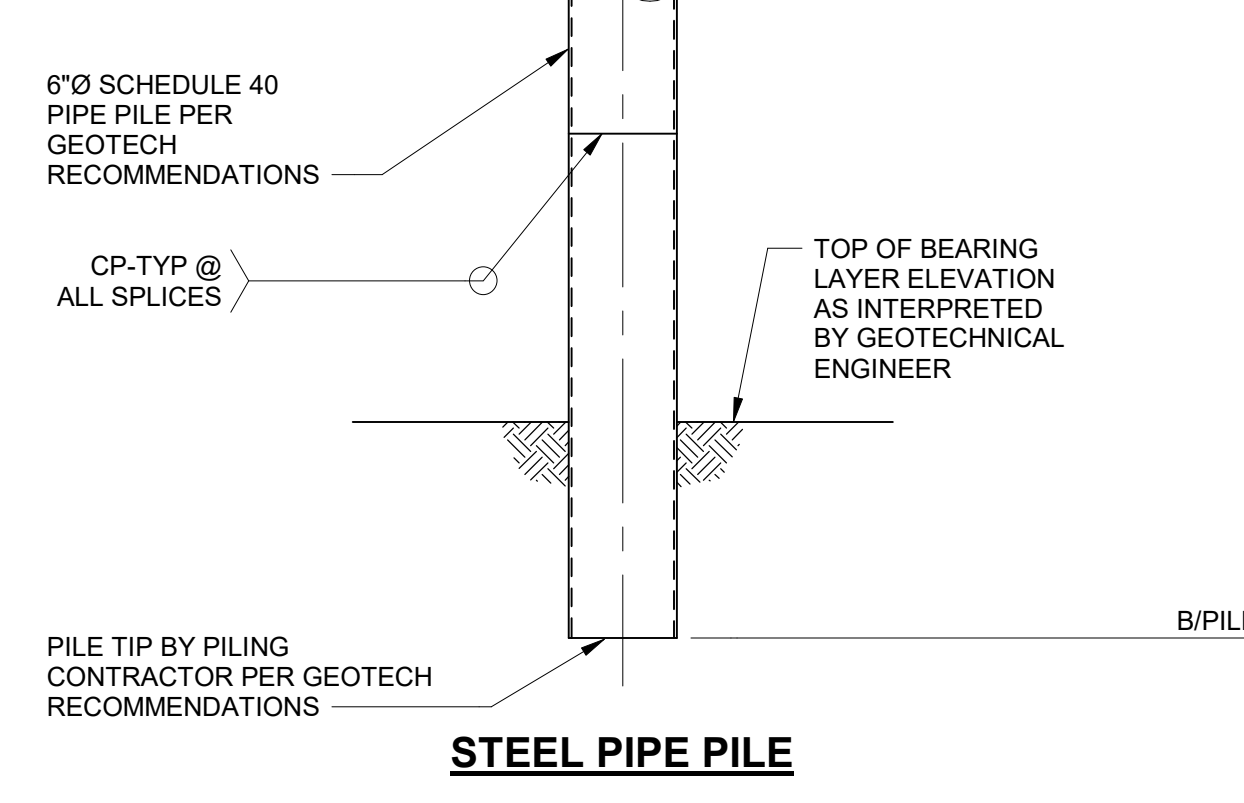

14 STEEL PIPE PILE DETAIL **TYPE S1**
NO SCALE

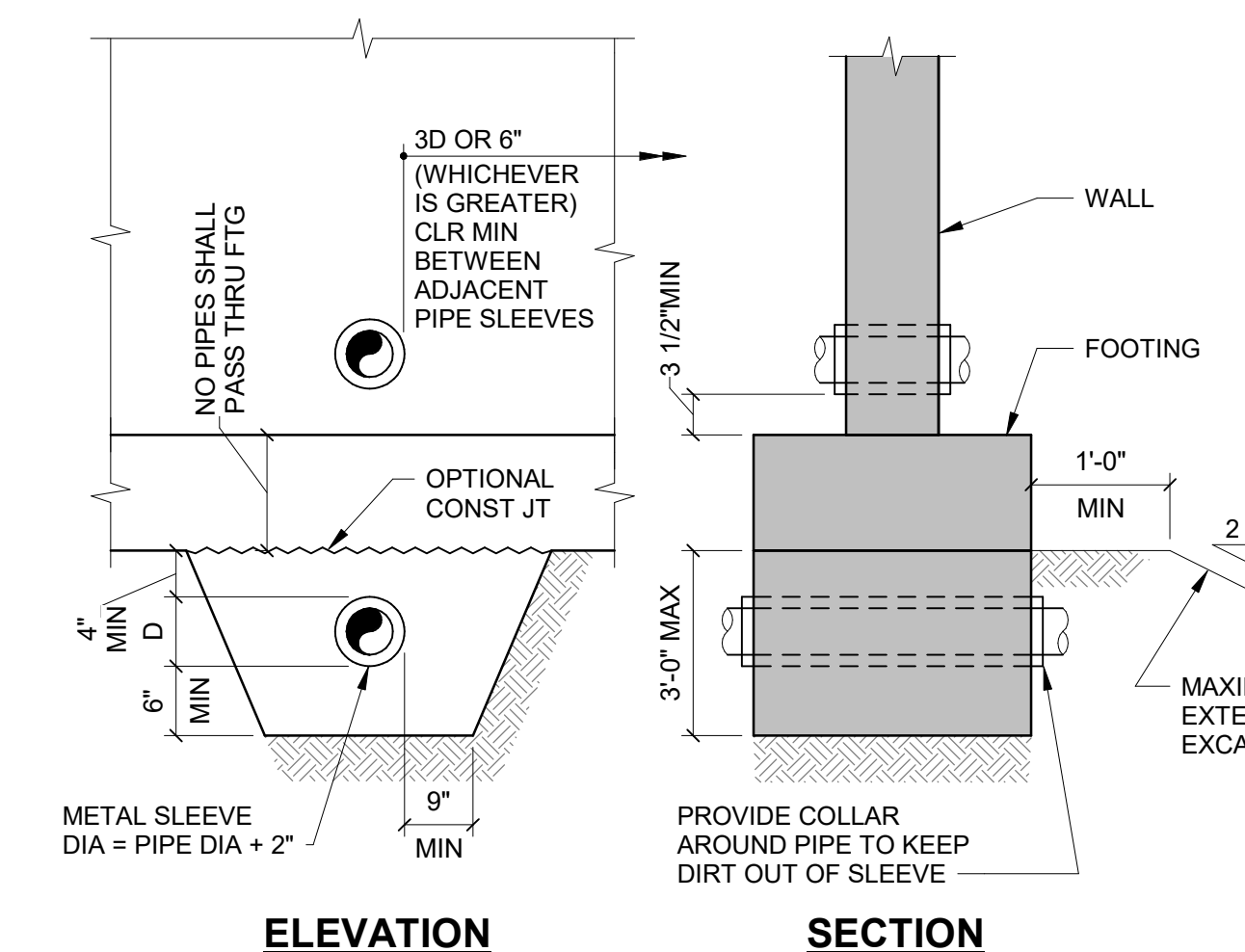

NOTES:
1. STEP FOOTING PER TYPICAL STEPPED FOOTING DETAIL AS REQUIRED TO SATISFY THESE CONDITIONS.
2. GENERAL CONTRACTOR TO COORDINATE EXACT DEPTH AND LOCATION OF PIPE.
3. "D" SHALL NOT EXCEED 6".

20 TYP DETAIL OF PIPE AT FOOTINGS
NO SCALE



stamp: seal



1601 Fifth Avenue, Suite 1600
Seattle, WA 98101
206.622.5822
kpff.com

project engineer: CRL
project manager: JRS
drawn by: BMF
checked by: AES
job no.: 220638

revisions:
no. date description:

PERMIT
09/08/2023

TYPICAL CONCRETE DETAILS
sheet: S4.02

CONNECTION NOTES:

- ALL BOLTED CONNECTIONS TO BE TYPE N WITH FULLY PRETENSIONED ASTM A325-N BOLTS PER AISC STANDARDS EXCEPT WHERE "SLUG TIGHT", "FINGER TIGHT" OR "SLIP CRITICAL" CONNECTIONS ARE INDICATED.
- BOLTS IN BEAM TO BEAM CONNECTIONS MAY BE TIGHTENED TO AISC "SLUG TIGHT" CONDITION UPON APPROVAL OF ENGINEER AND OWNER.
- CONNECTIONS TO HAVE AISC STANDARD ROUND HOLES EXCEPT AS NOTED OTHERWISE.
- BEAM CONNECTIONS TO BE PER THE STANDARD BOLTED BEAM CONNECTION DETAIL UNLESS NOTED OTHERWISE.
- [S] SHOWN ON PLANS INDICATES NUMBER OF BOLTS REQUIRED IF DIFFERENT FROM NUMBER OF BOLTS REQUIRED USING 3/5S.01
- [SE] SHOWN ON PLANS INDICATES NUMBER OF BOLTS REQUIRED IN A DOUBLE ANGLE EMBEDDED PLATE CONNECTION. SEE 11/5S.01
- [FH] SHOWN ON PLANS INDICATES FULL HEIGHT STIFFENER PLATE REQUIRED. SEE
- ALTERNATE CONNECTION DETAILS MAY BE SUBMITTED TO THE ENGINEER FOR REVIEW AND SHALL BE ACCOMPANIED BY CALCULATIONS BEARING THE SEAL AND SIGNATURE OF THE WASHINGTON STATE STRUCTURAL ENGINEER WHO IS RESPONSIBLE FOR THE DESIGN. ALTERNATE CONNECTIONS SHALL HAVE EQUAL OR GREATER CAPACITY THAN THE CONNECTIONS SHOWN ON THE DRAWINGS.
- FOR MEMBERS DESIGNATED AS PART OF THE SFPS, WELD TABS SHALL BE REMOVED UPON COMPLETION AND COOLING OF THE WELD, AND THE ENDS OF THE WELD SHALL BE MADE SMOOTH AND FLUSH WITH THE EDGES OF ABUTTING PARTS.

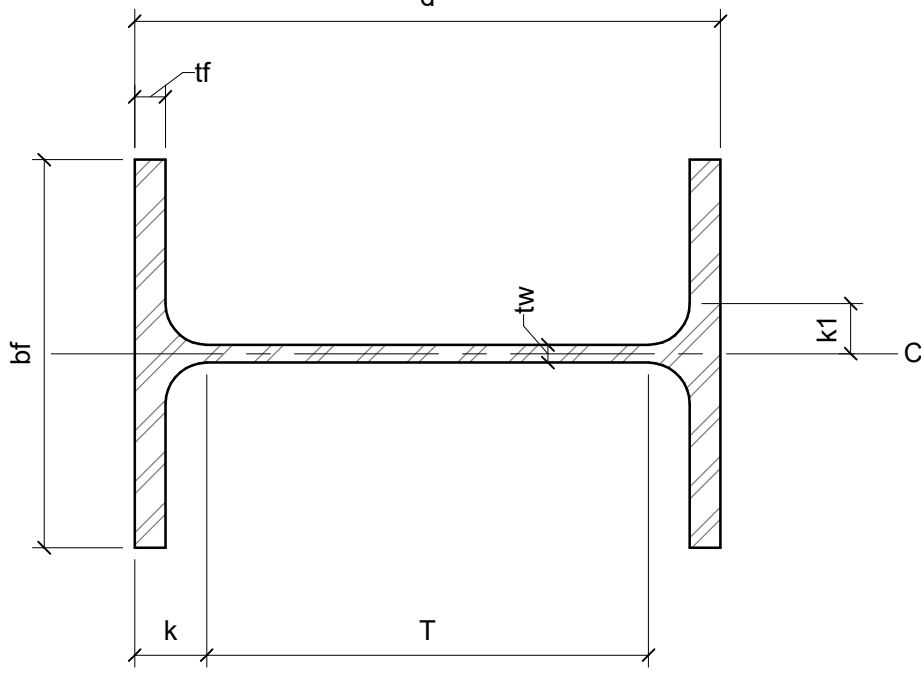

BEAM TO COLUMN

- NOTES:**
1. SHORT SLOTTED HOLES MAY BE USED AT ALL COLUMN CONNECTIONS AS AN OPTION.

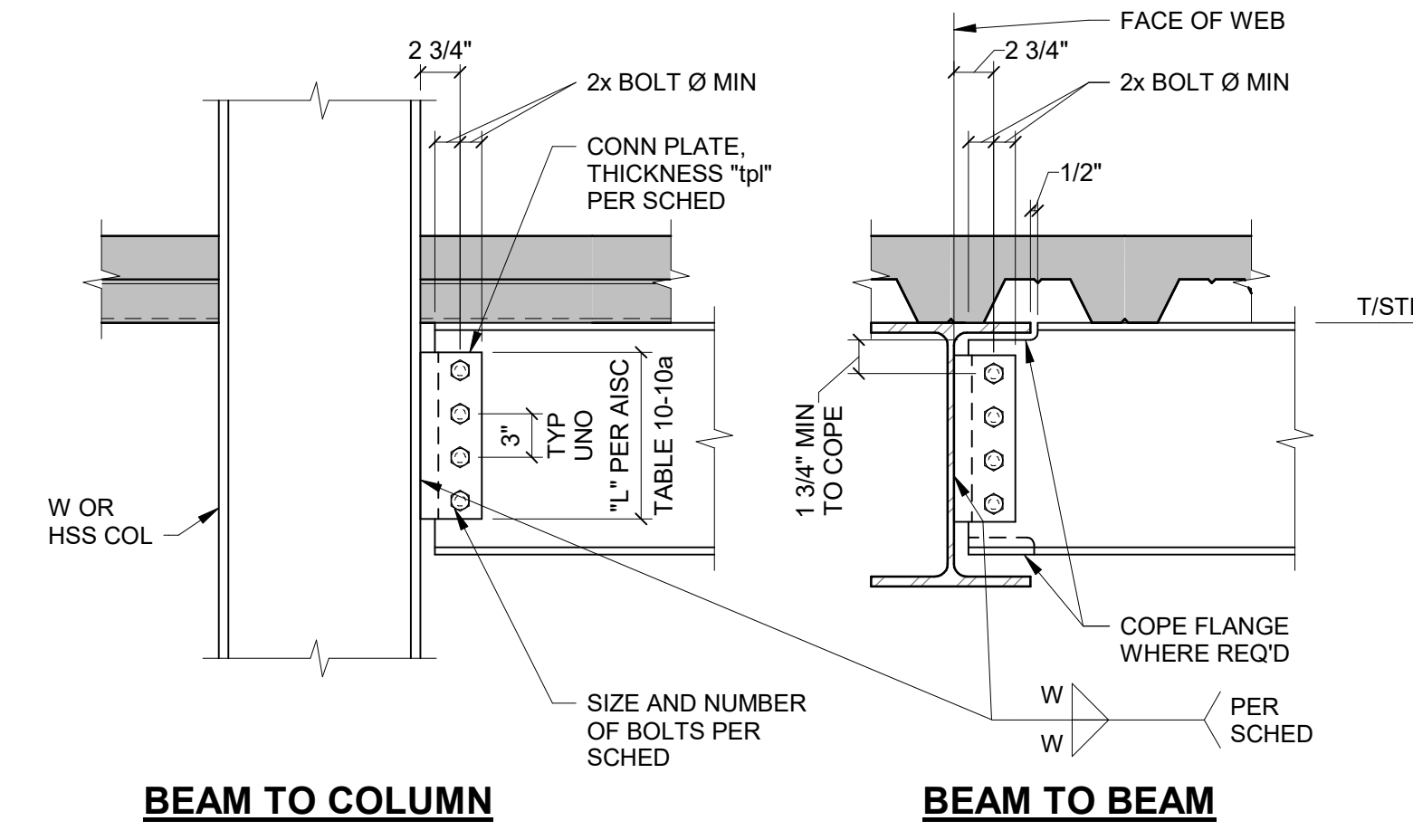

BEAM TO BEAM

BEAM SIZE	NUMBER AND SIZE OF BOLTS REQUIRED	MIN PLATE THICKNESS "TPL"	WELD SIZE "W"
W6, C4, C6, C7	(2) 3/4" @ 2" GA	1/4"	3/16"
W8, C8, C9	(2) 3/4"	1/4"	3/16"
W10, C10	(2) 3/4"	1/4"	3/16"
W12, C12	(3) 3/4"	1/4"	3/16"
W14, C15	(3) 3/4"	1/4"	3/16"
W16	(4) 3/4"	1/4"	3/16"
W18	(4) 3/4"	5/16"	1/4"
W21	(5) 3/4"	5/16"	1/4"
W24	(6) 3/4"	5/16"	1/4"
W27	(7) 3/4"	5/16"	1/4"
W30	(8) 1/2"	3/8"	1/4"
W33	(9) 1/2"	1/2"	5/16"
W36	(10) 1/2"	1/2"	5/16"
W40	(11) 1/2"	1/2"	5/16"
W44	(12) 1/2"	1/2"	5/16"

1 TYP CONNECTION NOTES
NO SCALE

2 TYP ABBREVIATIONS
NO SCALE

3 TYP STANDARD BOLTED BEAM CONN (3/4" AND 1" DIAMETER BOLTS)
NO SCALE

TYPE MARK	NUMBER OF BOLTS REQUIRED	PLATE SIZE	NUMBER OF HORIZ ROWS OF STUDS	NUMBER OF STUDS PER ROW, N	STUD SPACING		MIN STUD LENGTH	DOUBLE ANGLE SIZE	MIN CONC THICKNESS	MIN EDGE DISTANCE
					X	Y				
2E	2	PL5/8x10x0'-11"	2	2	7"	7"	5"	L5x3-1/2x5/16	8"	0'-8"
3E	3	PL5/8x11x1'-2"	3	2	8"	5"	5"	L5x3-1/2x5/16	8"	0'-10"
4E	4	PL5/8x14x1'-5"	3	2	11"	6 1/2"	6"	L5x3-1/2x5/16	9"	1'-0"
5E	5	PL3/4x15x1'-8 1/2"	4	2	12"	5 1/2"	6"	L5x3-1/2x5/16	9"	2'-0"
6E	6	PL3/4x15x2'-2"	5	2	12"	5 1/2"	6"	L5x3-1/2x5/16	9"	2'-4"
7E	7	PL1/2x18x2'-4"	5	3	7 1/2"	6"	8"	L5x5x5/16	11"	2'-10"
8E	8	PL1/2x12x2'-0"	5	3	9"	6 1/2"	8"	L5x5x5/16	11"	3'-2"
9E	9	PL1/2x4x3'-8"	6	3	10 1/2"	8"	8"	L5x5x5/16	11"	4'-8"
10E	10	PL1/2x4x4'-4"	7	3	10 1/2"	8"	8"	L5x5x5/16	11"	5'-2"

- NOTES:**
1. BOLTS TO BE FINGER TIGHT, JAMB NUT. DO NOT TIGHTEN FULLY.
2. BOLT DIAMETERS TO BE SAME AS SHOWN ON STANDARD BOLTED BEAM CONNECTION SCHEDULE.
3. TYPICAL WALL REINFORCING NOT SHOWN FOR CLARITY.
4. LENGTH OF WELD RETURN NOT TO EXCEED 1" TO LIMIT FIXITY.

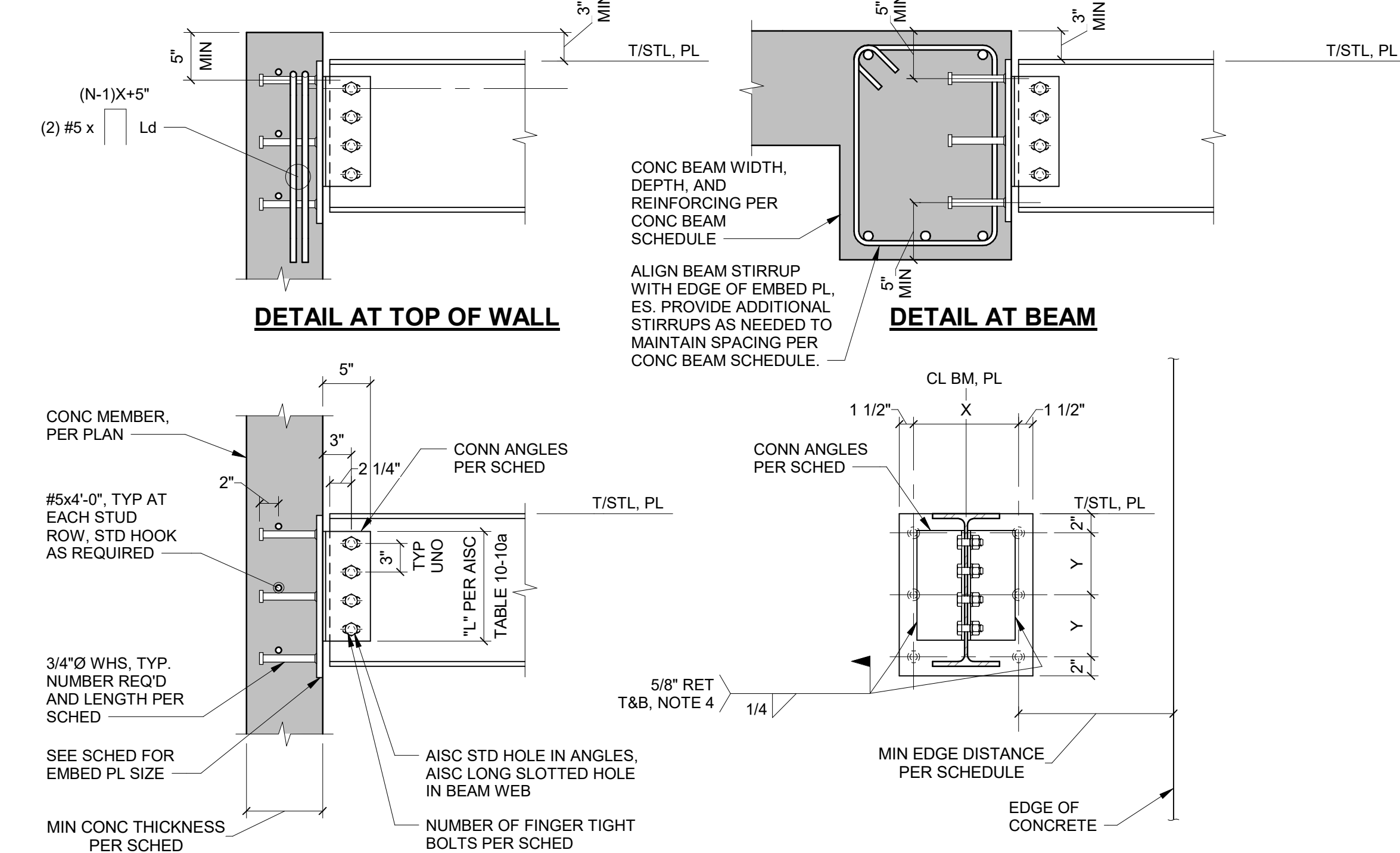

DETAIL AT TOP OF WALL

DETAIL AT BEAM

11 TYP EMBEDDED PLATE CONNECTION
NO SCALE

8 TYP CONNECTIONS FOR BEAMS AT DIFFERENT ELEVATION CONDITIONS
NO SCALE

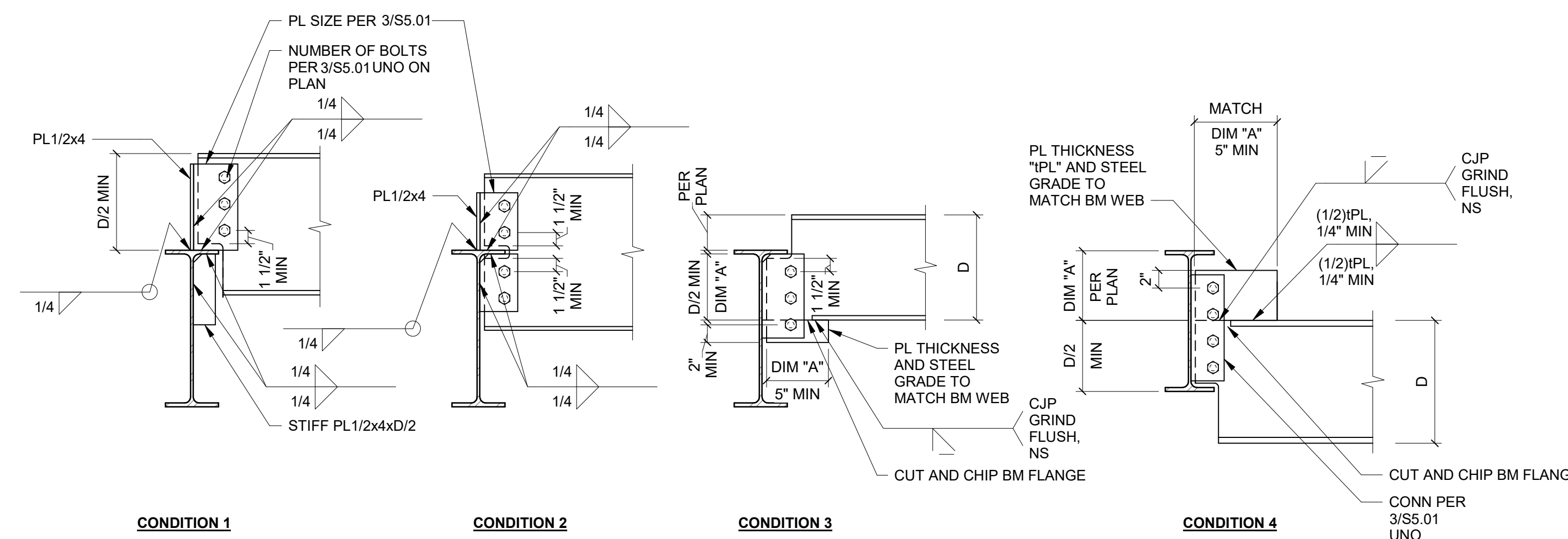

CONDITION 1

CONDITION 2

CONDITION 3

CONDITION 4

10 TYP BEAM PENETRATIONS
NO SCALE

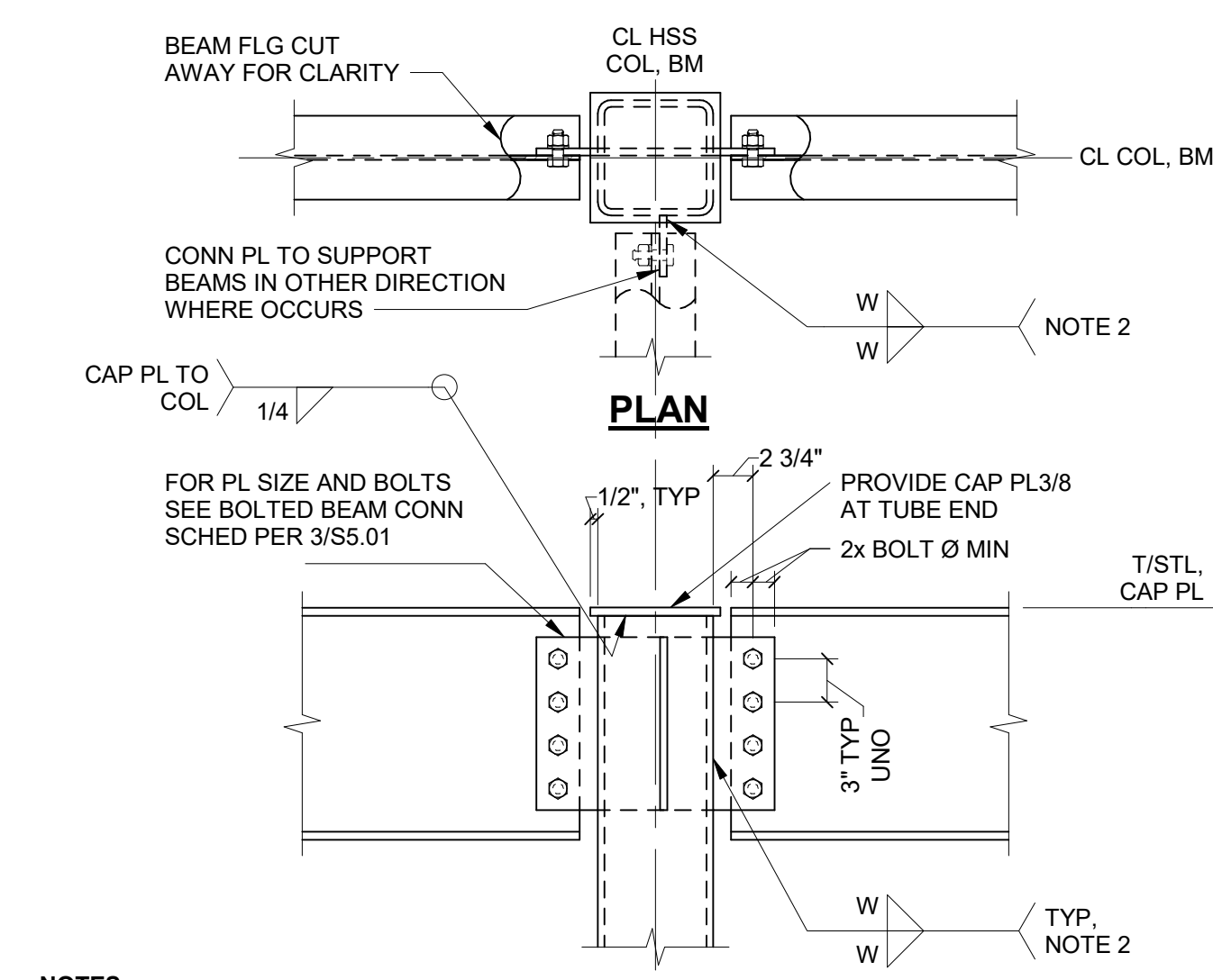

- NOTES:**
1. WHERE SINGLE BEAM CONNECTION IS REQUIRED ON THROUGH-PLATE, EXTEND PLATE 1/2" PAST EXTERIOR FACE OF COLUMN FOR WELD ACCESS.
2. WELD SIZE "W" PER BOLTED BEAM SCHEDULE. SEE 3/5S.01

15 THROUGH-PLATE TO HSS COLUMN TOP
NO SCALE

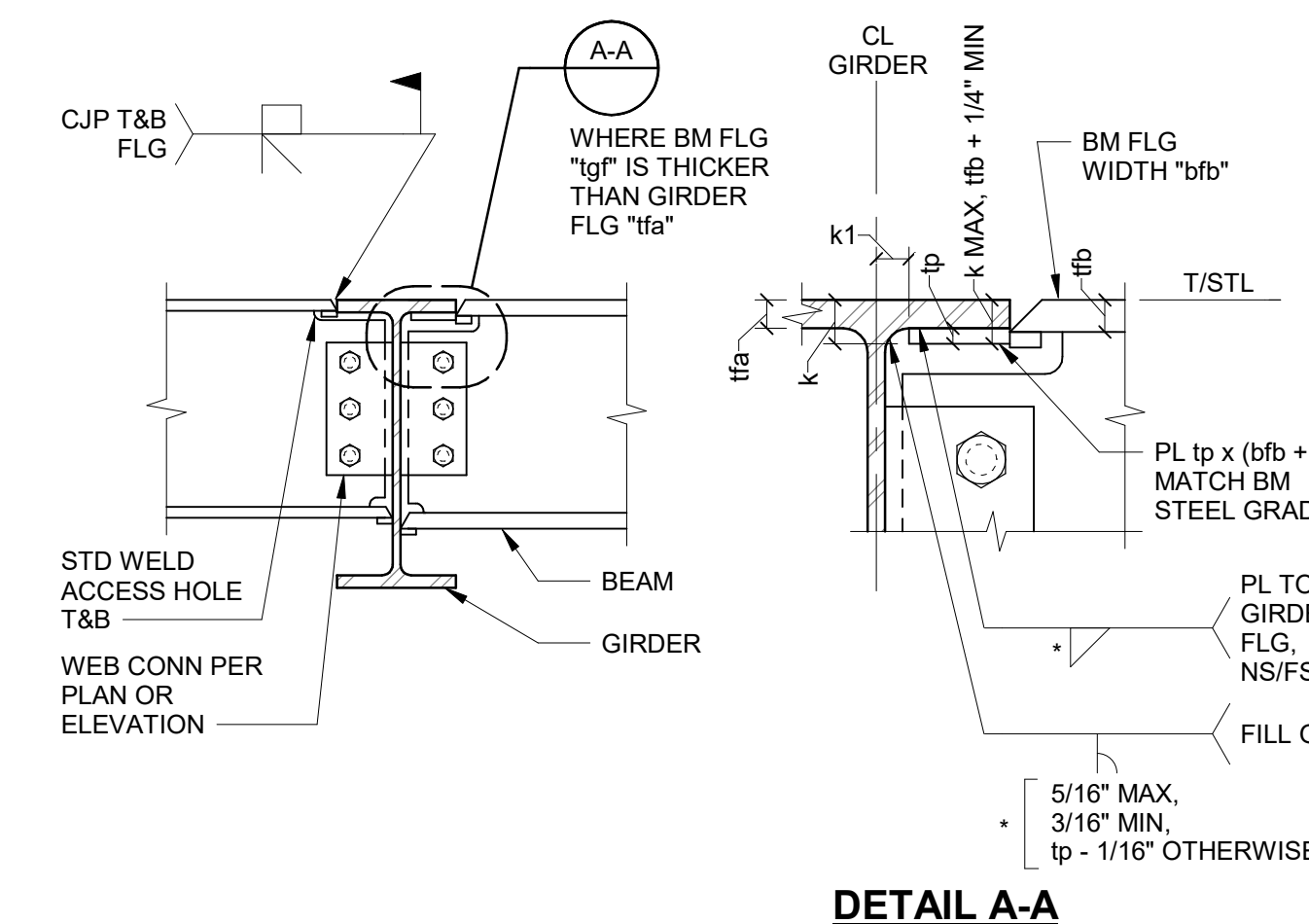

- NOTES:**
1. USE WHERE INDICATED BY \rightarrow ON PLAN.
2. PLATE THICKNESS "tp" DEFINED BY REQUIRED TOTAL BUILT-UP BEAM FLANGE THICKNESS DIMENSION TO THE NEAREST 1/16", BUT NOT LESS THAN 1/4".

20 TYP MOMENT DRAG STRUT CONN TO BEAM
NO SCALE

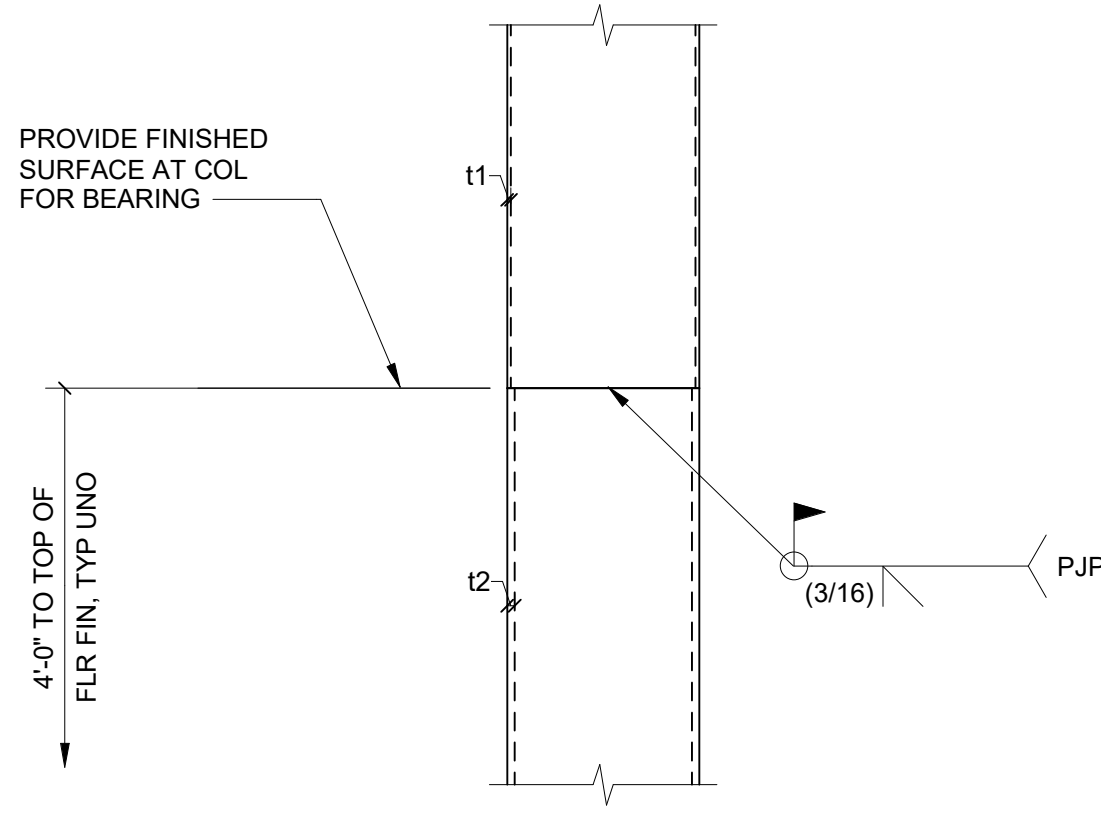

- NOTES:**
1. PROVIDE ERECTION AIDS AS REQUIRED.

18 TYPICAL HSS COLUMN SPLICE
NO SCALE

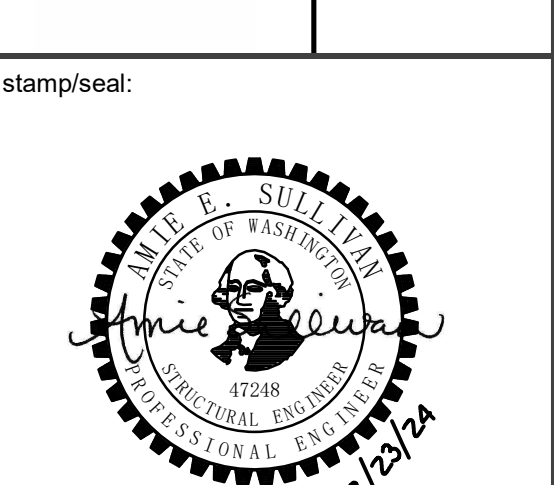

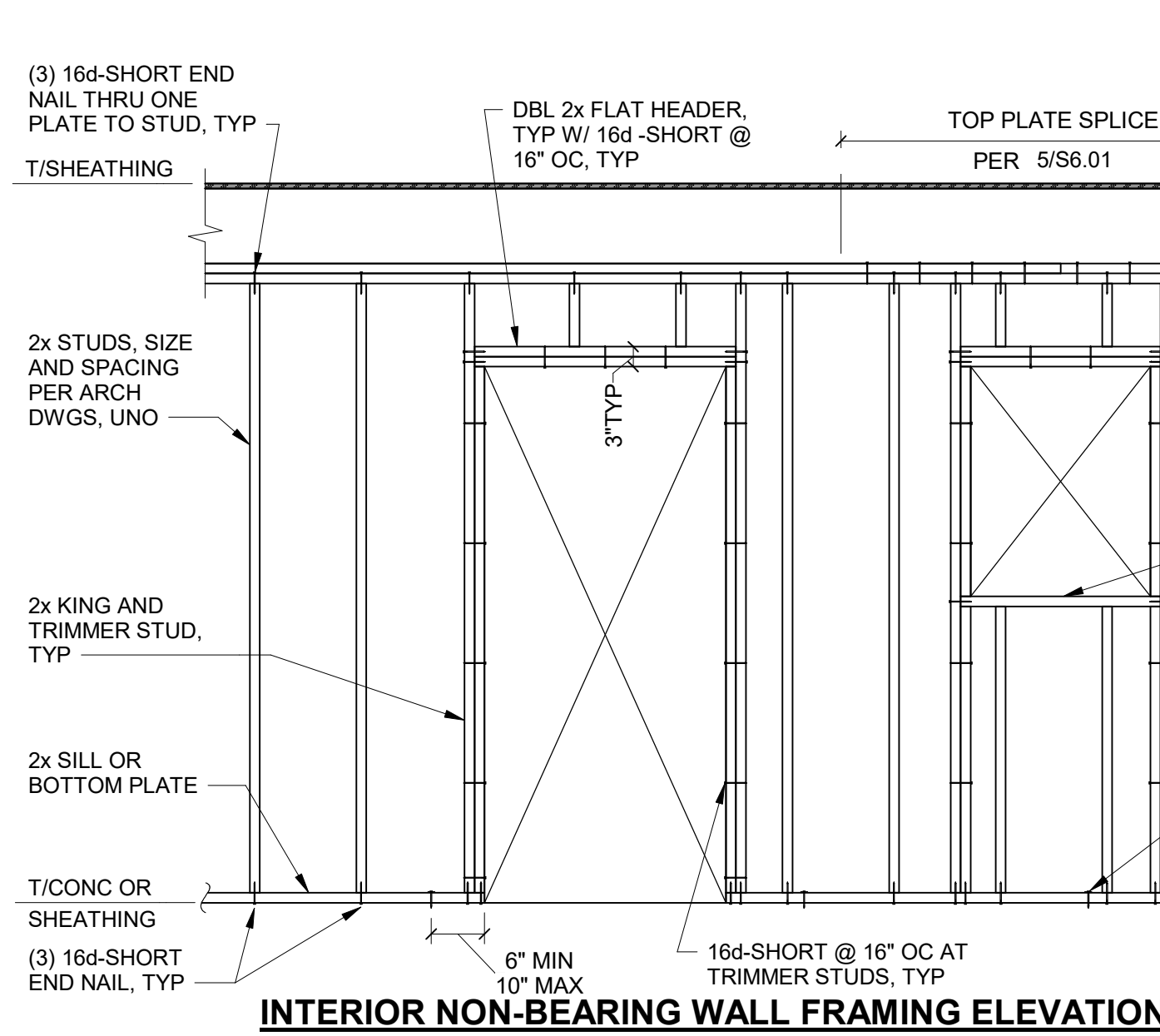

INTERIOR NON-BEARING WALL FRAMING ELEVATION

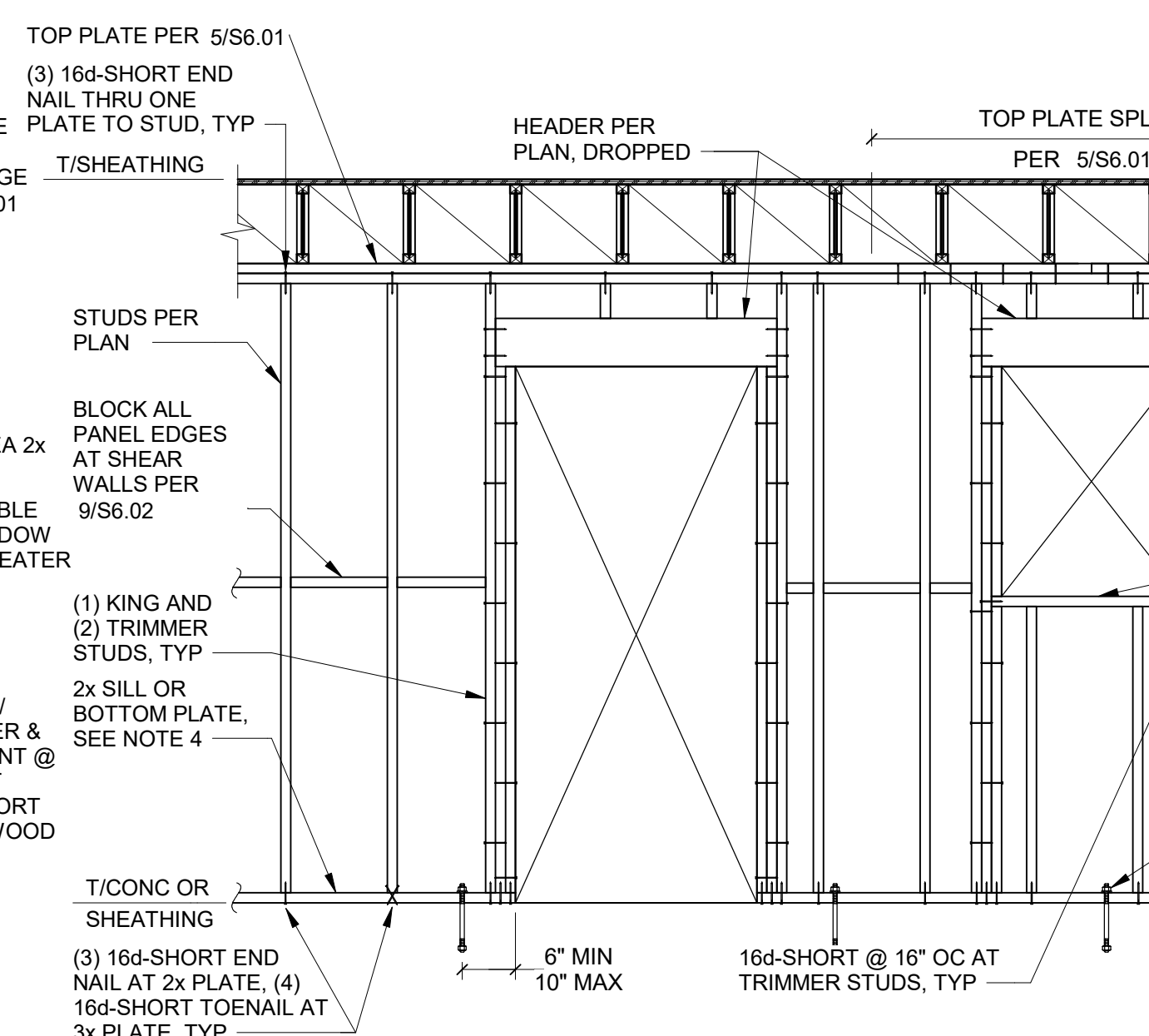

INTERIOR BEARING WALL FRAMING ELEVATION

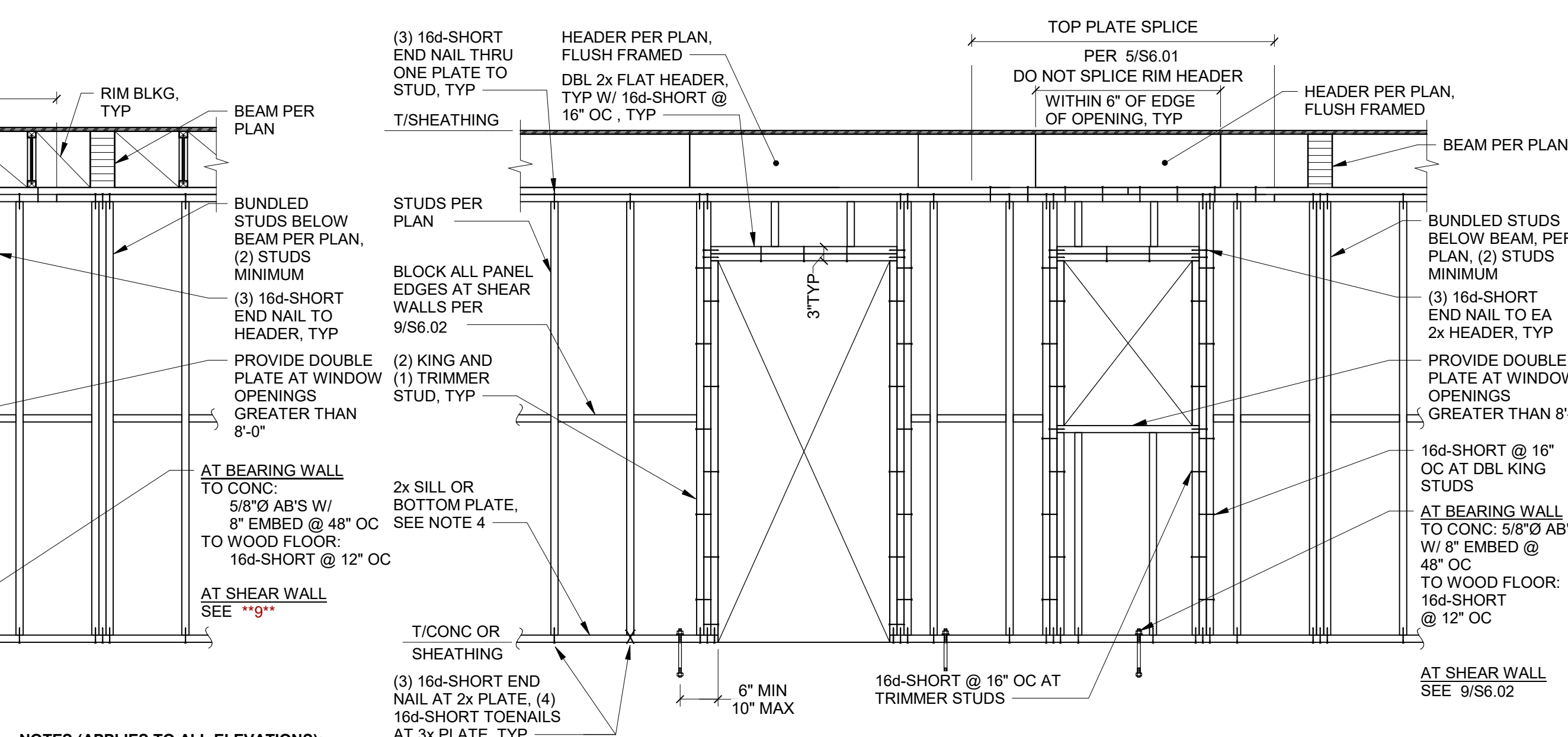

EXTERIOR WALL FRAMING ELEVATION

- NOTES (APPLIES TO ALL ELEVATIONS):**
- FRAMING NAILING NOT SHOWN SHALL BE AS INDICATED IN IBC TABLE 2304.10.1
 - SILL PLATES TO BE PRESSURE-TREATED WHERE IN CONTACT WITH CONCRETE
 - SEE 6/56.02 FOR SILL BOLT CONSTRUCTION
 - INCREASE SILL PLATE SIZE TO 3x WHERE REQUIRED BY SHEAR WALL SCHEDULE PER 6/56.02

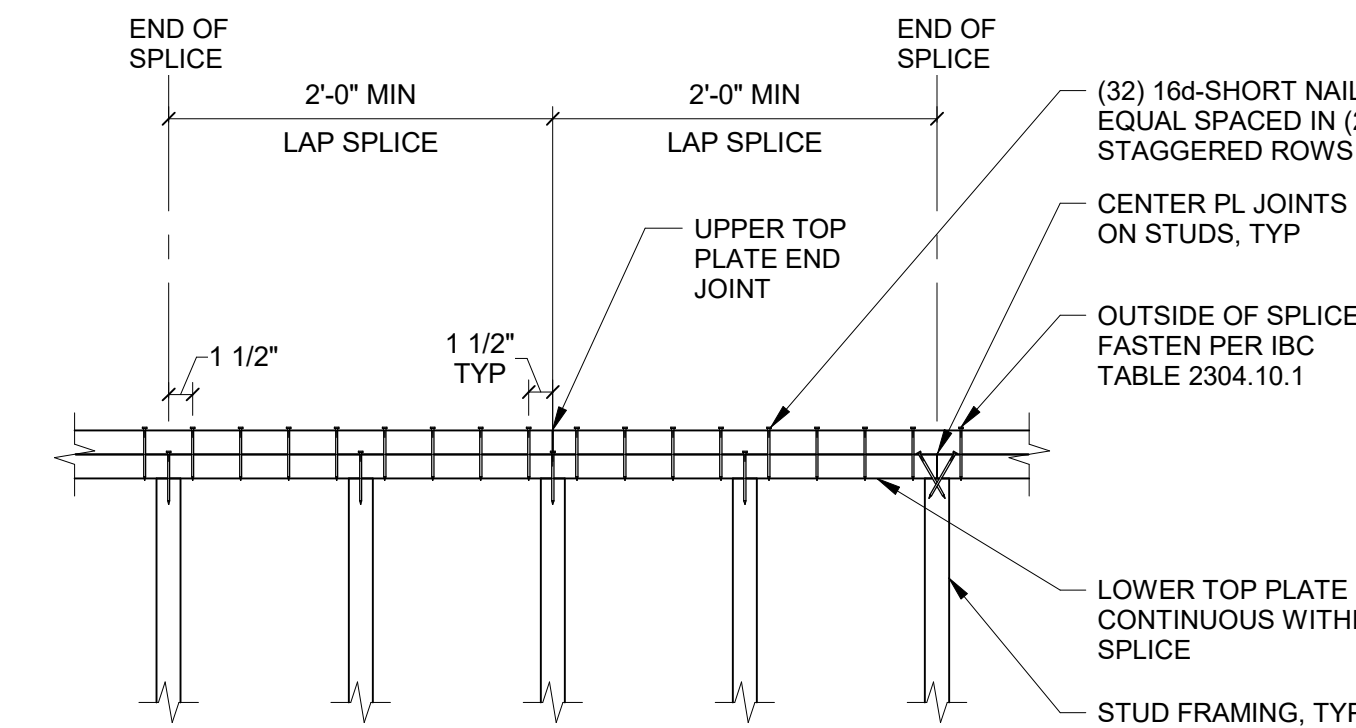

- NOTES:**
- PROVIDE ONE-HALF OF FASTENERS WITHIN THE SPLICE ON EACH SIDE OF THE TOP PLATE END JOINT
 - PROVIDE CONTINUOUS TOP PLATES WITHOUT JOINTS WHERE WALLS ARE 12'-0" OR LESS IN LENGTH

1 TYP STUD WALL FRAMING ELEVATION

NO SCALE

5 TYP TOP PLATE SPLICE

NO SCALE

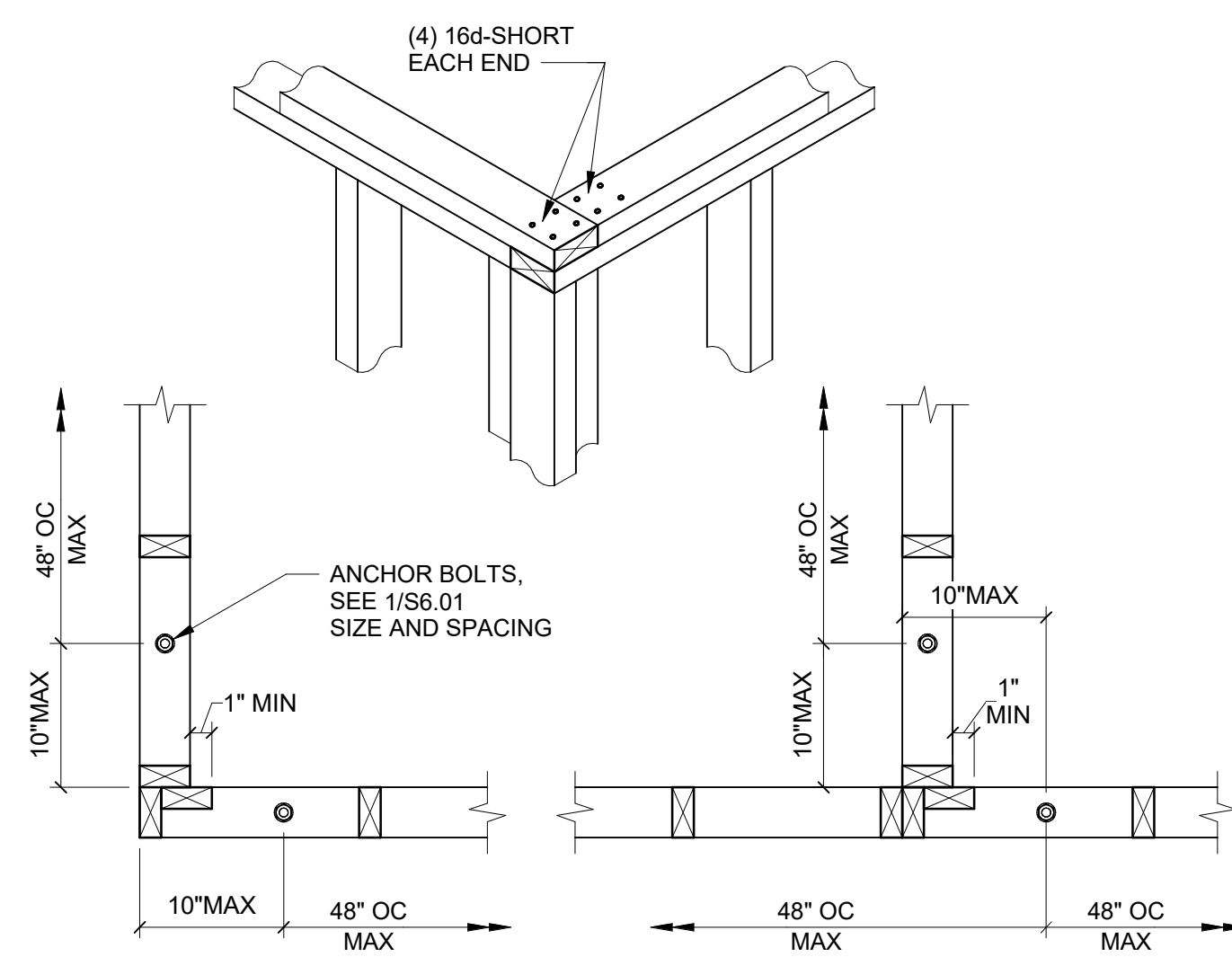

6 TYP STUD WALL CORNER

NO SCALE

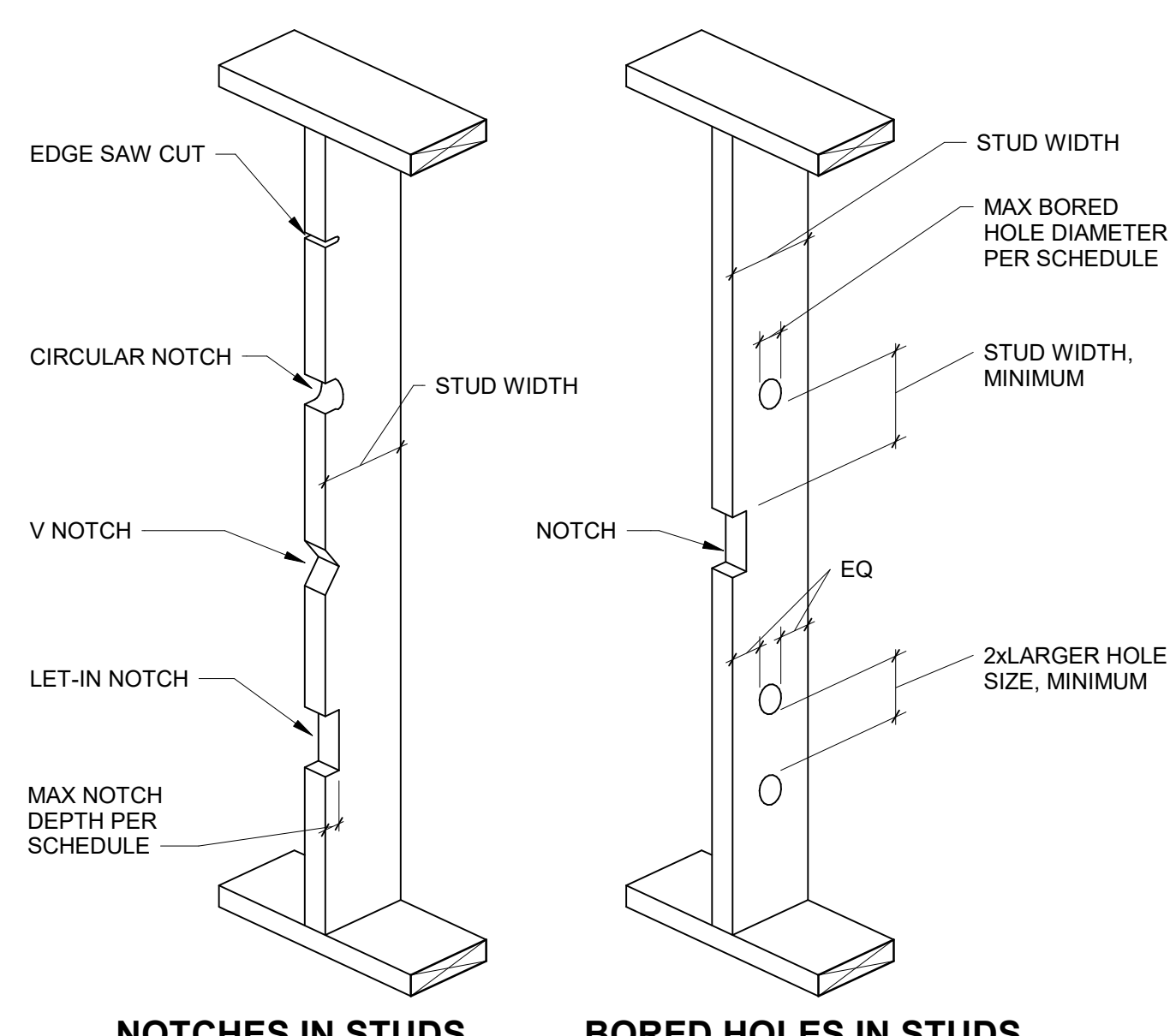

NOTCHES IN STUDS BORED HOLES IN STUDS

EXTERIOR/BEARING/SHEAR WALL STUD PENETRATION		
STUD SIZE	MAX NOTCH DEPTH	MAX BORED HOLE DIAMETER
2x4 & 3x4	7/8"	1-3/8"
2x6 & 3x6	1-3/8"	2-1/8"
2x8 & 3x8	1-3/4"	2-7/8"

NON-BEARING WALL STUD PENETRATION		
STUD SIZE	MAX NOTCH DEPTH	MAX BORED HOLE DIAMETER
2x4 & 3x4	1-3/8"	2"
2x6 & 3x6	2-1/8"	3-1/4"
2x8 & 3x8	2-7/8"	4-1/4"

- NOTES:**
- DO NOT NOTCH OR BORE HOLES IN MORE THAN TWO ADJACENT STUDS WITHOUT APPROVAL BY STRUCTURAL ENGINEER
 - NOTCHES AND BORED HOLES ARE NOT PERMITTED IN SHEAR WALL COMPRESSION STUDS.

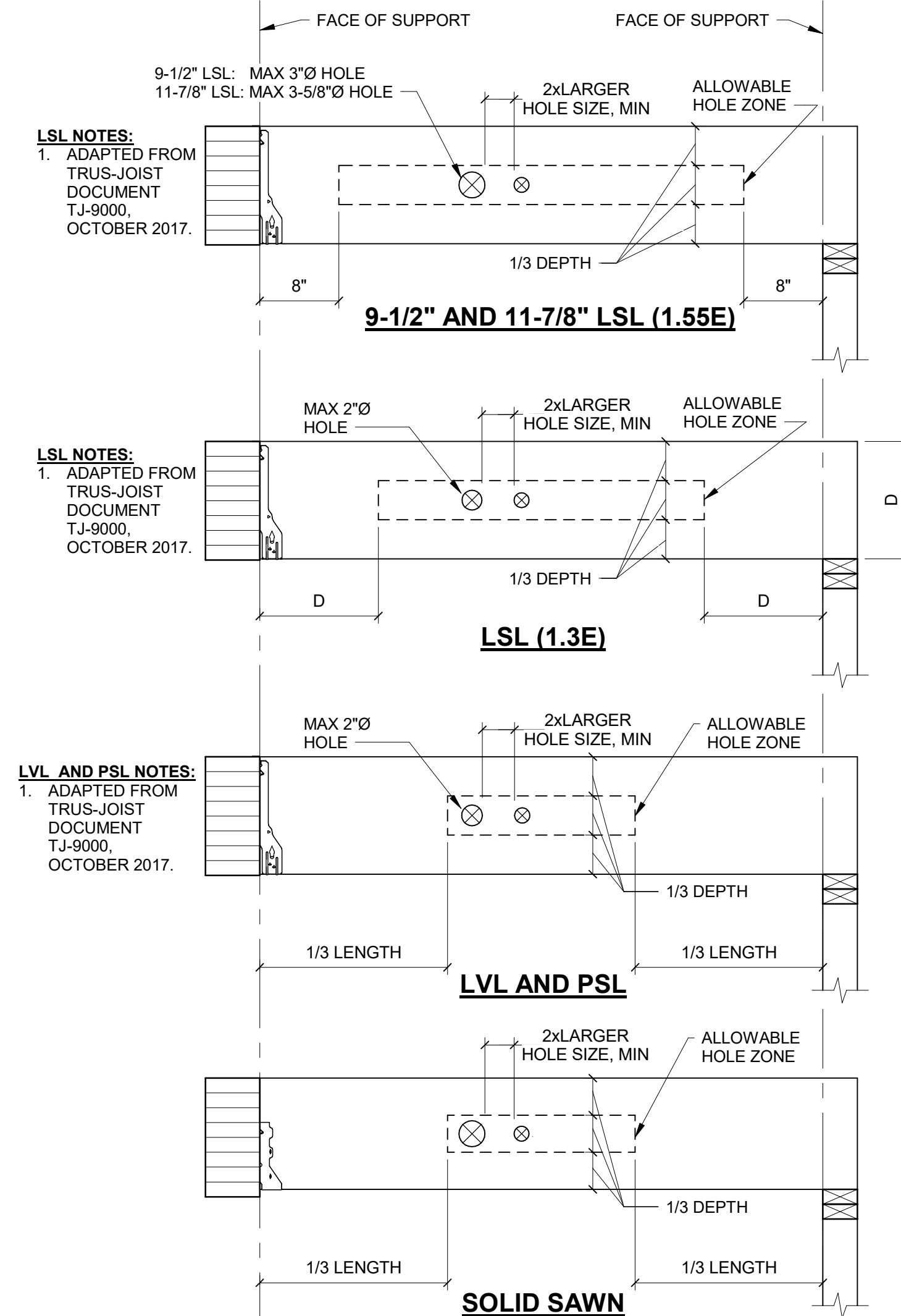

PARALLEL TO JOISTS PERPENDICULAR TO JOISTS

- NOTES:**
- DO NOT INSTALL NON-BEARING PARTITIONS UNTIL DEAD LOAD IS IN PLACE AT ROOF CONSTRUCTION AND WHERE A DEFLECTION SPACE HAS BEEN PROVIDED FOR, THIS REQUIREMENT MAY BE WAIVED
 - DO NOT CONNECT CEILING GYP BOARD TO FRAMING WITHIN 24" OF NON-STRUCTURAL PARTITION WALL. OPTION FOR CONTRACTOR TO USE SIMPSON DS DRYWALL STOP TO SUPPORT CEILING SHEATHING.

9 TYP INTERIOR NON-BEARING WALL TOP PLATE ANCHORAGE

NO SCALE

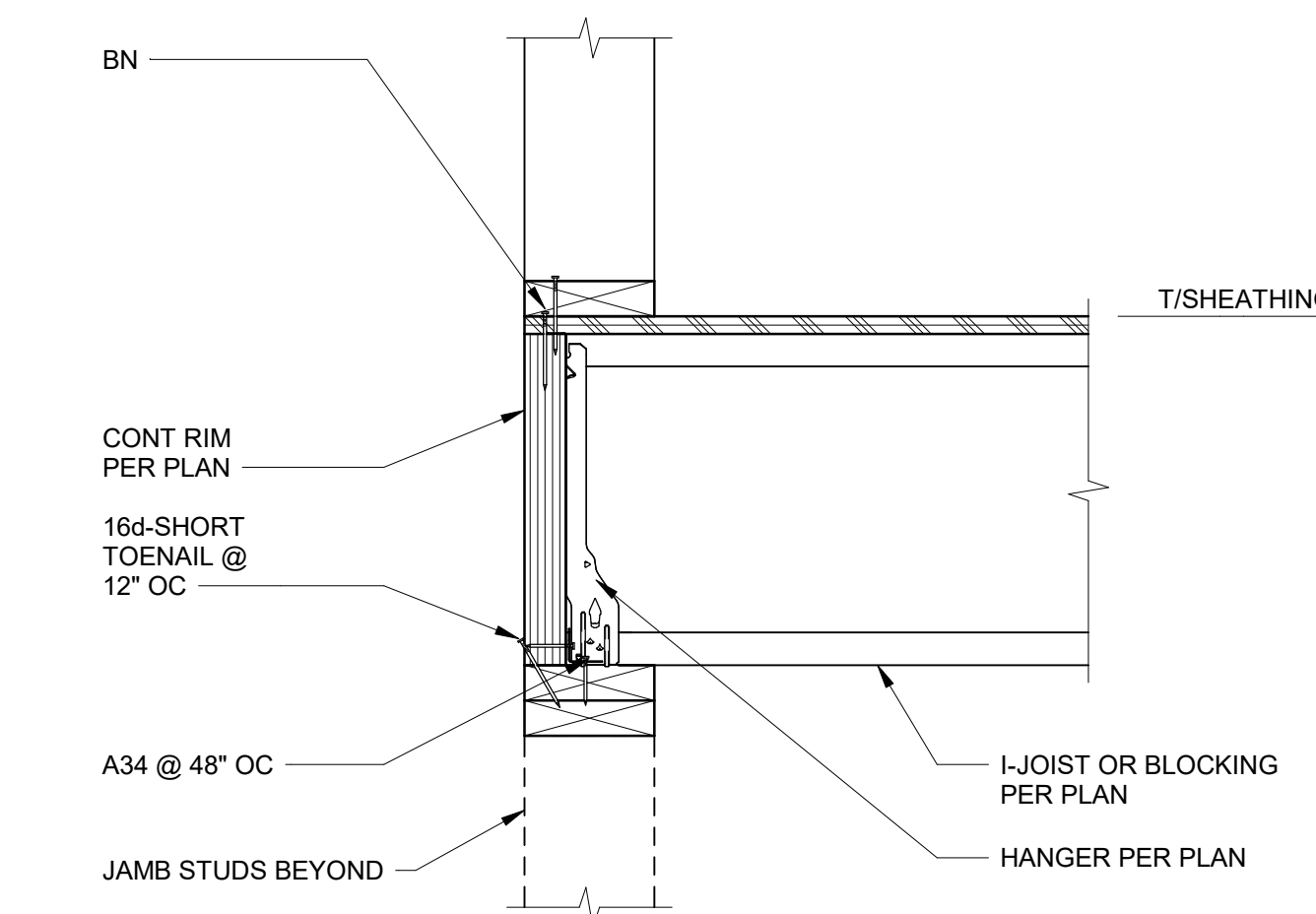

10 TYP RIM JOIST HEADER

NO SCALE

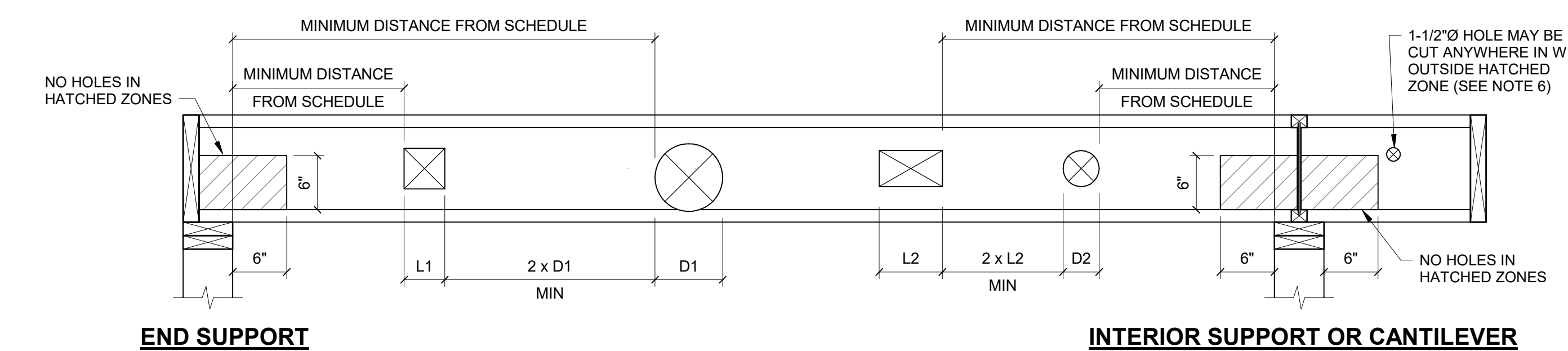

END SUPPORT

INTERIOR SUPPORT OR CANTILEVER

- NOTES:**
- ADAPTED FROM TRUS-JOIST DOCUMENT T3-4000, NOVEMBER 2017
 - HOLE SIZES: THE SIZES GIVEN IN THE TABLE ARE HOLE SIZES, NOT DUCT SIZES
 - MULTIPLE HOLES: WHERE MORE THAN ONE HOLE IS DESIRED, THE AMOUNT OF WOOD BETWEEN HOLES MUST BE EQUAL OR EXCEED TWICE THE DIAMETER OF THE LARGEST HOLE OR TWICE THE SIZE OF THE LARGEST SQUARE HOLE
 - HOLES MAY BE LOCATED VERTICALLY ANYWHERE WITHIN THE WEB. LEAVE 1/8" OF WEB MINIMUM AT TOP AND BOTTOM OF HOLE
 - ANY PENETRATIONS NOT MEETING THE REQUIREMENTS ABOVE MUST HAVE PRIOR APPROVAL BY THE STRUCTURAL ENGINEER
 - THIS TABLE IS BASED ON UNIFORMLY LOADED JOISTS. PENETRATIONS SHALL NOT BE PERMITTED AT JOISTS RECEIVING HEADERS OR SUPPORTING BEARING WALLS ABOVE WITHOUT PRIOR APPROVAL BY THE STRUCTURAL ENGINEER
 - DO NOT CUT HOLES LARGER THAN 1-1/2" IN CANTILEVERS

		MINIMUM DISTANCE FROM INSIDE FACE OF SUPPORT TO NEAREST EDGE OF HOLE								
JOIST TYPE	HOLE TYPE	AT END OF SUPPORT				AT INTERIOR SUPPORT OR CANTILEVER				
		2"	3"	4"	6 1/2"	2"	3"	4"	6 1/2"	
11-7/8" TJI 230	ROUND	1'-0"	1'-6"	2'-0"	3'-0"	6'-6"	1'-0"	2'-0"	5'-6"	10'-0"
11-7/8" TJI 230	RECTANGULAR	1'-0"	2'-0"	2'-6"	5'-6"	7'-0"	1'-0"	2'-6"	8'-6"	10'-6"

12 TYP WALL STUD PENETRATIONS

NO SCALE

13 TYP HOLES IN WOOD JOISTS AND BEAMS

NO SCALE

14 TYP HOLE CHART FOR I-JOISTS

NO SCALE

JOIST SCHEDULE	
TYPE MARK	TYPE AND SPACING
J-1	11-7/8" TJI 110 @ 16" OC
-	-
-	-

HEADER SCHEDULE		
WALL TYPE	HEADER SIZE	MAX ROUGH OPENING WIDTH
INTERIOR BEARING OR SHEAR WALL	(2) LSL 1-3/4x7-1/4	6'-6"
EXTERIOR WALL	LSL 3-1/2x11-7/8 RIM	8'-6"

BEAM SCHEDULE	
TYPE MARK	TYPE
B-1	LSL 3-1/2x11-7/8
-	-
-	-

- NOTES:**
- SEE 6/56.01 FOR WALL TYPE AND HEADER ELEVATION.

HANGER SCHEDULE			
MEMBER SIZE	FACE MOUNT	TOP FLANGE	TOP FLANGE SKEWED
11-7/8" TJI 110	IUS1.81/11.88	ITS1.81/11.88	LBV1.81/11.88
11-7/8" TJI 210	IUS2.06/11.88	ITS2.06/11.88	LBV2.06/11.88
11-7/8" TJI 230	IUS2.37/11.88	ITS2.37/11.88	LBV2.37/11.88
11-7/8" TJI 360	IUS2.37/11.88	ITS2.37/11.88	LBV2.37/11.88
11-7/8" TJI 560	IUS3.56/11.88	ITS3.56/11.88	LBV3.56/11.88
14" TJI 110	IUS1.81/14	ITS1.81/14 W/WEB STIFFENER	LBV1.81/14 W/WEB STIFFENER
2x6	LUS26	HJ26	HJ26TF
2x8	LUS26	HJ28	HJ28TF
LSL 1-3/4x11-7/8	HUS1.81/10	BA1.81/11.88 MAX NAILS	LBV1.81/11.88
LSL 3-1/2x11-7/8	HUS412	BA3.56/11.88 MAX NAILS	LBV3.56/11.88
PSL 3-1/2x11-7/8	HUS412	BA3.56/11.88 MAX NAILS	LBV3.56/11.88
PSL 5-1/4x11-7/8	HUS12	HBS.50/11.88	HWV3.50/11.88

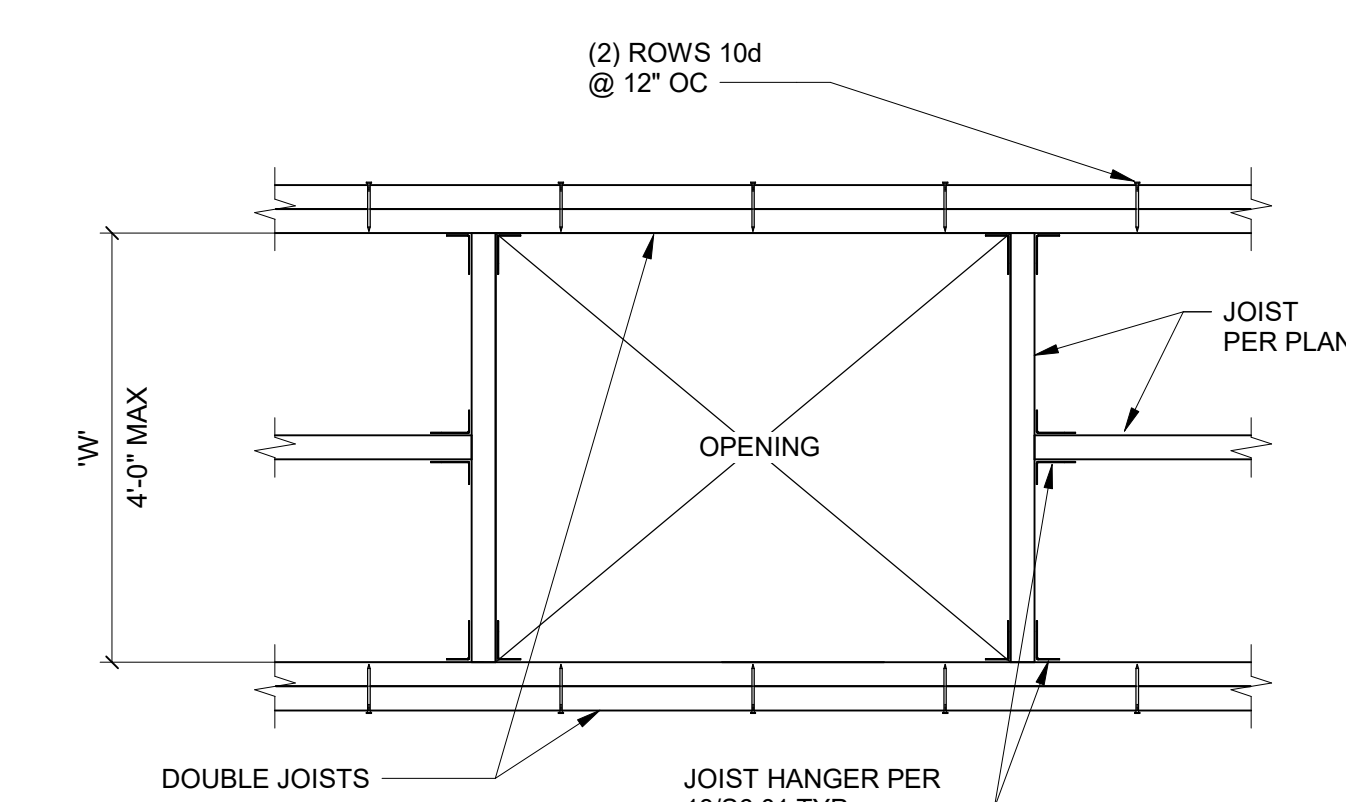

- NOTES:**
- WHEN OPENING DIMENSION 'W' EXCEEDS 4'-0", REFER TO PLANS FOR FRAMING.
 - WHEN I-JOISTS ARE USED, PROVIDE WEB BLOCKING BETWEEN DOUBLE JOISTS.

18 WOOD JOIST, HEADER, BEAM, AND HANGER SCHEDULES

NO SCALE

20 TYP FLOOR OPENING PLAN

NO SCALE



HARDWARE SCHEDULE		
TYPE MARK	SIMPSON MODEL #	TYPE COMMENTS
A	CS16	(20) 10" AND 11" END LENGTHS
B	-	-
C	-	-
D	-	-
E	-	-
F	-	-
G	-	-
H	-	-

HOLD-DOWN AND COMPRESSION STUD SCHEDULE					
TYPE MARK	HOLD-DOWN	THREADED ROD SIZE	WASHER PL SIZE	MIN ROD EMBEDMENT	COMPRESSION STUDS, SEE NOTE 1
1	DT12Z-SDS2.5	1/2"	1/2x2 1/2x0'-2 1/2"	-	(2) 2x6
2	HDU4-SDS2.5	5/8"	1/2x2 1/2x0'-2 1/2"	-	(2) 2x6
3	HDU8-SDS2.5	7/8"	1/2x3x0'-3"	-	(2) 2x6
4	HDU11-SDS2.5	1"	1/2x3x0'-3"	-	(2) 2x6
5	(2) HDU14-SDS2.5	1"	1/2x3x0'-3"	-	(3) 2x6
6	(2) HDU14-SDS2.5	1"	1/2x3x0'-3"	-	(4) 2x6

BUILT-UP COLUMN SCHEDULE	
TYPE MARK	STUD SIZE AND QUANTITY
1	(2) 2x6
2	(3) 2x6
3	(4) 2x6

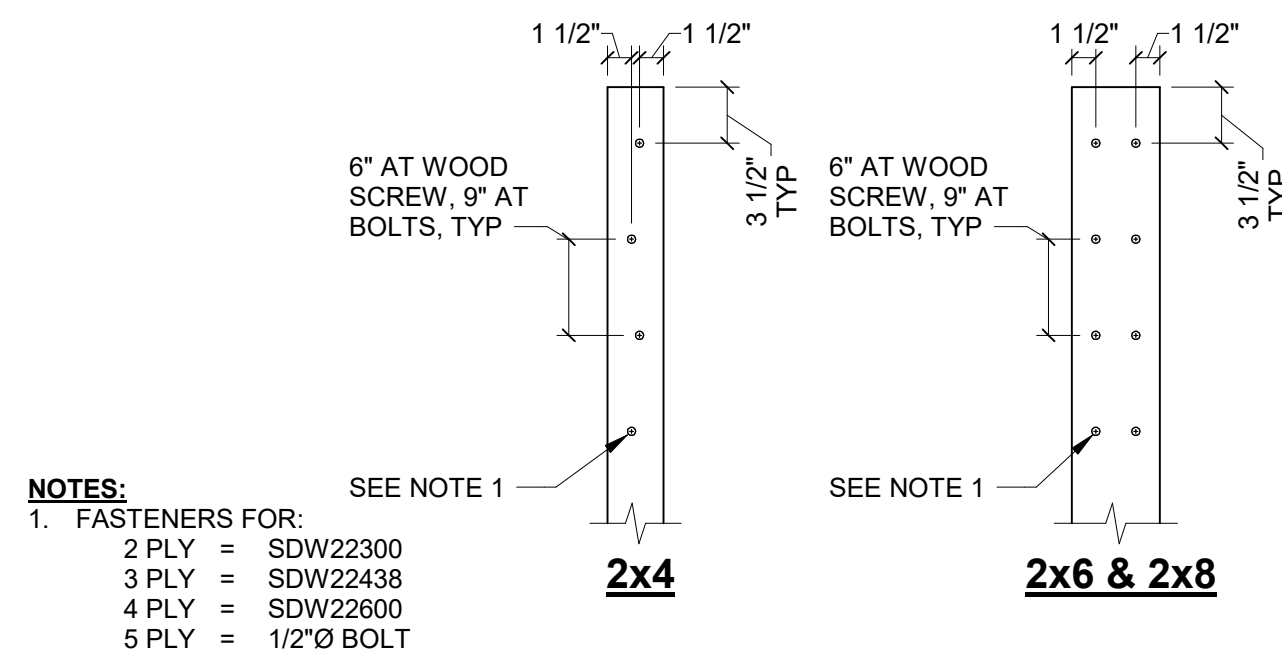

NOTES:
 1. FASTEN COMPRESSION STUDS TOGETHER PER 3/96.02.

1. **HARDWARE SCHEDULE**
NO SCALE

2. **HOLD-DOWN AND COMPRESSION STUD SCHEDULE**
NO SCALE

3. **BUILT-UP COLUMN SCHEDULE**
NO SCALE

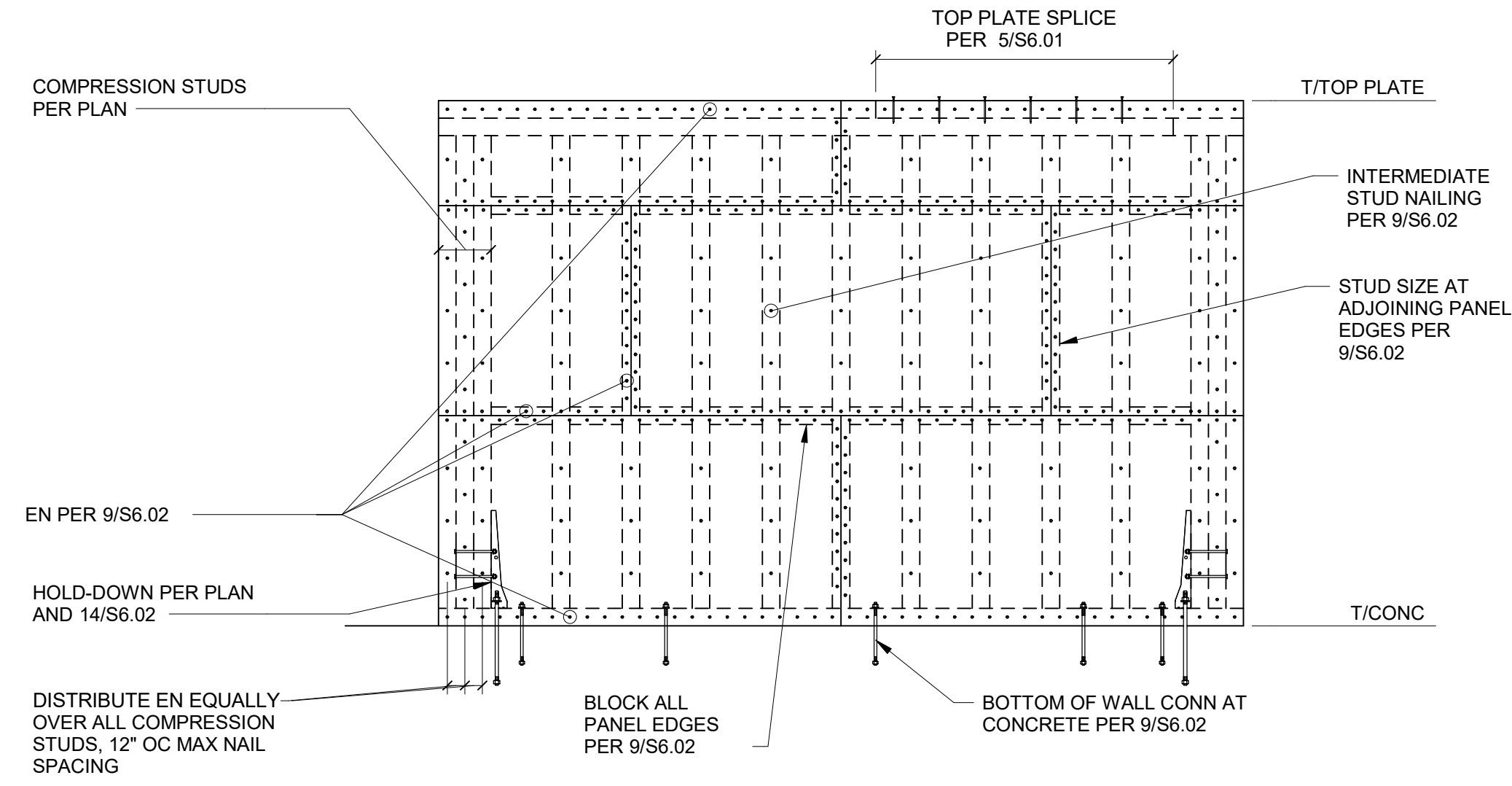
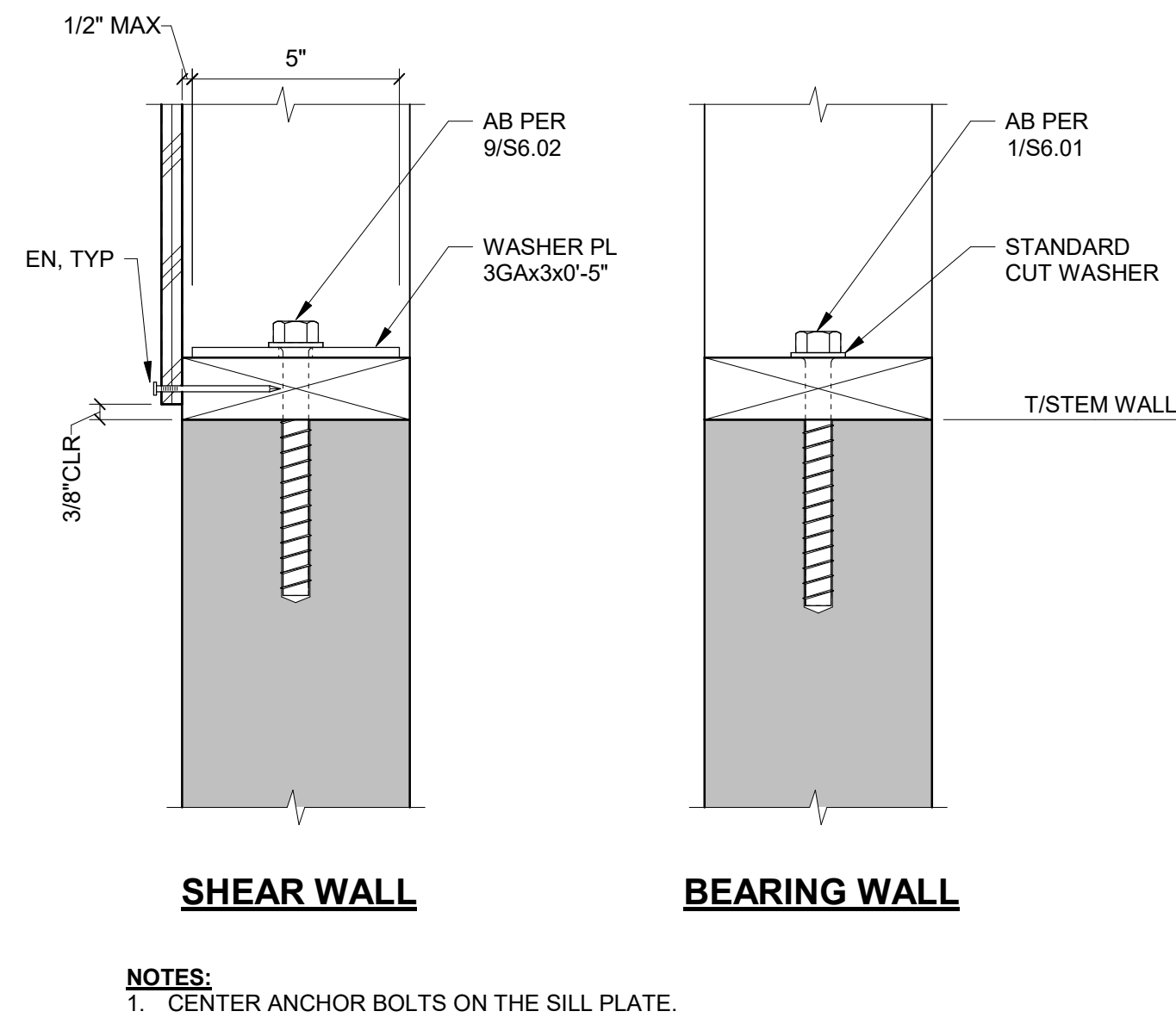

6. **TYP ANCHOR BOLTS AT STEM WALL**
NO SCALE

7. **TYP SHEAR WALL NAILING**
NO SCALE

9. **WOOD SHEAR WALL SCHEDULE**
NO SCALE

WOOD SHEAR WALL SCHEDULE									
ALL VALUES ARE BASED ON 2018 IBC AND SDPWS-15 FOR STRUCTURAL PANEL SHEAR WALL WITH FRAMING OF DOUGLAS FIR-LARCH									
TYPE MARK	NUMBER OF SIDES OF SHEATHING	STUD OR BLOCKING SIZE AT ADJOINING PANEL EDGES, SEE NOTE 11	FASTENER SPACING		BOTTOM OF WALL CONNECTION		TOP OF WALL CONNECTION	SEISMIC ALLOWABLE SHEAR (LBS/FT)	
			WALL BOUNDARIES AND PANEL EDGES, SEE NOTE 9	INTERMEDIATE STUDS, SEE NOTE 10	FIELD OF SLAB, SEE NOTE 8	NEAR EDGE, SEE NOTE 8			AT WOOD FLOOR
SW-6	1	2x	6" OC	12" OC	5/8" AB @ 48" OC	5/8" AB @ 24" OC	SDS25600 @ 16" OC	SDS25600 @ 16" OC	310
SW-4	1	3x	4" OC	12" OC	5/8" AB @ 48" OC	5/8" AB @ 16" OC	SDS25600 @ 12" OC	SDS25600 @ 12" OC	460
SW-3	1	3x	3" OC	12" OC	5/8" AB @ 32" OC	5/8" AB @ 12" OC	SDS25600 @ 8" OC	SDS25600 @ 8" OC	600
SW-2	1	3x	2" OC	12" OC	5/8" AB @ 24" OC	5/8" AB @ 8" OC	SDS25600 @ 8" OC	SDS25600 @ 8" OC	770
2SW-4	2	3x	4" OC	12" OC	5/8" AB @ 24" OC	5/8" AB @ 8" OC	SDS25600 @ 8" OC	SDS25600 @ 6" OC	920
2SW-3	2	3x	3" OC	12" OC	5/8" AB @ 16" OC	-	SDS25600 @ 4" OC	SDS25600 @ 4" OC	1,200

NOTES:
 1. SHEATHING NAIL SIZE SHALL BE 0.148" WITH 1-1/2" MINIMUM PENETRATION INTO FRAMING.
 2. REFERENCE STRUCTURAL NOTES FOR SHEATHING TYPE AND THICKNESS.
 3. INSTALL SHEATHING PANELS EITHER HORIZONTALLY OR VERTICALLY.
 4. PLATE WASHERS FOR SILL BOLTS SHALL BE PER 0/56.02
 5. WHERE NAIL SPACING IS LESS THAN 4" OC, STAGGER EDGE NAILING 1/2".
 6. REFER TO 7/58.02 FOR SHEAR WALL NAILING DETAIL.
 7. PRESSURE TREATED SILL PLATE SHALL BE 3x FRAMING.
 8. USE NEAR EDGE SPACING WHEN ANCHOR BOLTS ARE WITHIN 12" OF A SLAB EDGE OR SHAFT OPENING, OR ARE PLACED IN A STEM WALL.
 9. WALL BOUNDARIES INCLUDE TOP PLATE, BOTTOM PLATE, SILL PLATE, AND COMPRESSION STUDS, UNO.
 10. FASTENER SPACING AT INTERMEDIATE MEMBERS SHALL BE 6" OC WHERE STUD SPACING IS 24" OC.
 11. AT CONTRACTOR'S OPTION, (2) 2x STUDS MAY BE USED IN LIEU OF 3x STUD FRAMING. SEE 2/356.02 FOR DOUBLE STUD FASTENING.
 12. WHERE SHEATHING IS APPLIED ON BOTH SIDES OF WALL, PANEL EDGE JOINTS SHALL BE STAGGERED SO THAT JOINTS ON THE OPPOSITE SIDES ARE NOT LOCATED ON THE SAME STUD.

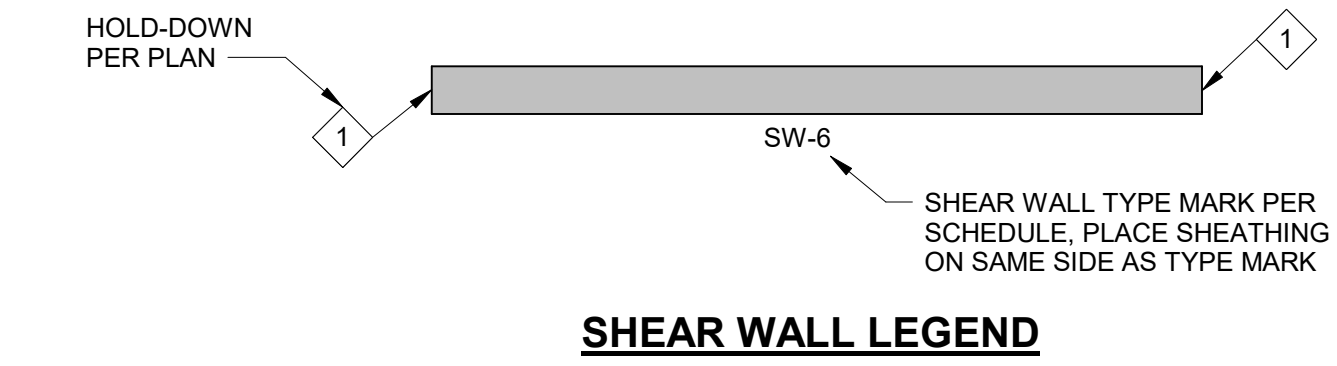

ROOF/FLOOR DIAPHRAGM NAILING SCHEDULE									
ALL VALUES ARE BASED ON 2018 IBC AND SDPWS-15 FOR STRUCTURAL PANEL DIAPHRAGMS WITH FRAMING OF DOUGLAS FIR-LARCH									
LOCATION	SHEATHING CATEGORY	BLOCKING REQUIRED	MIN FRAMING AND BLKG WIDTH	NUMBER OF LINES OF FASTENERS	FASTENER SPACING			SEISMIC ALLOWABLE SHEAR (LBS/FT)	
					DIAPHRAGM BOUNDARIES, SEE NOTE 3	CONTINUOUS PANEL EDGES	OTHER PANEL EDGES		INTERMEDIATE FRAMING MEMBERS
FLOOR	23/32	NO	2x	1	6" OC	-	6" OC	12" OC	215
ROOF	19/32	YES	2x	1	4" OC	4" OC	6" OC	12" OC	480

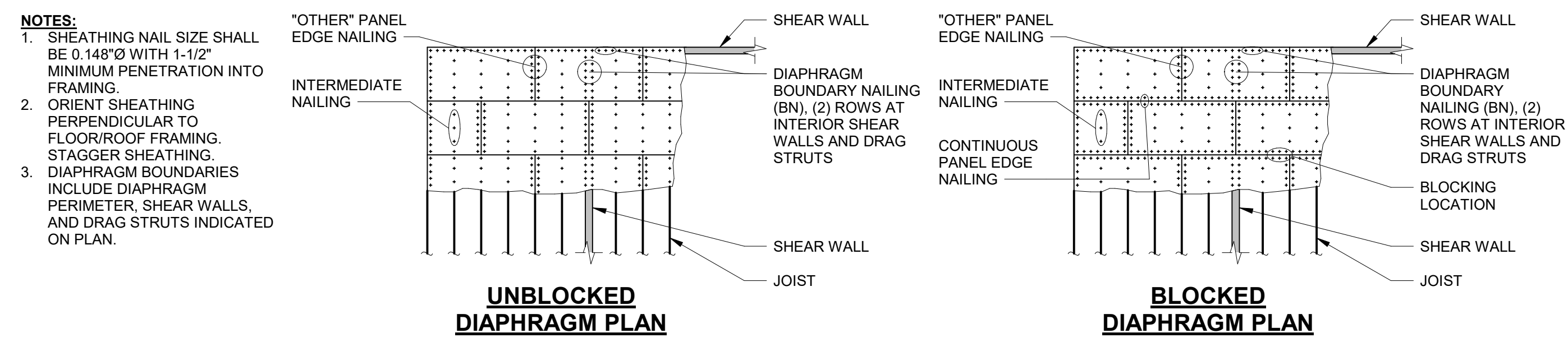

11. **ROOF/FLOOR DIAPHRAGM NAILING SCHEDULE**
NO SCALE

13. **TYP HOLD-DOWN AT FLOOR**
NO SCALE

14. **TYP HOLD-DOWN AT FOUNDATION**
NO SCALE

15. **STRAPS AROUND SHEAR WALL OPENINGS**
NO SCALE

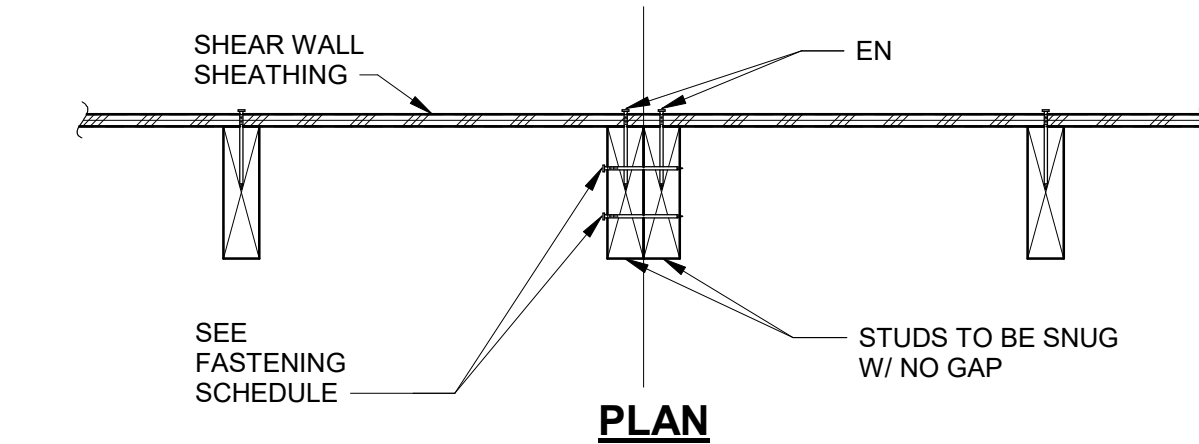
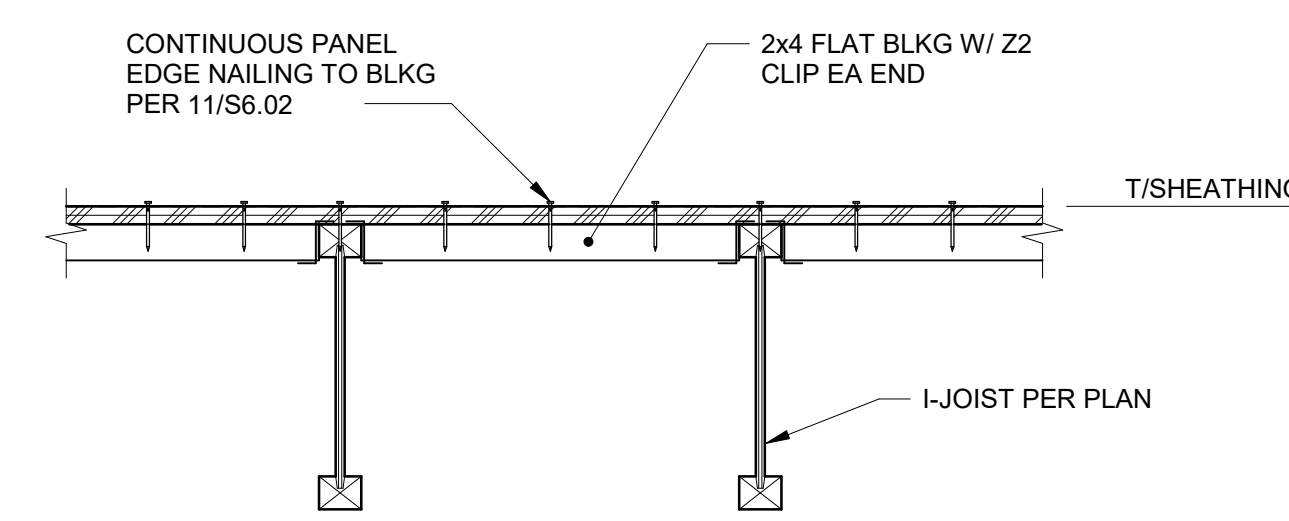
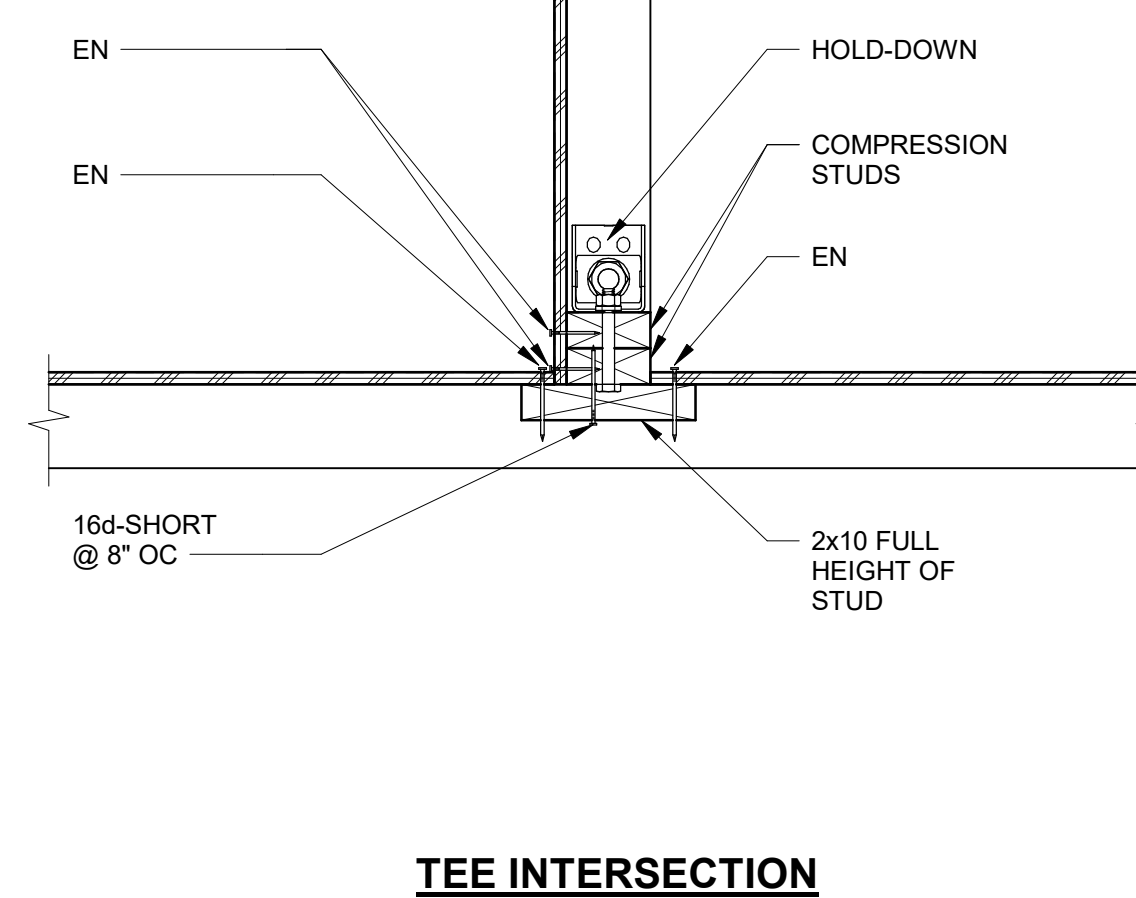
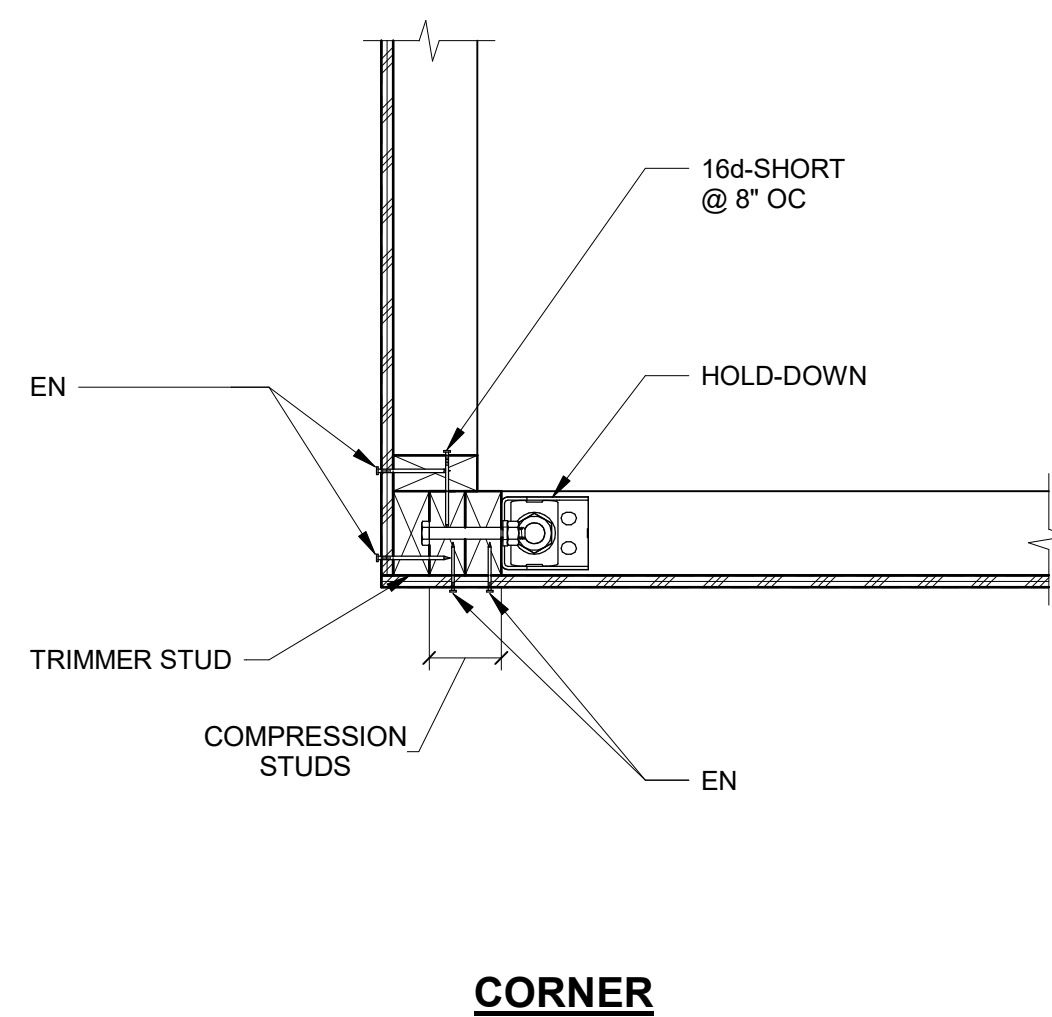

STUD FASTENING SCHEDULE AT PANEL JOINTS	
SHEAR WALL TYPE	STUD FASTENING
SW6	(2) 16d-SHORT @ 12" OC
SW4	(2) 16d-SHORT @ 8" OC
SW3	(2) 16d-SHORT @ 6" OC
SW2	(2) 16d-SHORT @ 4" OC
2SW4	(2) 16d-SHORT @ 4" OC
2SW3	(2) 16d-SHORT @ 3" OC

NOTES:
 1. THIS DETAIL APPLIES WHERE DOUBLE 2x STUDS ARE USED AT SHEAR WALL PANEL JOINTS IN LIEU OF 3x FRAMING PER NOTE 11 ON 0/56.02.
 2. WHERE NAIL SPACING IS LESS THAN 4" OC, STAGGER NAILING 1/2" IN EACH ROW.

19. **TYP DIAPHRAGM BLOCKING AT PANEL EDGES**
NO SCALE

20. **STUD FASTENING AT SHEAR WALL PANEL JNTS**
NO SCALE

17. **TYP COMPRESSION STUD INTERSECTION**
NO SCALE

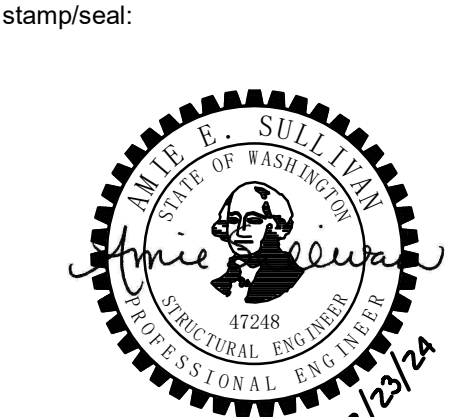

stamp: kpf



1601 Fifth Avenue, Suite 1600
 Seattle, WA 98101
 206.422.5822
 kpf.com

project engineer: CRL
 project manager: JRS
 drawn by: BMF
 checked by: AES
 job no.: 220638

revisions:

no. date description:

PERMIT
 09/08/2023

sheet: **S6.02**

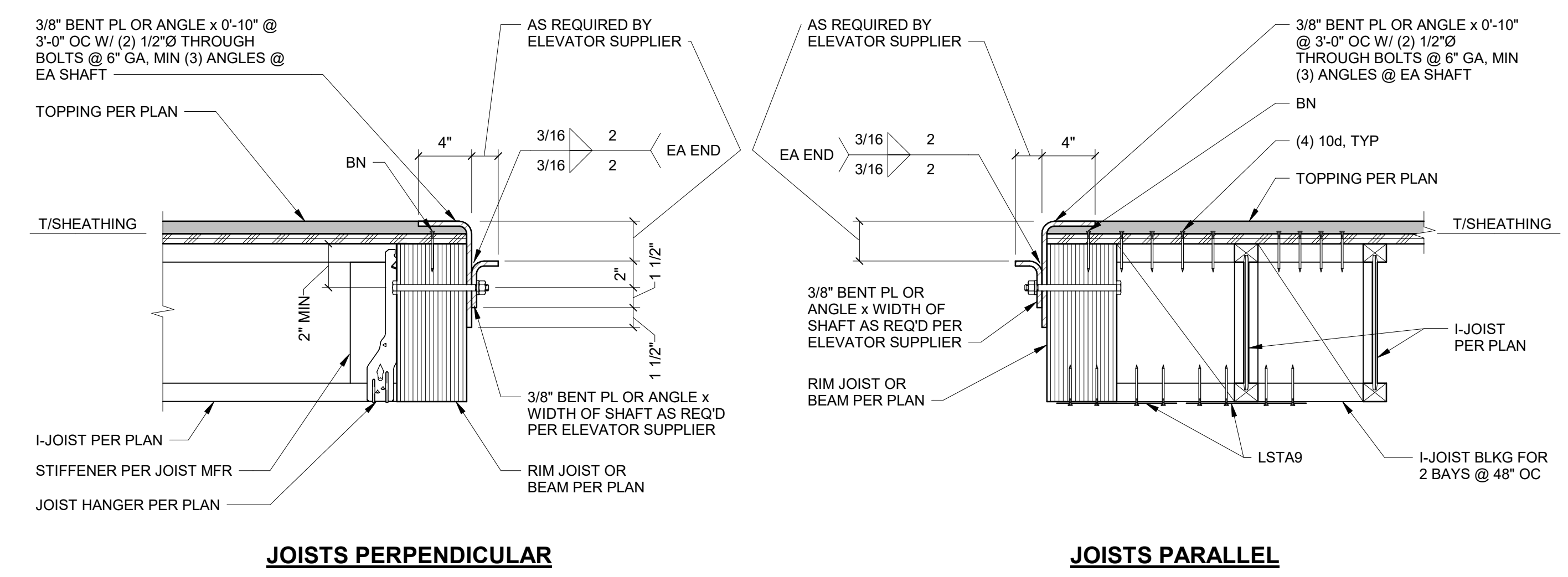

4 TYP ELEVATOR DOOR SILL
NO SCALE

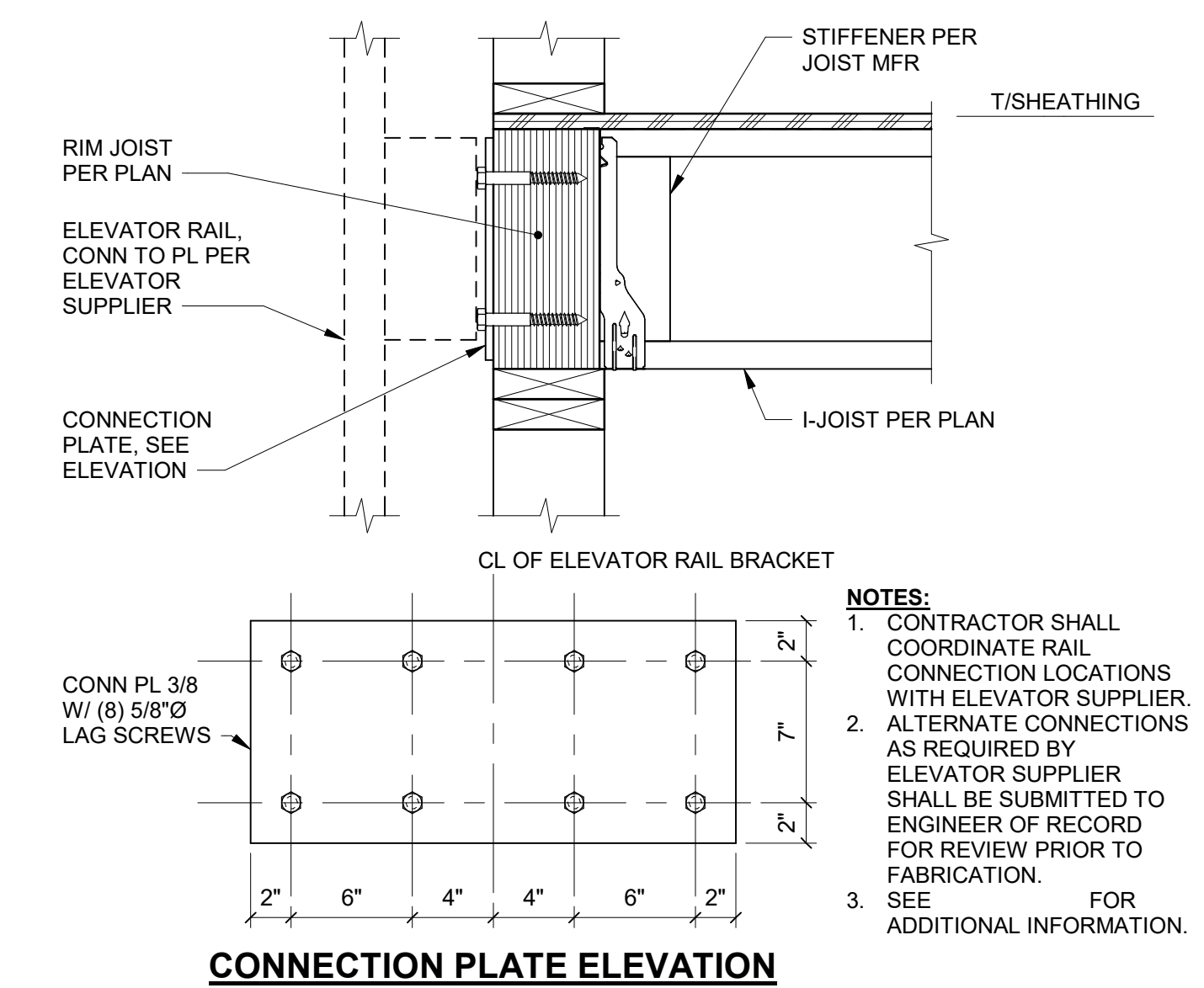

9 TYP ELEVATOR RAIL CONNECTION PLATE
NO SCALE

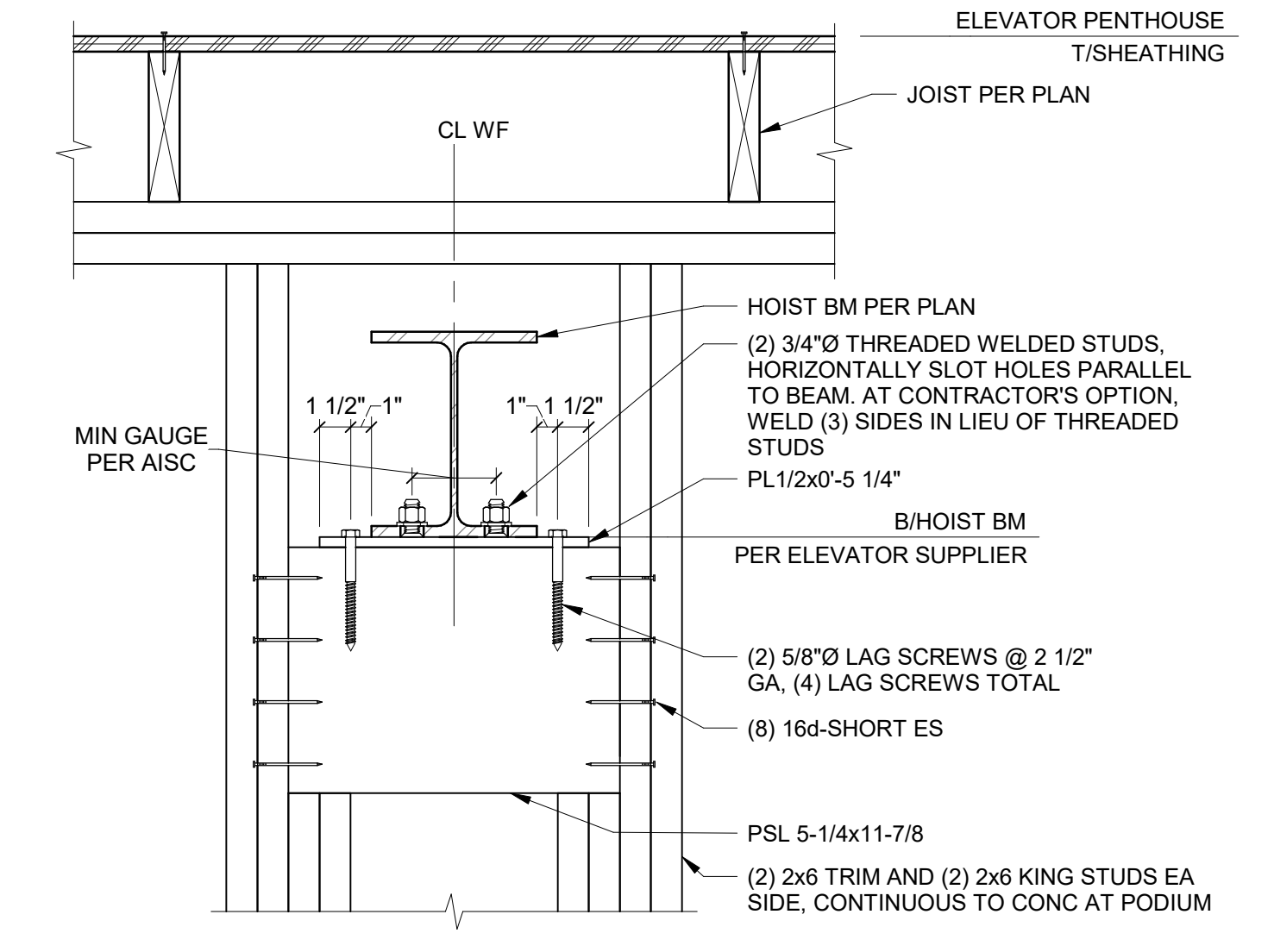

10 TYP ELEVATOR HOIST BEAM CONNECTION
NO SCALE

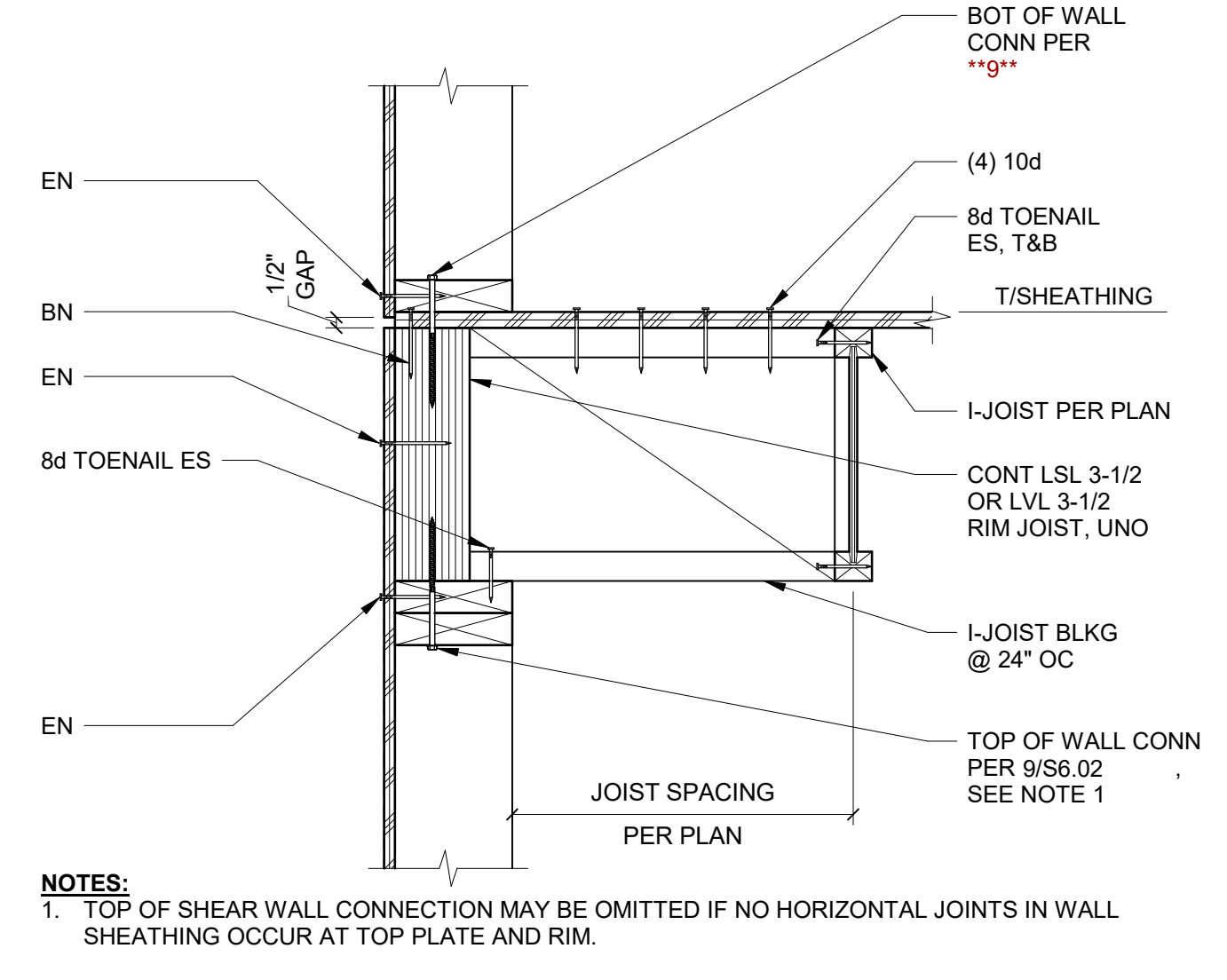

13 TYP EXTERIOR SHEAR WALL - FRAMING PARALLEL (1-SIDED)
NO SCALE

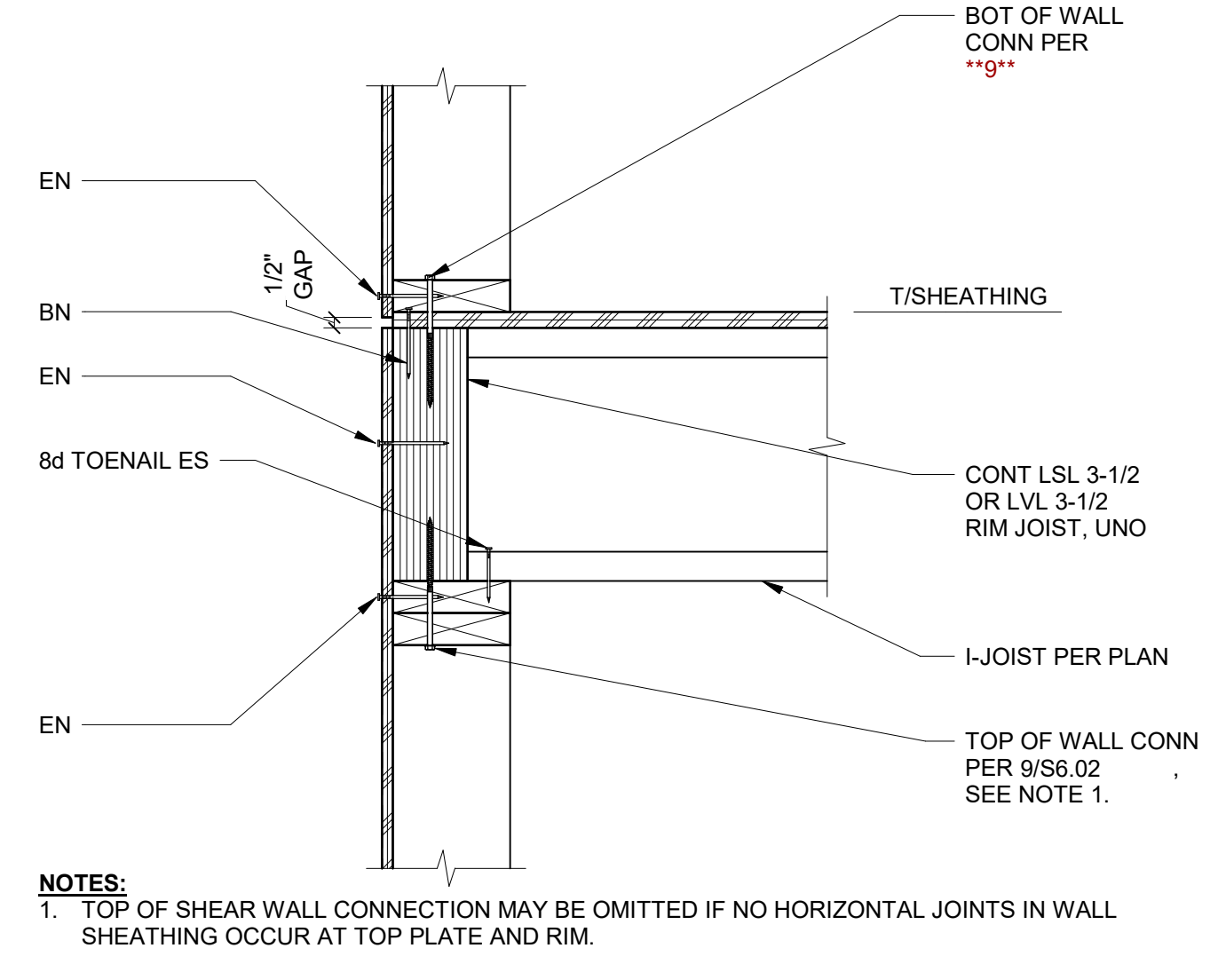

14 TYP EXTERIOR SHEAR WALL - FRAMING PERPENDICULAR (1-SIDED)
NO SCALE

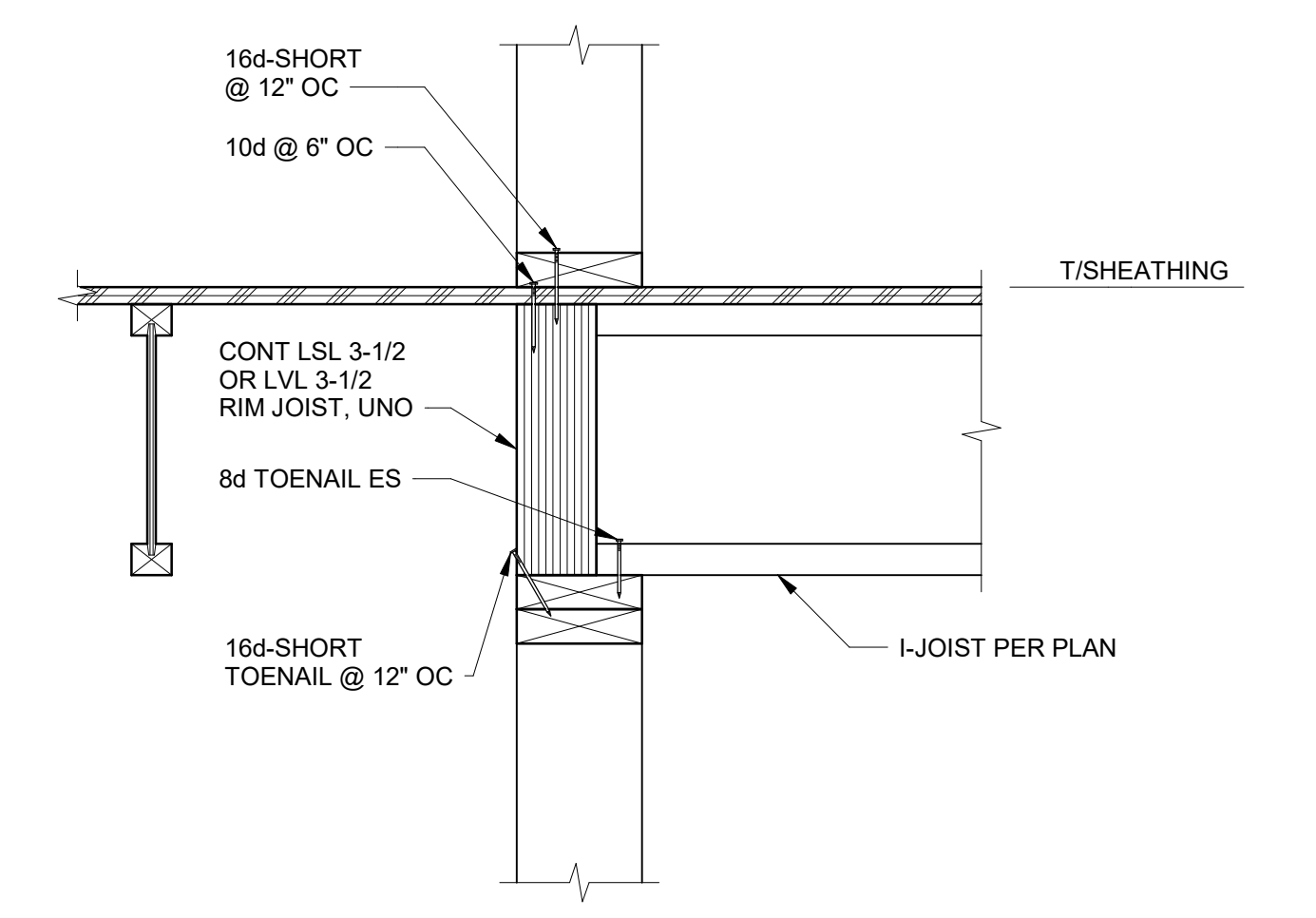

15 TYP INTERIOR BEARING WALL - FRAMING DIRECTION CHANGE
NO SCALE

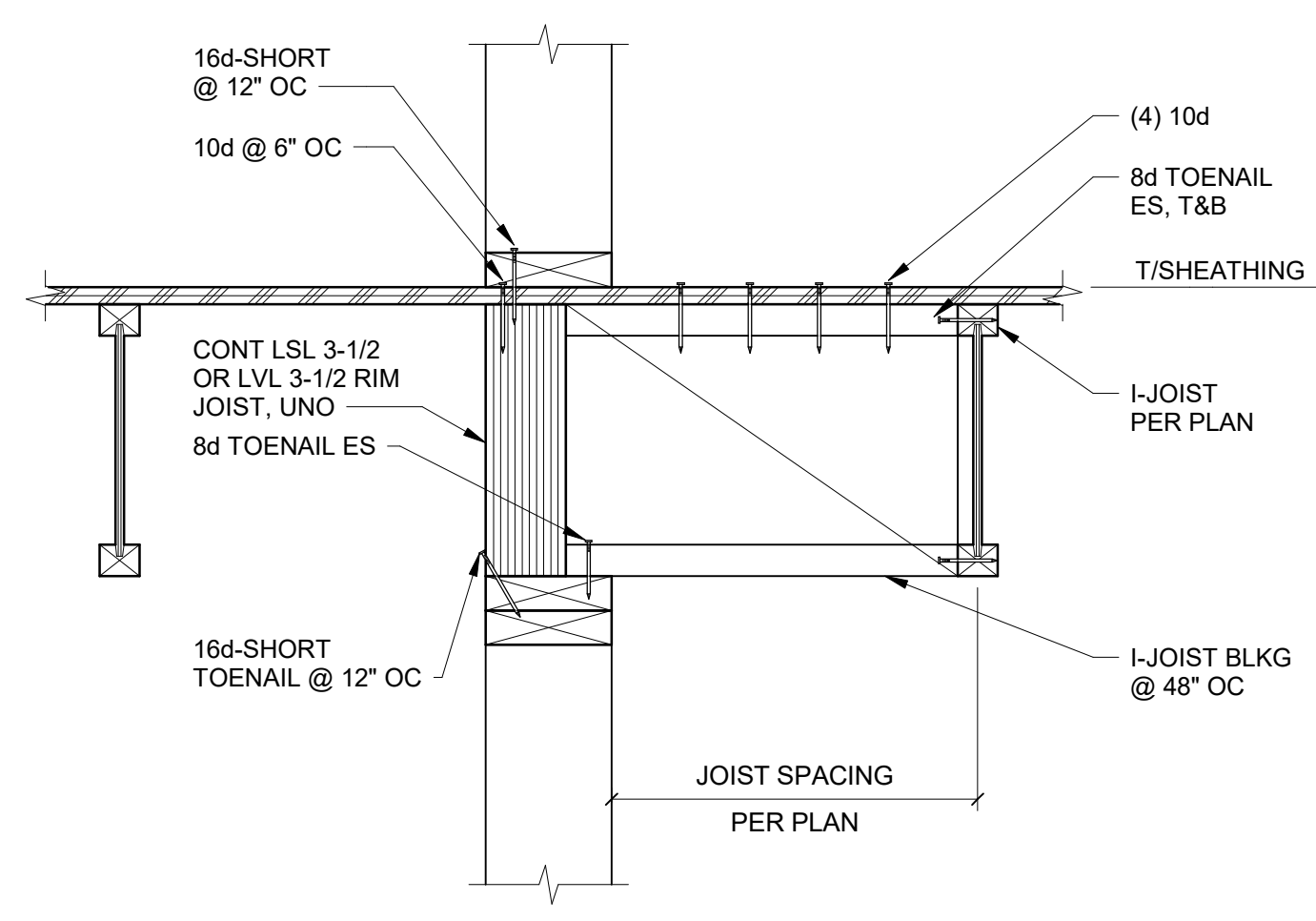

19 TYP INTERIOR BEARING WALL - FRAMING PARALLEL
NO SCALE

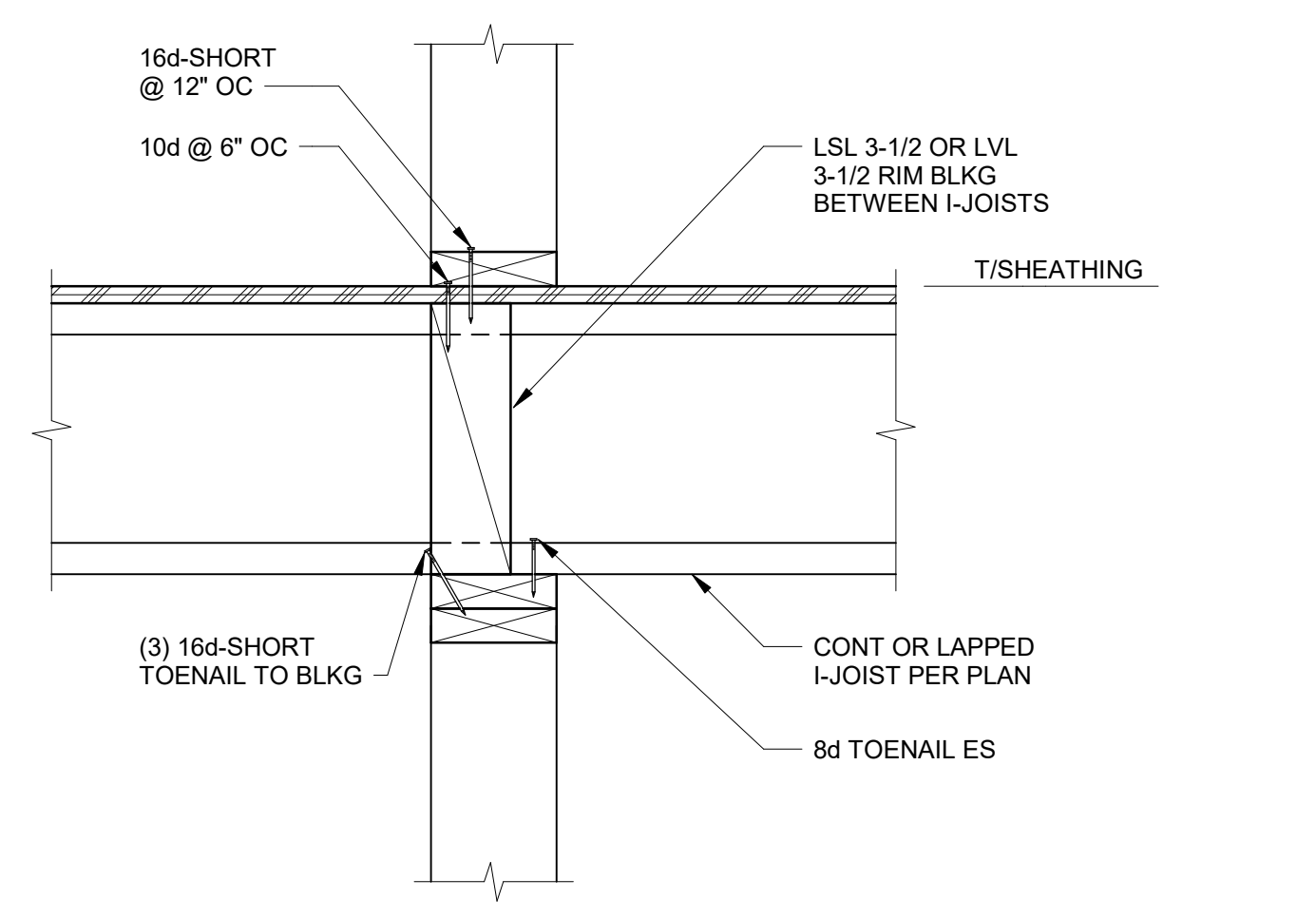

20 TYP INTERIOR BEARING WALL - FRAMING PERPENDICULAR
NO SCALE

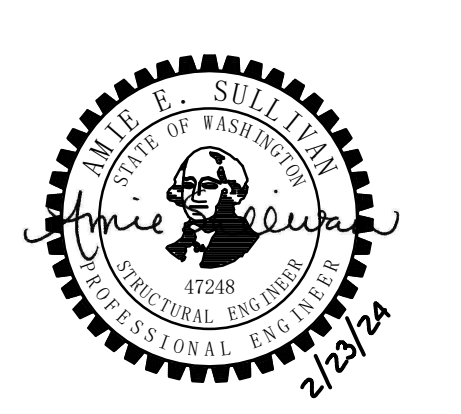

stamp/seal



1601 Fifth Avenue, Suite 1600
Seattle, WA 98101
206.622.5822
kpff.com

project engineer	CSL
project manager	JRS
drawn by	BMF
checked by	AES
job no.	2200638

PERMIT
09/08/2023

SHORING NOTES

GENERAL SHORING NOTES

ALL DESIGN AND CONSTRUCTION SHALL CONFORM TO THE REQUIREMENTS OF THE INTERNATIONAL BUILDING CODE (IBC), 2018 EDITION, AS AMENDED BY THE CITY OF MERCER ISLAND.

- RECOMMENDATIONS FOR PRESTRESSED ROCK AND SOIL ANCHORS" BY THE POST-TENSIONING INSTITUTE, LATEST EDITION.
- GEO-TECHNICAL REPORT BY ASSOCIATED EARTH SCIENCES, INC., DATED AUGUST 16, 2022.

DESIGN LOADS THE SOIL PRESSURES RECOMMENDED IN THE GEO-TECHNICAL REPORT WERE USED FOR DESIGN.

SUBMITTALS SHOP DRAWINGS SHALL BE SUBMITTED TO THE ARCHITECT AND ENGINEER PRIOR TO ANY FABRICATION OR CONSTRUCTION FOR ALL STRUCTURAL ITEMS.

INSPECTION SPECIAL INSPECTION PER IBC CHAPTER 17 BY A QUALIFIED GEO-TECHNICAL ENGINEER OR INDEPENDENT TESTING LAB WILL BE PROVIDED BY THE OWNER AS INDICATED IN THE STATEMENT OF SPECIAL INSPECTIONS AND TESTING FOR EXCAVATION SHORING.

SPECIAL CONDITIONS CONTRACTOR SHALL VERIFY ALL LEVELS, DIMENSIONS, AND EXISTING CONDITIONS IN THE FIELD BEFORE PROCEEDING. CONTRACTOR SHALL NOTIFY THE ENGINEER OF ANY DISCREPANCIES OR FIELD CHANGES PRIOR TO INSTALLATION OR FABRICATION. IN CASE OF DISCREPANCIES BETWEEN THE EXISTING CONDITIONS AND THE DRAWINGS, THE CONTRACTOR SHALL OBTAIN DIRECTION FROM THE ENGINEER BEFORE PROCEEDING. DIMENSIONS NOTED AS PLUS OR MINUS (+) INDICATE UNVERIFIED DIMENSIONS AND ARE APPROXIMATE. NOTIFY ENGINEER IMMEDIATELY OF CONFLICTS OR EXCESSIVE VARIATIONS FROM INDICATED DIMENSIONS. NOTED DIMENSIONS TAKE PRECEDENCE OVER SCALED DIMENSIONS--DO NOT SCALE DRAWINGS.

UTILITY LOCATION UTILIZE THE SERVICES OF THE "UTILITY LOCATOR SERVICE" (1-800-424-5555) TO VERIFY THE EXTENT AND LOCATIONS AND ALIGNMENTS OF SITE UTILITIES. IF THE ACTUAL FIELD VERIFIED LOCATIONS OF UTILITIES COULD RESULT IN A CONFLICT WITH THE SHORING, NOTIFY THE ENGINEER IMMEDIATELY. DO NOT DAMAGE EXISTING UTILITIES.

PRIOR TO CONSTRUCTION, VERIFY THAT OVER-HEAD OBSTRUCTIONS, INCLUDING ELECTRICAL LINES, DO NOT INTERFERE WITH THE CONTRACTORS DRILLING EQUIPMENT.

CONCRETE CONCRETE WORK SHALL CONFORM TO ALL REQUIREMENTS OF IBC CHAPTER 19. CONCRETE MIXTURES SHALL CONFORM TO THE FOLLOWING REQUIREMENTS:

	MINIMUM CEMENT PER CUBIC YARD	USE
4 SACKS	1	STRUCTURAL CONCRETE
1 1/2 SACKS	1	LEAN MIX

CONCRETE STRENGTH TEST AGE SHALL BE 28 DAYS, UNLESS NOTED OTHERWISE.

ADMITTURS SHALL CONFORM TO ASTM C 494. DO NOT USE ADMITTURS THAT WEAKEN THE CONCRETE MIX.

WATER-REDUCING ADMIXTURES MAY BE INCORPORATED IN CONCRETE MIX DESIGNS, BUT SHALL CONFORM TO ASTM C 494, AND BE USED IN COMPLIANCE WITH THE MANUFACTURER'S RECOMMENDATIONS. CA2C OR OTHER WATER-SOLUBLE CHLORIDE ADMIXTURES SHALL NOT BE USED.

SUBMIT CONCRETE MIX DESIGNS TO THE ENGINEER FOR APPROVAL TWO WEEKS PRIOR TO PLACING ANY CONCRETE. THE MIX DESIGN SHALL BE IN CONFORMANCE WITH ACI 318, CHAPTER 19.

CONTROLLED DENSITY FILL CDF SHALL BE PER SECTION 2-09.31(E "BACKFILLING") OF THE 2016 EDITION WASHINGTON STATE DEPARTMENT OF TRANSPORTATION STANDARD SPECIFICATIONS FOR ROAD, BRIDGE AND MUNICIPAL CONSTRUCTION.

TIEBACK GROUT NEAT CEMENT OR SAND/CEMENT MIXTURE WITH A MINIMUM 3-DAY COMPRESSIVE STRENGTH OF 1,500 PSI AND A MINIMUM 28-DAY COMPRESSIVE STRENGTH OF 3,000 PSI, PER ASTM C 195.

PRESTRESSING STEEL UNCOATED SEVEN WIRE STRESS RELIEVED STRAND GRADE 270 SHALL CONFORM TO ASTM A 416.

STEEL REFERENCE SPECIFICATIONS DESIGN, FABRICATION AND ERECTION SHALL BE IN ACCORDANCE WITH THE FOLLOWING SPECIFICATIONS:

STRUCTURAL STEEL	AISC SPECIFICATION FOR STRUCTURAL STEEL BUILDINGS, LATEST EDITION
WELDING	AWS D1.1 AWS PREQUALIFIED JOINT DETAILS
WELDER CERTIFICATION	AMERICAN WELDING SOCIETY (AWS) WASHINGTON ASSOCIATION OF BUILDING OFFICIALS (WAAB)

STEEL MATERIALS

WELD FLANGE SHAPES (W AND WT)	ASTM A 992
ANGLES (L), BARS	ASTM A 36 TYPICAL
FLATES (PL), BARS	ASTM A 572 GRADE 50 WHERE NOTED
STRUCTURAL TUBES (STS)	ASTM A 36
STRUCTURAL TUBES (CS)	ASTM A 500, GRADE C
STEEL PIPE	ASTM A 53, GRADE B
STEEL PIPE 12" AND LARGER	ASTM A 252, GRADE 3
STRUCTURAL BOLTS	ASTM F 3125, GRADE A 325
THREADED RODS	ASTM A 36, UNLESS NOTED OTHERWISE
WELDING ELECTRODES	70 KSL LOW HYDROGEN, TYPICAL

THE CONTRACTOR SHALL BE RESPONSIBLE FOR ALL ERECTION AIDS AND JOINT PREPARATIONS THAT INCLUDE, BUT ARE NOT LIMITED TO, ERECTION ANCHORS, LIFT HOLES AND OTHER AIDS, WELDING PREPARED ROOF OPENINGS, ROOT FACE DIMENSIONS, GROOVE ANGLES, BACKING BARS, COPES, SURFACE ROUGHNESS VALUES, AND UNEQUAL PARTS.

WELDED HEADED STUDS ALL STUDS SHALL BE AUTOMATICALLY END WELDED IN SHOP OR FIELD WITH EQUIPMENT RECOMMENDED BY MANUFACTURER WITH LENGTH AFTER WELD AS SHOWN ON THE STRUCTURAL DRAWINGS. WELDED HEADED STUDS ARE 3/4" UNLESS NOTED OTHERWISE AND SHALL CONFORM TO AWS D1.1 TYPE B.

WELDING ALL WELDING SHALL BE IN CONFORMANCE WITH AISC AND AWS STANDARDS, AND SHALL BE PERFORMED BY WABO-CERTIFIED WELDERS. ONLY WELDS THAT ARE PREQUALIFIED, AS DEFINED BY AWS, OR QUALIFIED BY TESTING SHALL BE USED. SHOP DRAWINGS SHALL SHOW ALL WELDING WITH AWS A2.4 SYMBOLS. WELDS SHOWN ON THE DRAWINGS ARE MINIMUM SIZES. INCREASE WELD SIZE TO AWS MINIMUM SIZES BASED ON THICKNESS. MINIMUM WELD SIZE SHALL BE 3/16" INCH, UNLESS NOTED OTHERWISE. THE WELDS SHOWN ARE FOR THE FINAL CONNECTIONS. FIELD WELD SYMBOLS ARE SHOWN WHERE FIELD WELDS ARE REQUIRED BY THE STRUCTURAL DESIGN, WHERE FIELD WELD IS NOT INDICATED, THE CONTRACTOR IS RESPONSIBLE FOR DETERMINING IF A WELD SHOULD BE SHOWN OR FIELD-WELDED IN ORDER TO FACILITATE THE STRUCTURAL STEEL ERECTION.

SAWN LUMBER SAWN LUMBER SHALL CONFORM TO "GRADING AND DRESSING RULES," WEST COAST LUMBER INSPECTION BUREAU (WCLB), LATEST EDITION. LUMBER SHALL BE ROUGH-CUT AND BE ONE OF THE TWO GRADES LISTED BELOW:

	Fb (PSI)
USE	900
TIMBER LAGGING	900
HEM-FIR NO. 1	975

TIMBER LAGGING SHALL BE PRESERVATIVE TREATED WITH WATERBORNE PRESERVATIVES IN ACCORDANCE WITH AWPA UO4B.

SHORING PROCEDURE

SHAFT DRILLING DRILL PILE AND ANCHOR SHAFTS WITHOUT LOSS OF GROUND AND WITHOUT ENDANGERING PREVIOUSLY INSTALLED PILES AND ANCHORS. SEE THE GEO-TECHNICAL REPORT FOR POSSIBLE OBSTRUCTIONS.

SOLDER PILE PLACEMENT TOLERANCES SOLDER PILES SHALL BE PLACED ACCORDING TO THE MOST STRINGENT OF THE FOLLOWING REQUIREMENTS:

- THE CENTER OF THE PILE IS WITHIN 3 INCHES HORIZONTAL OF THE PLAN LOCATION ALONG THE ENTIRE LENGTH OF THE PILE.
- NO PART EXTENDS MORE THAN 1 1/2 INCHES INTO THE EXCAVATION.
- WITHIN 1% OF PLUMB.
- WITHIN 3 INCHES VERTICAL OF SCHEDULED ELEVATION.

EXCAVATION BELOW TIEBACKS COMPLETE TIEBACK INSTALLATION AND STRESSING PRIOR TO EXCAVATING MORE THAN 2 FOOT BELOW TIEBACK CENTERLINE LEVEL.

LAGGING BACKFILL VOIDS BETWEEN LAGGING AND SOIL IMMEDIATELY AFTER LAGGING INSTALLATION USING A FREE DRAINING BACKFILL MATERIAL, SELECTED BY THE SHORING CONTRACTOR. DRAINAGE BEHIND THE WALL MUST BE MAINTAINED. IT IS THE CONTRACTORS RESPONSIBILITY TO LIMIT THE AMOUNT OF EXPOSED SOIL WITHOUT LAGGING TO AVOID LOSS OF SOIL. LIMIT THE EXCAVATION TO 4 FEET BELOW PREVIOUSLY INSTALLED LAGGING.

TEST REJECTION A TIEBACK MAY BE REJECTED IF IT DOES NOT MEET THE FOLLOWING CRITERION:

- FOR PERFORMANCE TESTS, THE ENGINEER WILL EVALUATE THE RESULTS OF EACH PERFORMANCE TEST. INSTALLATION METHODS THAT DO NOT SATISFY THE TESTING REQUIREMENTS WILL BE REJECTED. THE CONTRACTOR SHALL PROPOSE ALTERNATIVE METHODS AND INSTALL REPLACEMENT VERIFICATION TEST TIEBACKS.
- FOR PROOF TESTS, THE ENGINEER MAY REQUIRE THE CONTRACTOR TO REPLACE SOME OR ALL OF THE INSTALLED PRODUCTION TIEBACKS BETWEEN A FAILED PROOF TEST AND THE ADJACENT PASSING PROOF TEST. ALTERNATIVELY, THE ENGINEER MAY REQUIRE THE INSTALLATION AND TESTING OF ADDITIONAL PROOF TEST TIEBACKS TO VERIFY THE ADJACENT PREVIOUSLY INSTALLED PRODUCTION TIEBACKS HAVE SUFFICIENT LOAD-CARRYING CAPACITY.

TIEBACK LOCK-OFF FOLLOWING SUCCESSFUL PROOF LOADING, LOCK-OFF EACH TIEBACK ANCHOR AT THE LOADS NOTED ON THE PILE AND TIEBACK SCHEDULES. THE MAXIMUM STRESS IN PRESTRESSING STEEL SHALL NOT EXCEED 80 PERCENT OF THE GUTS AT THE DESIGN LOADS.

JACKING AND TEST EQUIPMENT MEASURE THE LOAD ON THE TIEBACKS WITH A PRESSURE GAUGE CALIBRATED WITH THE JACK AND ACCURATE ENOUGH TO READ 100 PSI PRESSURE INCREMENTS. THE PUMP SHALL BE CAPABLE OF APPLYING LOAD INCREMENTS LESS THAN 60 SECONDS.

2. MEASURE THE TIEBACK HEAD MOVEMENT WITH A MINIMUM OF 2 DIAL GAUGES CAPABLE OF MEASURING TO 0.001 INCHES.

3. THE JACK SHALL BE POSITIONED SUCH THAT REPOSITIONING IS NOT REQUIRED DURING TESTING.

PILE BRACING FOR TIEBACK TESTING STEEL BRACING MAY BE REQUIRED DURING TIEBACK STRESSING AND TESTING TO RESTRAIN THE SOLDER PILES FROM THE TIEBACKS AND CONTROL THE OPERATION OF THE BRACING WILL BE DETERMINED IN THE FIELD AT THE TIME OF CONSTRUCTION. THE COST TO FURNISH AND INSTALL THE BRACING WILL BE CONSIDERED INCIDENTAL AND AT NO ADDITIONAL CHARGE TO THE OWNER.

TIEBACK STRESSING AND TESTING

PERFORMANCE TESTING PRIOR TO INSTALLING PRODUCTION TIEBACKS, CONDUCT A MINIMUM OF TWO SUCCESSFUL PERFORMANCE TESTS ON TIEBACKS FOR EACH INSTALLATION METHOD AND SOIL TYPE ENCOUNTERED ON THE PROJECT. INSTALL THE TEST TIEBACKS BY THE SAME METHODS, PERSONNEL, MATERIALS, AND EQUIPMENT AS THE PRODUCTION ANCHORS. CHANGES IN METHODS, PERSONNEL, MATERIALS, OR EQUIPMENT SHALL BE NOTED ON THE DRAWINGS. PERFORMANCE TESTING AS DETERMINED BY THE ENGINEER. PERFORMANCE TESTING AFTER THE GROUT HAS CURED FOR AT LEAST 72 HOURS OR ATTAINED AT LEAST THE SPECIFIED 3-DAY COMPRESSIVE STRENGTH. AN INDEPENDENT TESTING LABORATORY SHALL RECORD ALL TEST DATA.

THE MAXIMUM STRESS IN THE PRESTRESSING STEEL SHALL NOT EXCEED 80 PERCENT OF THE GUARANTEED ULTIMATE TENSILE STRENGTH (GUTS) DURING TESTING. PILES AND TIEBACKS MAY REQUIRE EXTRA REINFORCEMENT TO PERMIT STRESSING TO 100 PERCENT OF THE DESIGN TIEBACK LOAD (DTL) AS REQUIRED BY THE PERFORMANCE TEST. TIEBACK DESIGN TEST LOADS SHALL BE THE DESIGN LOADS SHOWN ON THE DRAWINGS.

CONDUCT THE PERFORMANCE TESTS BY INCREMENTALLY LOADING THE TEST TIEBACKS TO A MAXIMUM TEST LOAD OF 150 PERCENT OF DTL IN ACCORDANCE WITH THE FOLLOWING SCHEDULE. RECORD THE TIEBACK MOVEMENTS AT EACH LOAD INCREMENT.

PERFORMANCE LOAD SCHEDULE					
LOAD CYCLE	APPLIED LOAD	HOLD TIME	RECORD AND PLOT MOVEMENT (in = INCREMENT MOVEMENT Σin = TOTAL MOVEMENT TAKE READINGS AT 1, 2, 3, 4, 5, 6 AND 10 MINUTES	RECORD AND PLOT RESIDUAL MOVEMENT (6in)	CALCULATE AND PLOT ELASTIC MOVEMENT (6en)
CYCLE 1	AL	< 1 MINUTE	-	-	6e1=6i1-6r1
CYCLE 1	0.25DTL	10 MINUTE	61	-	6e2=6i2-6r2
CYCLE 2	AL	< 1 MINUTE	-	6r1	-
CYCLE 2	0.25DTL	< 1 MINUTE	62	-	-
CYCLE 2	0.50DTL	10 MINUTE	62	-	-
CYCLE 3	AL	< 1 MINUTE	-	6r2	6e3=6i3-6r3
CYCLE 3	0.25DTL	< 1 MINUTE	63	-	-
CYCLE 3	0.50DTL	< 1 MINUTE	63	-	-
CYCLE 3	0.75DTL	10 MINUTE	63	-	-
CYCLE 4	AL	< 1 MINUTE	-	6r3	6e4=6i4-6r4
CYCLE 4	0.25DTL	< 1 MINUTE	64	-	-
CYCLE 4	0.50DTL	< 1 MINUTE	64	-	-
CYCLE 4	0.75DTL	< 1 MINUTE	64	-	-
CYCLE 4	1.00DTL	10 MINUTE	64	-	-
CYCLE 5	AL	< 1 MINUTE	-	6r4	6e5=6i5-6r5
CYCLE 5	0.25DTL	< 1 MINUTE	65	-	-
CYCLE 5	0.50DTL	< 1 MINUTE	65	-	-
CYCLE 5	0.75DTL	< 1 MINUTE	65	-	-
CYCLE 5	1.00DTL	< 1 MINUTE	65	-	-
CYCLE 5	1.33DTL (CREEP TEST)	10 MINUTE	65	-	-
CYCLE 6	AL	< 1 MINUTE	-	6r5	6e6=6i6-6r6
CYCLE 6	0.25DTL	< 1 MINUTE	66	-	-
CYCLE 6	0.50DTL	< 1 MINUTE	66	-	-
CYCLE 6	0.75DTL	< 1 MINUTE	66	-	-
CYCLE 6	1.00DTL	< 1 MINUTE	66	-	-
CYCLE 6	1.33DTL	< 1 MINUTE	66	-	-
CYCLE 6	1.50DTL (CREEP TEST)	10 MINUTE	66	-	-
CYCLE 6	AL	< 1 MINUTE	-	6r6	-
LOCK-OFF	ADJUST TO LOCK-OFF IF TEST RESULTS SATISFY ACCEPTANCE CRITERIA	-	-	-	-

APPLY THE MINIMUM ALIGNMENT LOAD (AL) REQUIRED TO ALIGN THE TESTING APPARATUS, NOT TO EXCEED 5 PERCENT OF DTL. SET THE DIAL GAUGES TO "ZERO" AFTER THE ALIGNMENT LOAD HAS BEEN APPLIED. FOLLOWING THE APPLICATION OF THE MAXIMUM LOAD (DTL) (150%), REDUCE THE LOAD TO THE ALIGNMENT LOAD (0.05 DTL, MAXIMUM) AND RECORD THE PERMANENT SET.

START THE PERFORMANCE CREEP TEST PERIOD AS SOON AS THE MAXIMUM TEST LOAD (1.50 DTL) IS APPLIED. MEASURE AND RECORD TIEBACK MOVEMENTS DURING THE CREEP PORTION OF THE TEST IN INCREMENTS OF 1, 2, 3, 4, 5, 6, AND 10 MINUTES. MAINTAIN THE LOAD DURING THE CREEP TEST WITHIN 2 PERCENT OF THE INTENDED LOAD, WHERE THE TIEBACK MOVEMENT BETWEEN 1 MINUTE AND 10 MINUTES EXCEEDS 0.4 INCHES. MAINTAIN THE MAXIMUM TEST LOAD FOR AN ADDITIONAL 20 MINUTES AND RECORD TIEBACK MOVEMENTS AT 20, 30, 40, 50, AND 60 MINUTES. PERFORMANCE TESTED TIEBACKS MAY BE USED AS PRODUCTION TIEBACKS IF THEY FULLY MET THE ACCEPTANCE CRITERIA NOTED BELOW AND UPON APPROVAL BY THE ENGINEER.

PROOF TESTING COMPLETE PROOF TESTS ON ALL PRODUCTION TIEBACKS NOT SUBJECT TO A PERFORMANCE TEST. THE MAXIMUM STRESS IN PRESTRESSING STEEL SHALL NOT EXCEED 80 PERCENT OF GUTS DURING TESTING. USE THE DTL SHOWN ON THE DRAWINGS.

CONDUCT THE PROOF TESTS BY INCREMENTALLY LOADING THE TEST TIEBACKS TO A MAXIMUM TEST LOAD OF 150 PERCENT OF DTL IN ACCORDANCE WITH THE FOLLOWING SCHEDULE. RECORD THE TIEBACKS MOVEMENTS AT EACH LOAD INCREMENT.

PROOF TEST SCHEDULE					
LOAD INCREMENT	APPLIED LOAD	HOLD TIME	RECORD AND PLOT MOVEMENT (in = INCREMENT MOVEMENT Σin = TOTAL MOVEMENT TAKE READINGS AT 1, 2, 3, 4, 5, 6 AND 10 MINUTES		
INCREMENT 1	ALIGNMENT LOAD (AL)	< 1 MINUTE	-	-	-
INCREMENT 1	0.25 DESIGN LOAD (DTL)	< 1 MINUTE	61	-	-
INCREMENT 2	0.50DTL	< 1 MINUTE	62	-	-
INCREMENT 3	0.75DTL	< 1 MINUTE	63	-	-
INCREMENT 4	1.00DTL	< 1 MINUTE	64	-	-
INCREMENT 5	1.20DTL	< 1 MINUTE	65	-	-
INCREMENT 6	1.33DTL (CREEP TEST)	10 MINUTES	66	-	-
LOCK-OFF	ADJUST TO LOCK-OFF IF TEST RESULTS SATISFY ACCEPTANCE CRITERIA	-	-	-	-

APPLY THE MINIMUM ALIGNMENT LOAD (AL) REQUIRED TO ALIGN THE TESTING APPARATUS, NOT TO EXCEED 5 PERCENT OF DTL. SET THE DIAL GAUGES TO "ZERO" AFTER THE ALIGNMENT LOAD HAS BEEN APPLIED.

START THE PROOF CREEP TEST PERIOD AS SOON AS THE MAXIMUM TEST LOAD (1.33DTL) IS APPLIED. MEASURE AND RECORD TIEBACK MOVEMENTS DURING THE CREEP PORTION OF THE TEST IN INCREMENTS OF 1, 2, 3, 4, 5, 6, AND 10 MINUTES. MAINTAIN THE LOAD DURING THE CREEP TEST WITHIN 2 PERCENT OF THE INTENDED LOAD, WHERE THE TIEBACK MOVEMENT BETWEEN 1 MINUTE AND 10 MINUTES EXCEEDS 0.4 INCHES. MAINTAIN THE MAXIMUM TEST LOAD FOR AN ADDITIONAL 20 MINUTES AND RECORD TIEBACK MOVEMENTS AT 20, 30, 40, 50, AND 60 MINUTES.

TEST TIEBACK ACCEPTANCE CRITERIA

- A TEST TIEBACK IS CONSIDERED ACCEPTABLE WHEN ALL OF THE FOLLOWING CRITERIA ARE MET:
- FOR PERFORMANCE TESTS, THE TOTAL CREEP MOVEMENT IS LESS THAN 0.04 INCHES BETWEEN THE 1 AND 10 MINUTE READINGS OR THE TOTAL CREEP MOVEMENT IS LESS THAN 0.08 INCHES BETWEEN THE 1 AND 10 MINUTE READINGS, AND THE CREEP RATE IS LINEAR OR DECREASING THROUGHOUT THE CREEP TEST LOAD HOLD PERIOD.
 - FOR PROOF TESTS, THE TOTAL CREEP MOVEMENT IS LESS THAN 0.04 INCHES BETWEEN 1 AND 10 MINUTES, OR THE TOTAL CREEP MOVEMENT IS LESS THAN 0.08 INCHES BETWEEN 1 AND 10 MINUTES READINGS, AND THE CREEP RATE IS LINEAR OR DECREASING THROUGHOUT THE CREEP TEST LOAD HOLD PERIOD.
 - FOR PERFORMANCE AND PROOF TESTS, THE TOTAL MEASURED MOVEMENT AT THE MAXIMUM TEST LOAD EXCEEDS 80 PERCENT OF THE THEORETICAL ELASTIC ELONGATION OF THE UNBONDED LENGTH.
 - A PULLOUT FAILURE DOES NOT OCCUR. PULL-OUT FAILURE IS DEFINED AS THE INABILITY TO FURTHER INCREASE THE TEST LOAD WHILE THERE IS CONTINUED PULLOUT MOVEMENT OF THE TEST TIEBACK OR THE NON-ELASTIC MOVEMENT EXCEEDS 2 INCHES. RECORD THE PULL-OUT FAILURE LOAD AS PART OF THE TEST DATA.

MAINTAINING STABILITY OF THE TEMPORARY UNBONDED TEST LENGTH FOR SUBSEQUENT GROUTING IS THE CONTRACTORS RESPONSIBILITY. IF THE UNBONDED TEST LENGTH OF PRODUCTION PROOF TEST TIEBACKS CANNOT BE SATISFACTORILY GROUTED SUBSEQUENT TO TESTING, THE PROOF TEST TIEBACK SHALL BECOME SACRIFICIAL AND SHALL BE REPLACED.

TEST REJECTION

- FOR PERFORMANCE TESTS, THE ENGINEER WILL EVALUATE THE RESULTS OF EACH PERFORMANCE TEST. INSTALLATION METHODS THAT DO NOT SATISFY THE TESTING REQUIREMENTS WILL BE REJECTED. THE CONTRACTOR SHALL PROPOSE ALTERNATIVE METHODS AND INSTALL REPLACEMENT VERIFICATION TEST TIEBACKS.
- FOR PROOF TESTS, THE ENGINEER MAY REQUIRE THE CONTRACTOR TO REPLACE SOME OR ALL OF THE INSTALLED PRODUCTION TIEBACKS BETWEEN A FAILED PROOF TEST AND THE ADJACENT PASSING PROOF TEST. ALTERNATIVELY, THE ENGINEER MAY REQUIRE THE INSTALLATION AND TESTING OF ADDITIONAL PROOF TEST TIEBACKS TO VERIFY THE ADJACENT PREVIOUSLY INSTALLED PRODUCTION TIEBACKS HAVE SUFFICIENT LOAD-CARRYING CAPACITY.

TIEBACK LOCK-OFF

FOLLOWING SUCCESSFUL PROOF LOADING, LOCK-OFF EACH TIEBACK ANCHOR AT THE LOADS NOTED ON THE PILE AND TIEBACK SCHEDULES. THE MAXIMUM STRESS IN PRESTRESSING STEEL SHALL NOT EXCEED 80 PERCENT OF THE GUTS AT THE DESIGN LOADS.

JACKING AND TEST EQUIPMENT

- MEASURE THE LOAD ON THE TIEBACKS WITH A PRESSURE GAUGE CALIBRATED WITH THE JACK AND ACCURATE ENOUGH TO READ 100 PSI PRESSURE INCREMENTS. THE PUMP SHALL BE CAPABLE OF APPLYING LOAD INCREMENTS LESS THAN 60 SECONDS.
- MEASURE THE TIEBACK HEAD MOVEMENT WITH A MINIMUM OF 2 DIAL GAUGES CAPABLE OF MEASURING TO 0.001 INCHES.
- THE JACK SHALL BE POSITIONED SUCH THAT REPOSITIONING IS NOT REQUIRED DURING TESTING.

PILE BRACING FOR TIEBACK TESTING

STEEL BRACING MAY BE REQUIRED DURING TIEBACK STRESSING AND TESTING TO RESTRAIN THE SOLDER PILES FROM THE TIEBACKS AND CONTROL THE OPERATION OF THE BRACING WILL BE DETERMINED IN THE FIELD AT THE TIME OF CONSTRUCTION. THE COST TO FURNISH AND INSTALL THE BRACING WILL BE CONSIDERED INCIDENTAL AND AT NO ADDITIONAL CHARGE TO THE OWNER.

SHORING MONITORING

PRECONSTRUCTION SURVEY PRIOR TO CONSTRUCTION, COMPLETE A WRITTEN AND PHOTOGRAPHIC LOG OF EXISTING CONDITIONS OF THE ADJACENT CONSTRUCTION AND SITE IMPROVEMENTS THAT MIGHT BE MISCONSTRUED AS DAMAGE CAUSED BY THE ABSENCE OF, OR THE INSTALLATION OF, OR THE PERFORMANCE OF EXCAVATION SUPPORT AND PROTECTION SYSTEMS. A LICENSED SURVEYOR SHALL DOCUMENT ALL EXISTING SUBSTANTIAL CRACKS IN ADJACENT STREETS, SIDEWALKS, AND EXISTING STRUCTURES. CRACK GAUGES MAY BE REQUIRED BY THE ENGINEER.

OPTICAL SURVEY SURVEY THE VERTICAL AND HORIZONTAL DISPLACEMENT AT THE TOP OF EVERY OTHER SOLDER PILE.

ESTABLISH SURVEY LINES NEAR THE TOP OF THE WALL AND AT DISTANCES UP TO THE WALL HEIGHT, H, BEHIND THE WALL FACE. SPACE THESE POINTS A MAXIMUM OF 50 FEET APART. FOLLOW THE RECOMMENDATIONS OF THE GEO-TECHNICAL ENGINEER OF RECORD FOR ESTABLISHING THE SPACING AND LOCATION OF THE MONITORING POINTS.

ESTABLISH A BASELINE READING OF THE MONITORING POINTS ON THE GROUND SURFACE BEHIND THE SHORING WALLS BEFORE INSTALLING THE SHORING. ESTABLISH A BASELINE READING OF THE SURVEY POINTS ON THE SOLDER PILES PRIOR TO BEGINNING EXCAVATION.

THE GEO-TECHNICAL ENGINEER SHALL REVIEW SURVEY DATA AND PROVIDE AN EVALUATION OF WALL PERFORMANCE ALONG WITH SURVEY DATA TO THE AUTHORITY HAVING JURISDICTION (AHJ) ON AT LEAST A WEEKLY BASIS. IMMEDIATELY AND DIRECTLY NOTIFY THE AHJ IF ANY UNUSUAL OR SIGNIFICANTLY INCREASED MOVEMENT OCCURS.

MONITORING OF THE SURVEY POINTS SHALL INCLUDE VERTICAL AND HORIZONTAL MEASUREMENTS ACCURATE TO AT LEAST 0.01 FEET. THE FREQUENCY OF THE READINGS IS DEPENDENT ON THE CONSTRUCTION STAGE, AS NOTED BELOW.

OPTICAL SURVEY SCHEDULE	
CONSTRUCTION STAGE	MONITORING FREQUENCY
DURING EXCAVATION AND UNTIL WALL MOVEMENTS HAVE STABILIZED	TWICE WEEKLY
DURING EXCAVATION IF LATERAL WALL MOVEMENTS EXCEED 1/2 INCH, OR AT THE DISCRETION OF THE ENGINEER	GEO-TECHNICAL AND SHORING ENGINEER TO EVALUATE

AFTER EXCAVATION IS COMPLETE AND WALL MOVEMENTS HAVE STABILIZED, IF THE DATA INDICATES LITTLE OR NO MOVEMENT.

SUBMIT SURVEY DATA TO THE GEO-TECHNICAL ENGINEER, SHORING ENGINEER, AND THE AHJ EACH WEEK. NOTIFY THE AHJ IMMEDIATELY IF ANY UNUSUAL OR SIGNIFICANTLY INCREASED MOVEMENTS OCCUR.

SURVEYING MUST CONTINUE UNTIL THE PERMANENT STRUCTURE IS COMPLETE UP TO FINAL STREET GRADES. TERMINATION OF SURVEY MONITORING WILL BE DETERMINED BY THE GEO-TECHNICAL ENGINEER AFTER REVIEW AND APPROVAL BY THE AHJ.

INCLINOMETERS PROVIDE AND INSTALL INCLINOMETER CASING ON SOLDER PILES SELECTED BY THE GEO-TECHNICAL ENGINEER TO FACILITATE MEASUREMENT OF WALL DEFLECTIONS AS THE EXCAVATION AND SHORING INSTALLATION PROCEEDS.

PROVIDE INCLINOMETER CASINGS CONSISTING OF 2 7/8 INCH ODB ABS PLASTIC PIPE WITH INTERNAL LONGITUDINAL GROOVES, AS SUPPLIED BY SLOPE INDICATOR COMPANY (SINC) OR APPROVED EQUAL. PROVIDE SELF-ALIGNING COUPLERS, CAPS AND FITTINGS AND ALL NECESSARY INSTALLATION TOOLS AND ACCESSORIES.

FIRMLY ATTACH INCLINOMETER CASINGS TO THE BACK FACE OF THE STEEL SOLDER PILE PER DETAIL 130H-01. AFFIX THE BOTTOM OF THE CASING APPROXIMATELY 2 FEET ABOVE THE BOTTOM OF THE SOLDER PILE. THE TOP OF THE CASING SHALL EXTEND AT LEAST 1 FOOT ABOVE THE TOP OF THE SOLDER PILE.

SECURE THE CASING TO THE STEEL SOLDER PILE ON MAXIMUM 6 FOOT CENTERS USING C-CLIPS OR STEEL STRIPS TACKLED TO THE FLANGE. PROTECT CASING FROM DAMAGE DURING THE WELDING OPERATIONS. INSTALL THE CASINGS WITH NOT MORE THAN 3" OF TWIST OR DIAL ROTATION BETWEEN TOP AND BOTTOM GROOVES ON THE INSIDE OF THE CASING MUST BE ORIENTED SO THAT THE ORTHOGONAL GROOVES ARE POSITIONED PARALLEL AND PERPENDICULAR AT THE EXCAVATION. TIGHTLY CAP CASINGS AT EACH END PRIOR TO ATTACHMENT TO THE STEEL BEAM TAPE ALL JOINTS TO PREVENT INTRUSION OF GROUT. FILL CASINGS WITH CLEAN WATER PRIOR TO INSERTION INTO PILE HOLE. INSTALL ALL INCLINOMETER CASING IN THE PRESENCE OF AND WITH APPROVAL OF THE GEO-TECHNICAL ENGINEER.

SHORING WALL DEFLECTION LIMITS AND MITIGATION MEASURES

IF LATERAL MOVEMENTS OF THE SHORING WALL ARE OBSERVED TO EXCEED 0.5 INCH WHERE ABUTTING CITY RIGHT-OF-WAYS OR PRIVATE PROPERTIES, STOP CONSTRUCTION OF THE SHORING WALL IN THE VICINITY OF THE AFFECTED PORTION OF THE SHORING WALL IMMEDIATELY AND DIRECTLY NOTIFY THE GEO-TECHNICAL AND STRUCTURAL ENGINEERS, WALL DESIGNER, SOCI, AND SDOT IF 0.5 INCH OF MOVEMENT OCCURS BETWEEN TWO CONSECUTIVE READINGS AND WHEN TOTAL MOVEMENTS REACH 0.5 INCH. AT THAT AMOUNT OF MOVEMENT, THE CONTRACTOR, ENGINEER, AND GEO-TECHNICAL ENGINEER SHALL DETERMINE THE CAUSE OF DISPLACEMENT AND DEVELOP REMEDIAL MEASURES SUFFICIENT TO LIMIT TOTAL WALL MOVEMENTS TO 1 INCH. THESE MEASURES MAY CONSIST OF INTERNAL BRACING (I.E. WALES AND RIGGERS), ADDITIONAL TIEBACKS AND/OR SOIL BEHIND. IMPLEMENTATION OF THE MITIGATION MEASURES WILL BE CONSIDERED AT THAT TIME.

THE FREQUENCY OF THE SHORING SURVEY MONITORING PROGRAM WILL BE ALTERED DEPENDING ON HOW MUCH MOVEMENT IS OBSERVED. AT MINIMUM, THE MONITORING WILL BE INCREASED TO ONCE PER DAY UNTIL DIRECTED OTHERWISE BY THE GEO-TECHNICAL ENGINEER.

IMPLEMENT THE MITIGATION MEASURES DEVELOPED ABOVE IF 1 INCH LATERAL DEFLECTION IS EXCEEDED FOR SHORING SYSTEMS RETAINING CITY RIGHT-OF-WAYS. BERM SOIL AGAINST THE SUBJECT WALL TO ARREST THE WALL MOVEMENT UNTIL THE MITIGATION MEASURES ARE IMPLEMENTED. NOTIFY SOCI AND SDOT IMMEDIATELY OF THE OCCURRENCE OF THESE EVENTS.

PRECONSTRUCTION MEETING

A PRE-CONSTRUCTION MEETING WITH SDOT SHORING REVIEW AND INSPECTION, SEPARATE FROM ANY SOCI PRE-CONSTRUCTION MEETING, WILL BE REQUIRED PRIOR TO THE START OF EXCAVATIONS ADJACENT TO THE PUBLIC ROW. ATTENDEES SHALL INCLUDE REPRESENTATIVES OF THE OWNER, ARCHITECT, GENERAL CONTRACTOR, EXCAVATION AND SHORING CONTRACTORS, THE PROJECT GEO-TECHNICAL ENGINEER, PROJECT SURVEYORS, AND SDOT SHORING REVIEW AND INSPECTION PERSONNEL.

PAINTING

STEEL PAINTING PAINT PERMANENT SOLDER PILES WITH THE FOLLOWING PAINTING SYSTEM WHERE EXPOSED TO WEATHER.

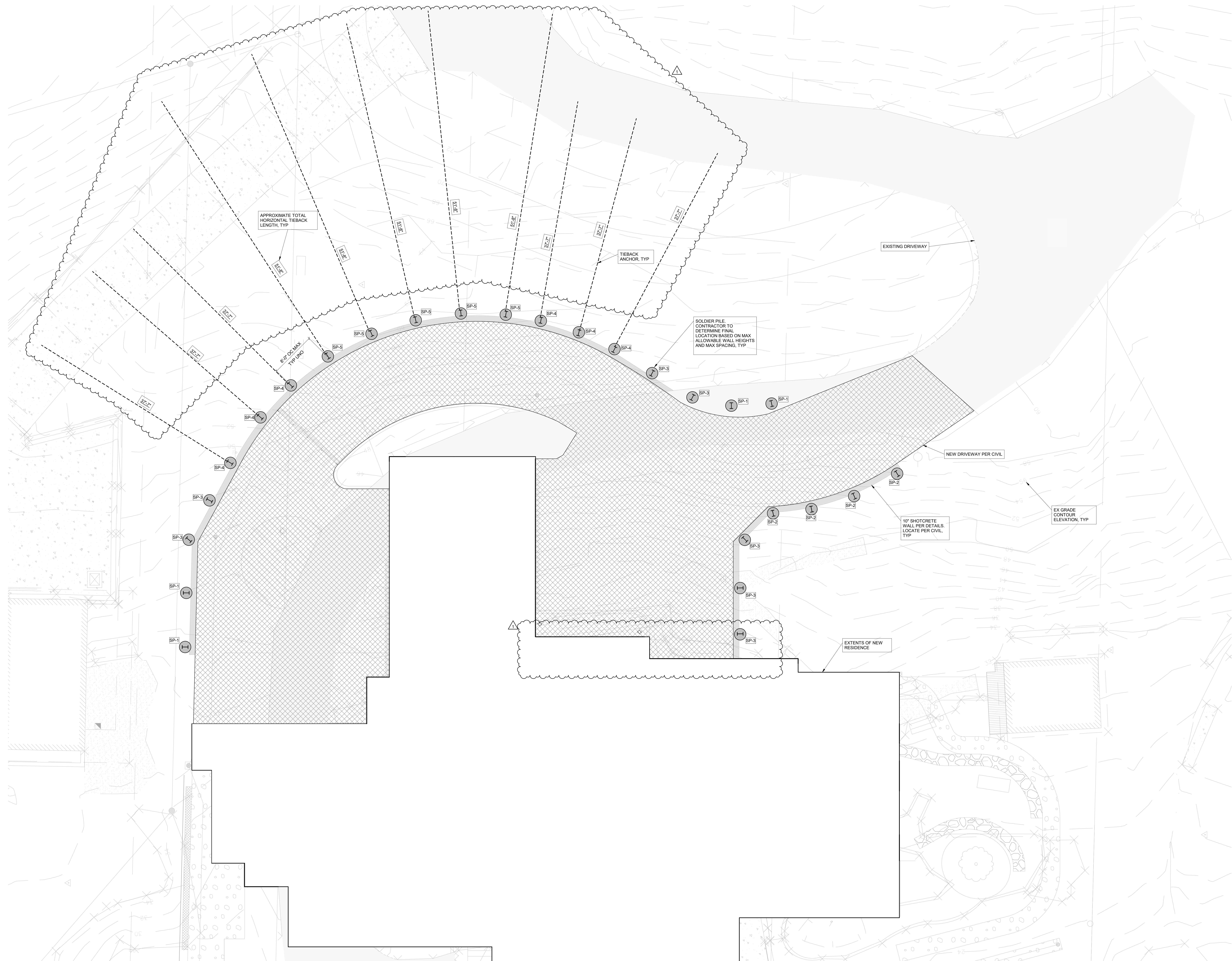

- SHORING PLAN NOTES:**
1. DIMENSIONS OF BUILDING STRUCTURE ARE FOR REFERENCE ONLY. COORDINATE ALL WORK WITH STRUCTURAL AND ARCHITECTURAL DRAWINGS.
 2. PILES ARE ASSUMED TO BE INSTALLED FROM EXISTING GRADE (±).
 3. TRAFFIC AND CONSTRUCTION LOADING IS INDICATED ON THE SHORING NOTES.
 4. SP-X INDICATES SOLDIER PILE TYPE PER 19SH4.01



stamp/seal:

kpff

1601 Fifth Avenue, Suite 1600
 Seattle, WA 98101
 206.622.5822
 kpff.com

project engineer: CBL
 project manager: JRS
 drawn by: RMF
 checked by: AES
 job no.: 220638

revisions:

no.	date	description
1	02/23/24	R1

PERMIT
 09/08/2023

sheet:
SH2.01

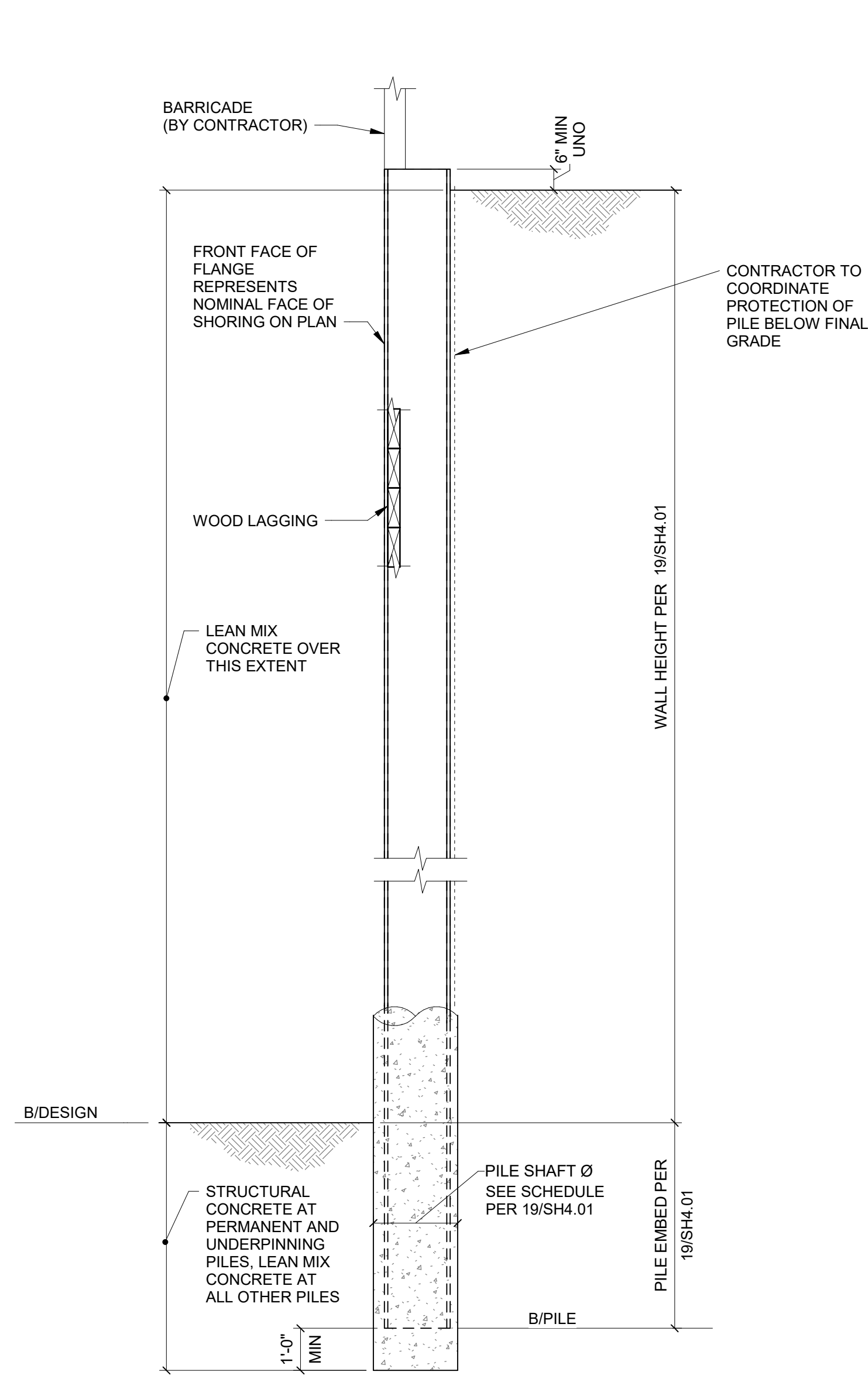

6 TYP CANTILEVERED SOLDIER PILE SECTION
NO SCALE

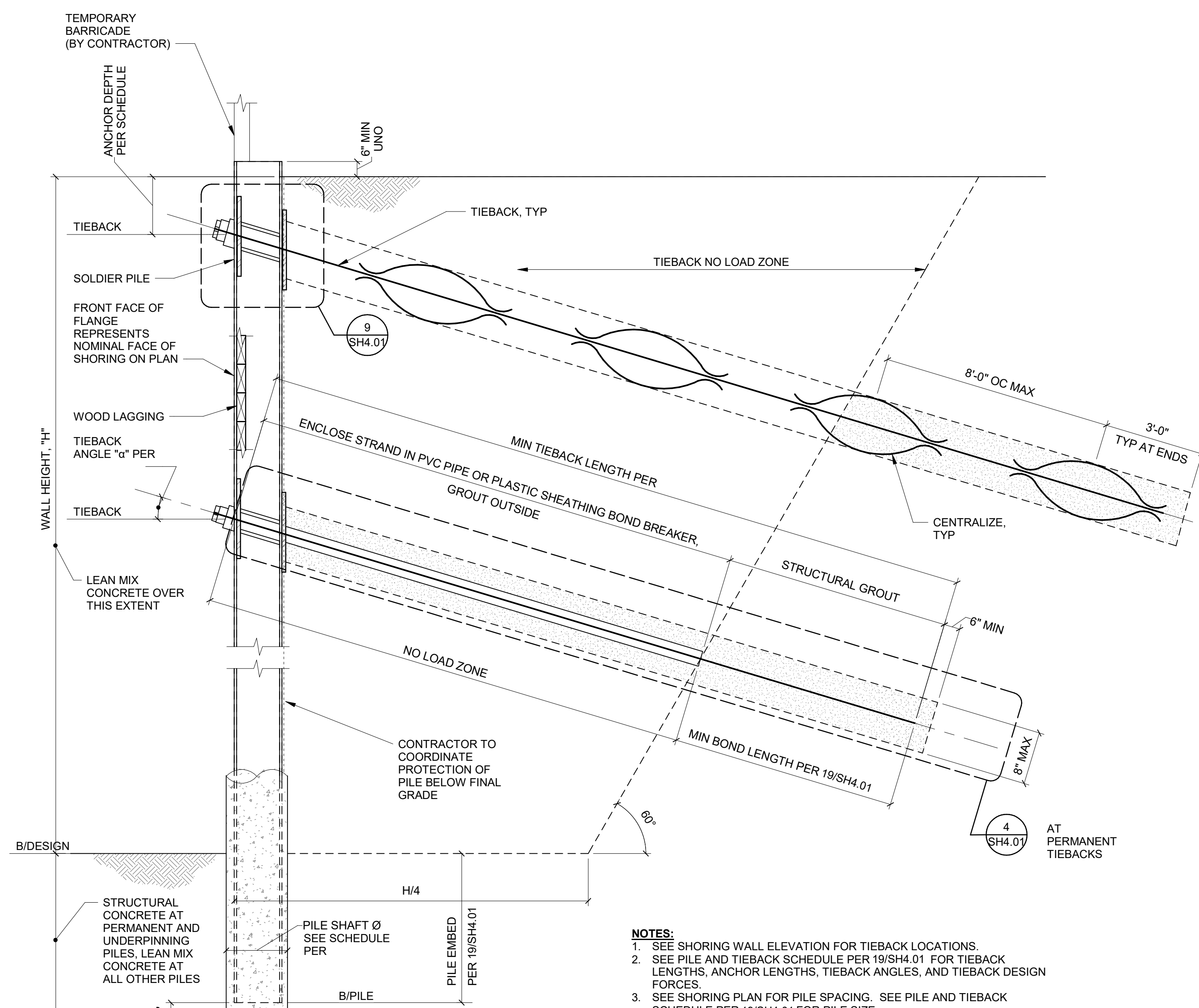

7 TYP SOLDIER PILE AND TIEBACK SECTION
NO SCALE

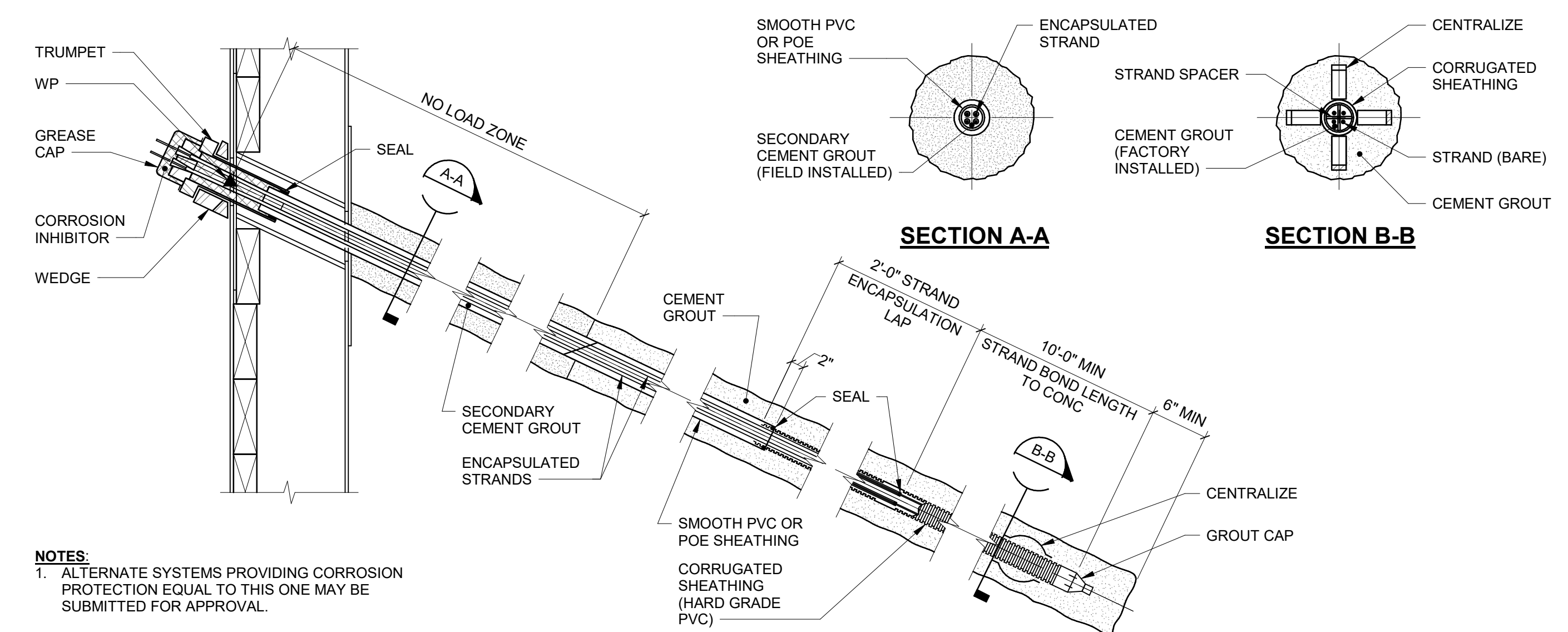

4 TYP PERMANENT TIEBACK SECTION
NO SCALE

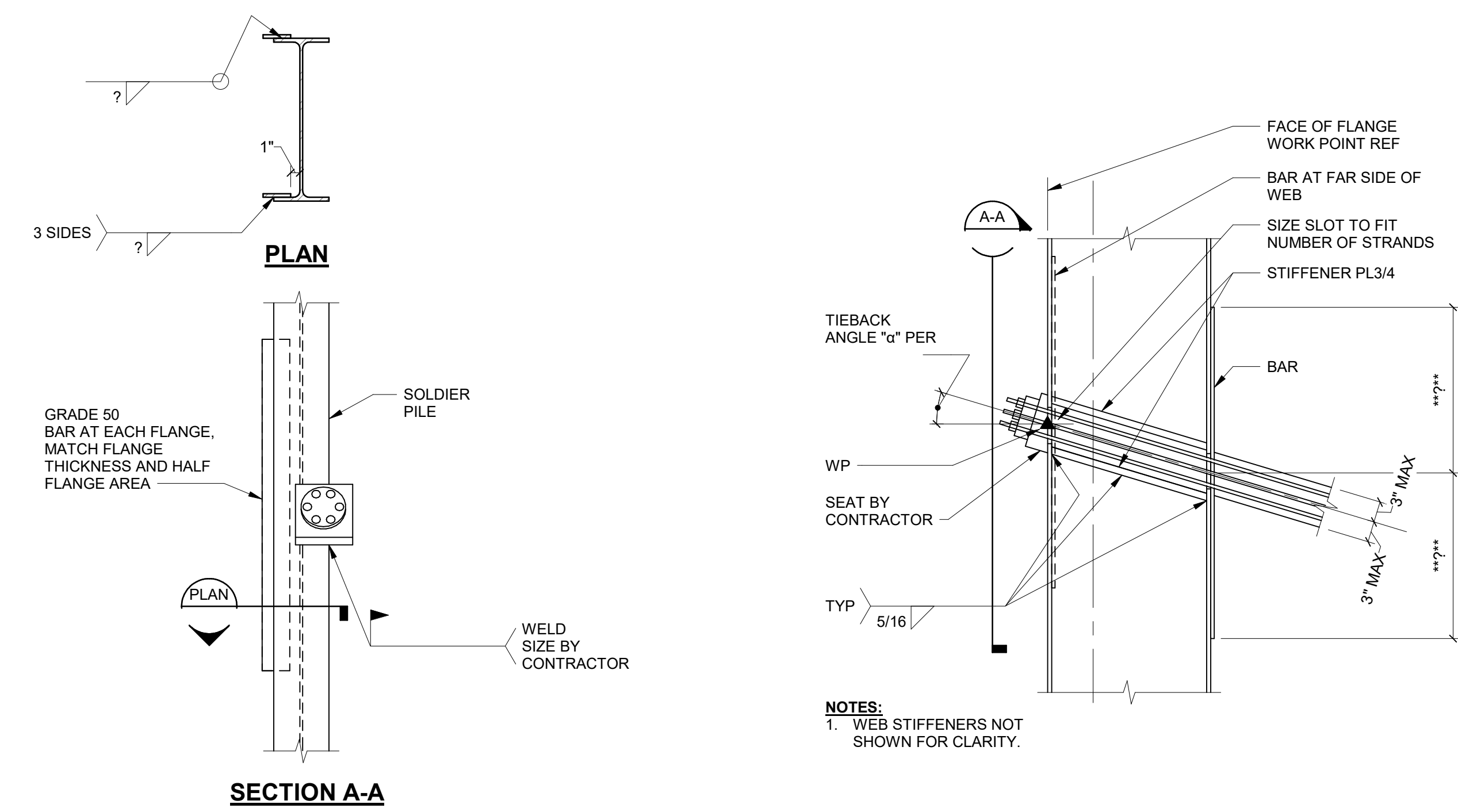

9 TYP TIEBACK ANCHORAGE
NO SCALE

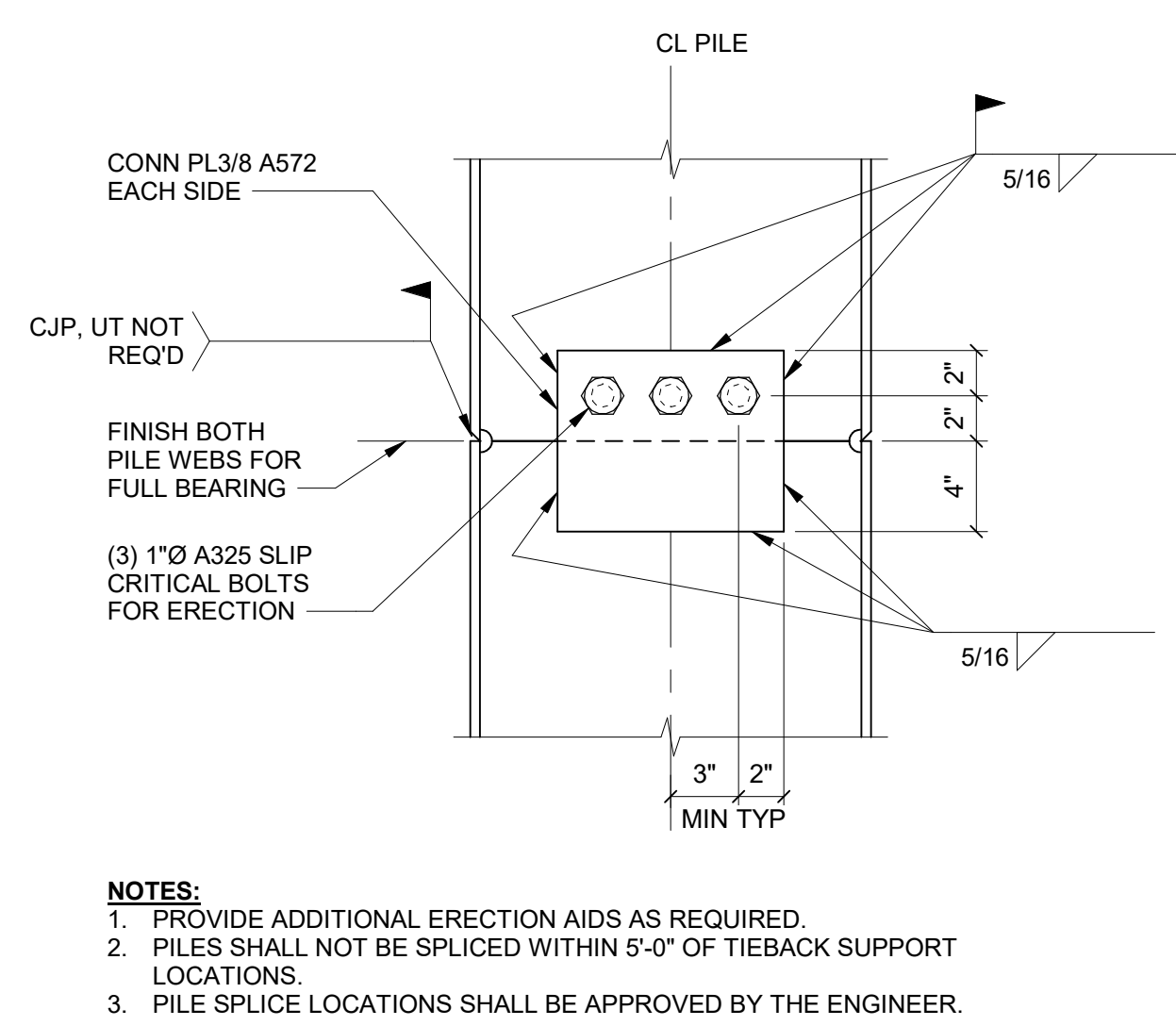

11 TYP SOLDIER PILE SPLICE
NO SCALE

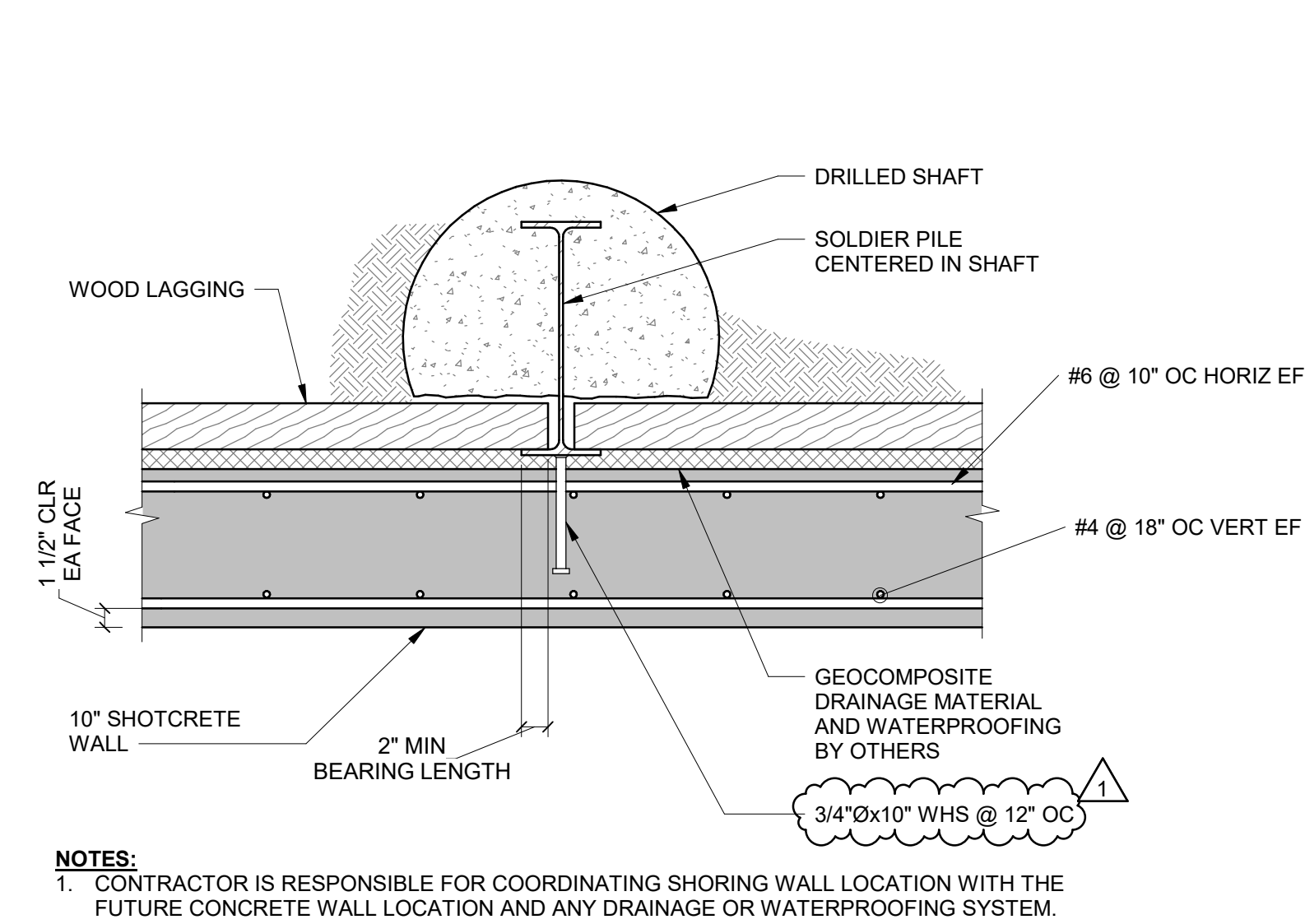

12 TYP SOLDIER PILE DETAIL
NO SCALE

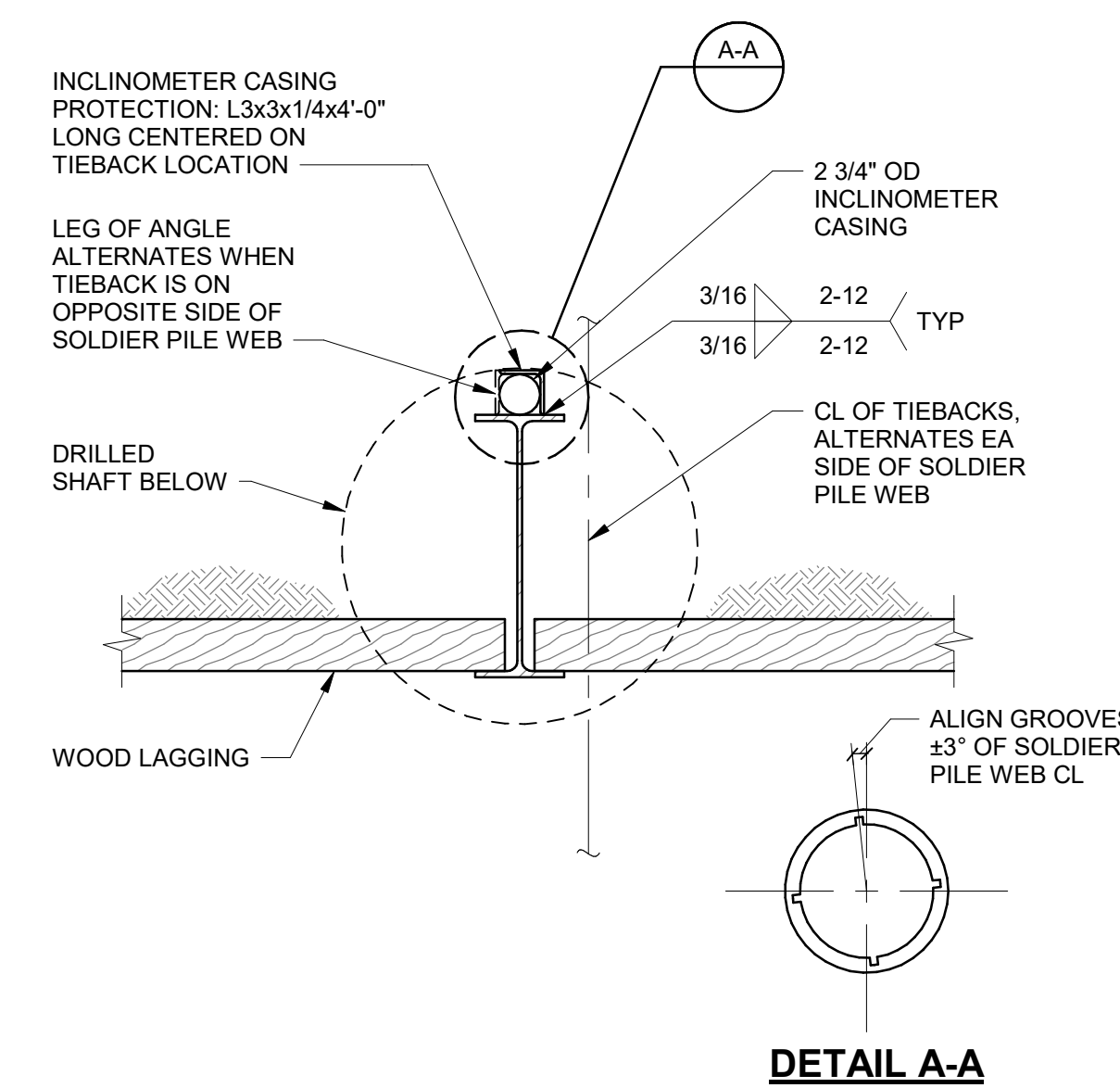

13 TYP DETAIL AT INCLINOMETER
NO SCALE

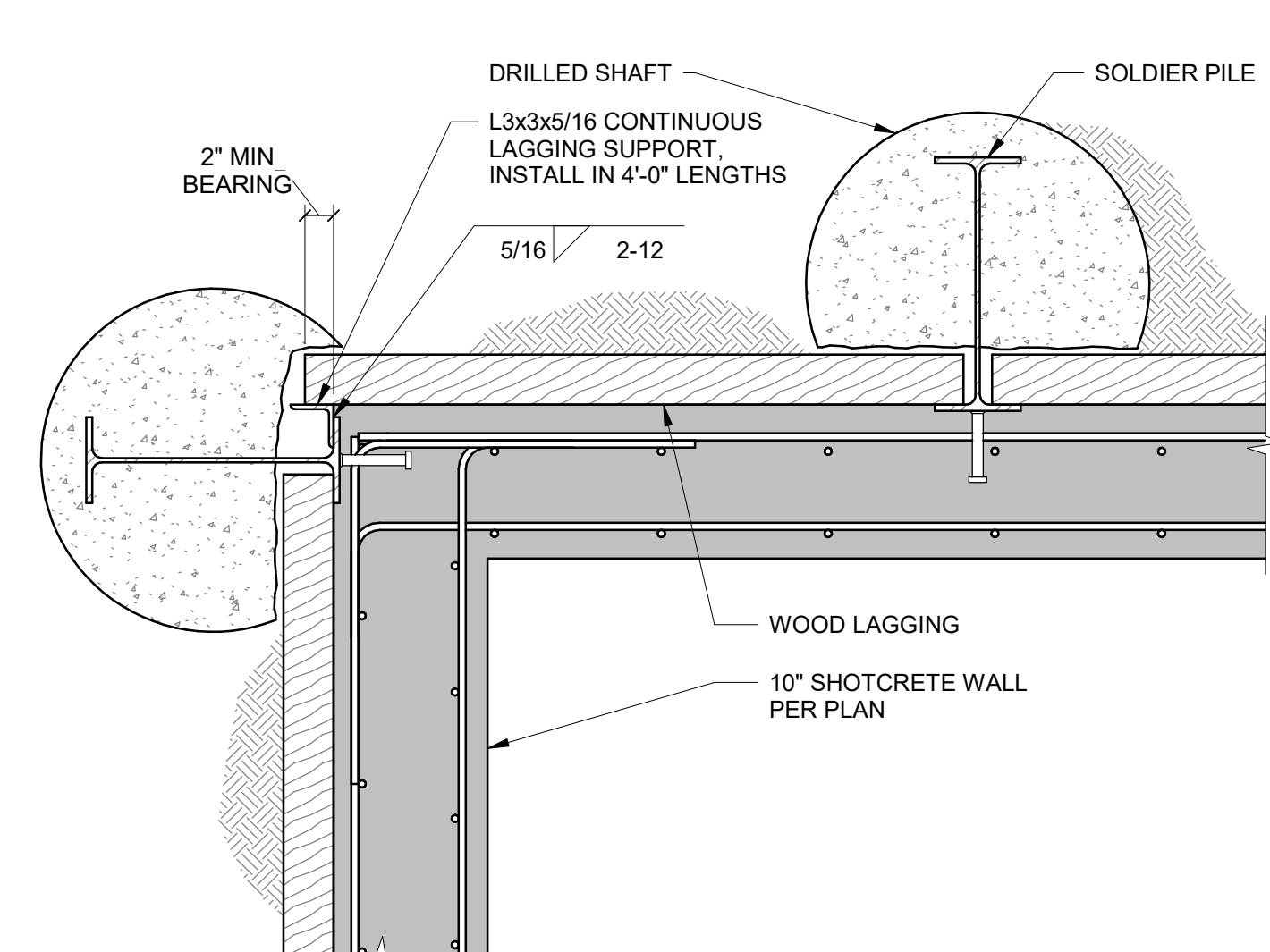

16 LAGGING DETAIL (INSIDE CORNER)
NO SCALE

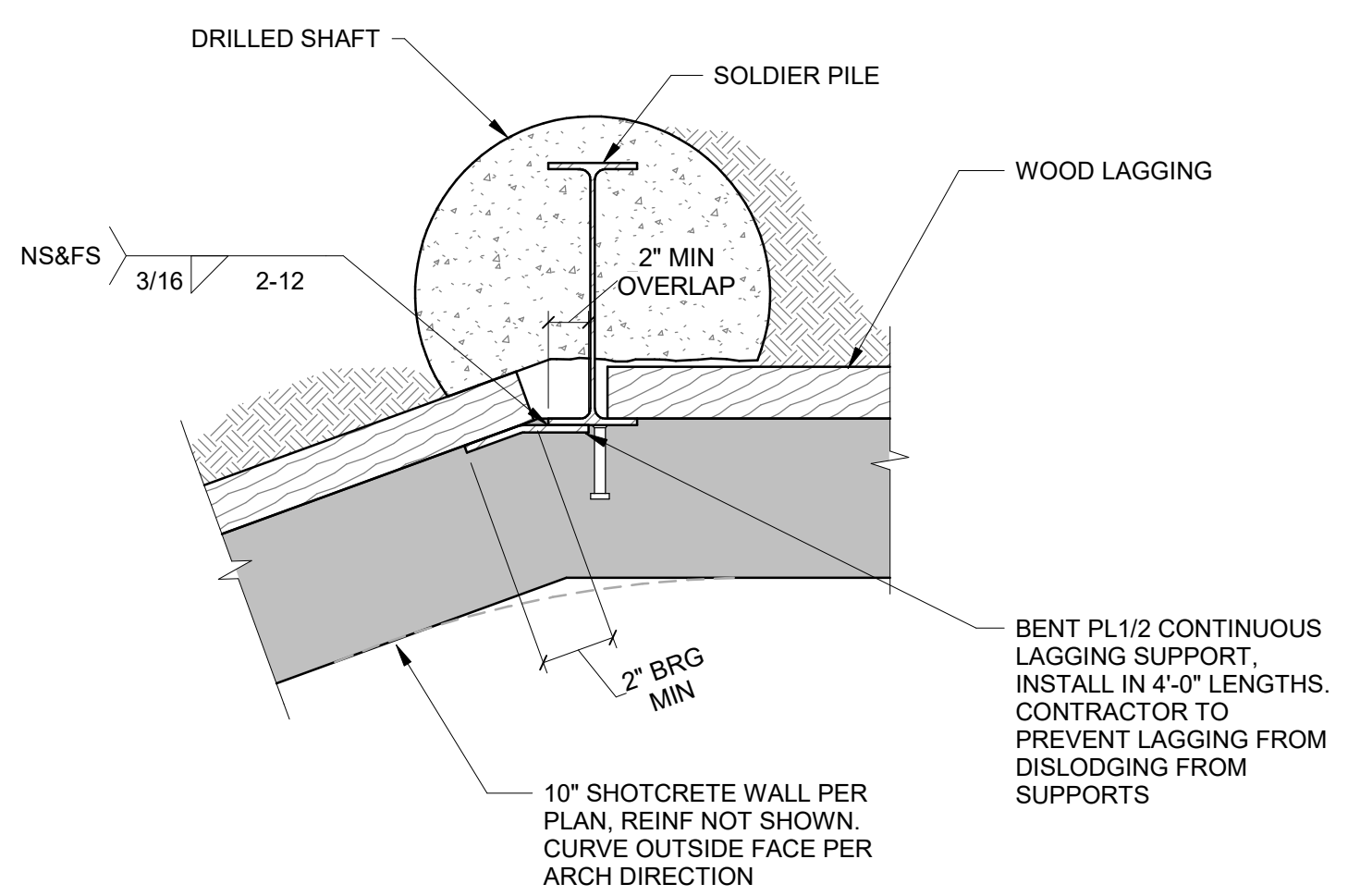

17 SHORING WALL BEND DETAIL
NO SCALE

SHORING WALL PILE AND TIEBACK SCHEDULE					
PILE NUMBER	SP-1	SP-2	SP-3	SP-4	SP-5
W SECTION	W12x30	W12x30	W12x106	W12x53	W12x67
MAX WALL HEIGHT (FT)	6	6	10	17	21
EMBED DEPTH (FT)	12.5	14.5	19.5	30	10
PILE LENGTH (FT)	18.5	20.5	29.5	27	31
DRILLED SHAFT DIA (IN)	24	24	24	24	24
ANCHOR DEPTH (FT)	-	-	-	7	9
θ (DEG)	-	-	-	20	20
TIEBACK LENGTH (FT)	-	-	-	40	55
BOND LENGTH (FT)	-	-	-	27	41
# 6.6-IN DIA STRANDS	-	-	-	3	4
DESIGN LOAD (K)	-	-	-	84	127
KICKOFF LOAD (K)	-	-	-	84	127

19 SHORING WALL PILE AND TIEBACK SCHEDULE
NO SCALE



stamp: seal

1601 Fifth Avenue, Suite 1600
Seattle, WA 98101
206.622.5822
kpff.com

project engineer: CBL
project manager: JRS
drawn by: BMF
checked by: AES
job no.: 220638

revisions:

1	02/23/24	R1	
no.	date:	description:	

PERMIT
09/08/2023

TYPICAL SHORING DETAILS

sheet: **SH4.01**

LEGEND

Table with two columns: Abbreviation and Description. Includes items like ACU (AIR CONDITIONING UNIT), AHU (AIR HANDLING UNIT), and various pipe symbols.

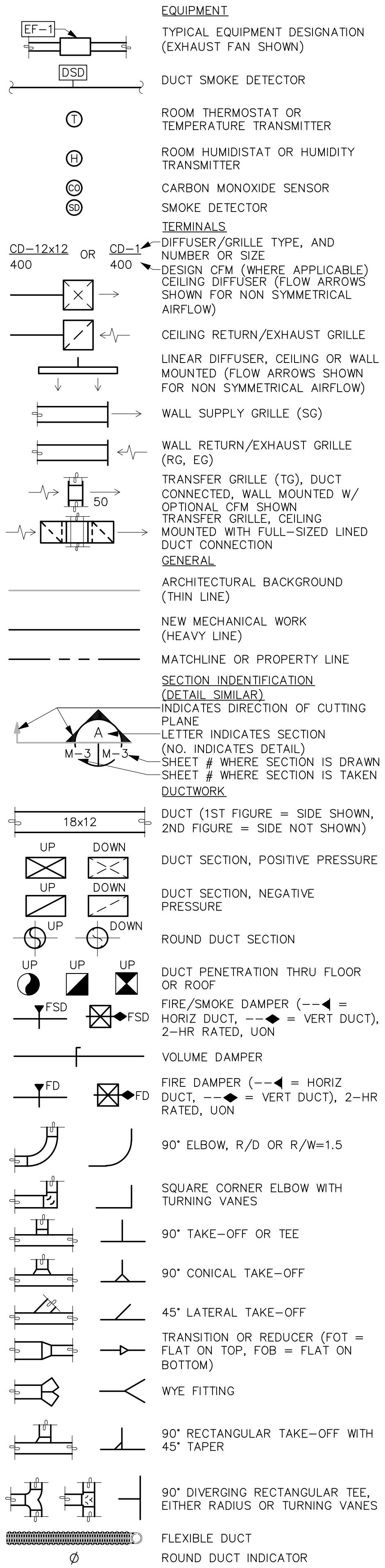

GENERAL NOTES

GENERAL NOTES - MECHANICAL
1. REFERENCE TO RELATED WORK: "RF" INDICATIONS DENOTE WORK COVERED ELSEWHERE...
2. ELECTRICAL CHARACTERISTICS: REFER TO ELECTRICAL DRAWINGS FOR ELECTRICAL CHARACTERISTICS...
3. CODES: COMPLETE INSTALLATION OF THE MECHANICAL SYSTEM SHALL BE PER THE APPLICABLE BUILDING, MECHANICAL, ENERGY, PLUMBING, FIRE, AND HEALTH CODES...
4. PREPARE AND SUBMIT FOR REVIEW A SHOP DRAWING BASED ON FINAL STRUCTURAL SHOP DRAWINGS FOR LOCATING AND ROUTING ALL DUCTWORK, DAMPERS, EQUIPMENT, PIPING, ETC.

PRE-CON MEETING

CONTRACTORS SHALL ATTEND A PRE-CONSTRUCTION MEETING WITH THE ENGINEER FOR THE PURPOSE OF REVIEWING THE WORK PRIOR TO ORDERING ANY EQUIPMENT OR PERFORMING ANY WORK... THE MEETING SHALL BE LOCATED AT THE PROJECT SITE ON A DATE AND TIME TO BE MUTUALLY AGREED.

APPLICABLE CODES

THESE DRAWINGS ARE BASED ON THE FOLLOWING CODES:
-2018 INTERNATIONAL RESIDENTIAL CODE (WITH STATE OF WASHINGTON AMENDMENTS)
-2018 UNIFORM PLUMBING CODE (WITH STATE OF WASHINGTON AMENDMENTS)
-2018 WASHINGTON STATE ENERGY CODE - RESIDENTIAL PROVISIONS

Olson Kundig logo and address: 1591 Boren Johnson Dr, Suite 100, Seattle, Washington 98148 USA



Professional Engineer seal for Robison Engineering, Inc. No. 1216-001, State of Washington, expires 2/23/24.

project architect: JAN
project manager: JAN
drawn by: JAN
checked by: FR
job no.: 1216-001

Revisions table with columns: no., date, description. Row 1: 1, 2/23/24, PERMIT REVISION SET.

DRAWING INDEX

Table with columns: DWG, DESCRIPTION, INCLUDED IN SET, SHEETS WITH REVISIONS. Lists drawings M0.00 through M5.00.

no.: date: description:
NOT FOR CONSTRUCTION
PERMIT SET
2/23/2024

title:
LEGEND, GENERAL NOTES, DRAWING INDEX

sheet:
M0.00

SCHEDULES

EQUIP. NO.	SERVICE	MOUNTING/DISCHARGE	SPLIT SYSTEM HEAT PUMP SCHEDULE – INDOOR UNIT								BASIS OF DESIGN	CONNECTED OUTDOOR UNIT		
			FAN		AUX. HEAT		ELECTRICAL		FAN COIL					
			AIRFLOW, CFM	ESP. IN WG	MIN. OSA, (1)	HEAT, KW (240V)	VOLTAGE	MCA	MCOCP	(2)			(2)	MCA
FCU-1	JUDY'S STUDIO	VERTICAL	400	0.20	(1)	N/A	--	--	(2)	(2)	(2)	MITSUBISHI NTXAMT12A12A	(3)	HP-2
FCU-2	GYM	VERTICAL	400	0.20	(1)	N/A	--	--	(2)	(2)	(2)	MITSUBISHI NTXAMT12A12A	(3)	HP-2
FCU-3	PLA YROOM	VERTICAL	400	0.20	(1)	N/A	--	--	(2)	(2)	(2)	MITSUBISHI NTXAMT12A12A	(3)	HP-2
FCU-4	KITCHEN/LIVING/DINING ROOMS	VERTICAL	900	0.50	(1)	N/A	--	--	(2)	(2)	(2)	MITSUBISHI NTXAMT36A12A	(3)	HP-1
FCU-5	PRIMARY BEDROOM	HORIZONTAL	570	0.20	(1)	N/A	--	--	(2)	(2)	(2)	MITSUBISHI NTKDKS18A112A	(3)	HP-1
FCU-6	MEDIA/FAMILY ROOM	VERTICAL	400	0.20	(1)	N/A	--	--	(2)	(2)	(2)	MITSUBISHI NTXAMT12A12A	(3)	HP-2
FCU-7	ENTRY	VERTICAL	400	0.20	(1)	N/A	--	--	(2)	(2)	(2)	MITSUBISHI NTXAMT12A12A	(3)	HP-2
FCU-8	GUEST SUITE	VERTICAL	400	0.20	(1)	N/A	--	--	(2)	(2)	(2)	MITSUBISHI NTXAMT12A12A	(3)	HP-3
FCU-9	BONUS/PLA YROOM	VERTICAL	400	0.20	(1)	N/A	--	--	(2)	(2)	(2)	MITSUBISHI NTXAMT12A12A	(3)	HP-3
FCU-10	OFFICE	VERTICAL	400	0.20	(1)	N/A	--	--	(2)	(2)	(2)	MITSUBISHI NTXAMT12A12A	(3)	HP-3
FCU-11	GUEST BEDROOM	VERTICAL	400	0.20	(1)	N/A	--	--	(2)	(2)	(2)	MITSUBISHI NTXAMT12A12A	(3)	HP-3
FCU-12	KIDS BEDROOM	VERTICAL	400	0.20	(1)	N/A	--	--	(2)	(2)	(2)	MITSUBISHI NTXAMT12A12A	(3)	HP-3

- NOTES: (1) OUTDOOR AIR PROVIDED VIA WHOLE HOUSE VENTILATION SYSTEM.
(2) INDOOR UNIT POWERED FROM OUTDOOR UNIT.
(3) PROVIDE MANUFACTURER'S OPTIONAL CONDENSATE PUMP.

EQUIP. NO.	SERVICE	CAPACITY, TONS	SPLIT SYSTEM HEAT PUMP SCHEDULE – OUTDOOR UNIT										
			TOTAL COOLING CAPACITY, BTUH		SEER	TOTAL HEATING CAPACITY, BTUH		HSPF	ELECTRICAL		WEIGHT, LBS	BASIS OF DESIGN (1)(2)(3)(4)	CONNECTED BRANCH BOX
			CFM	BTUH	ESR	ESR	ESR	VOLTAGE	MCA	MCOCP			
HP-1	PER PLANS	5.0	60,000	60,000	17.8	66,000	10.7	230V/1P	46.0	60	310	MITSUBISHI NTKMSM60A182AA	BC-1
HP-2	PER PLANS	5.0	60,000	60,000	17.8	66,000	10.7	230V/1P	46.0	60	310	MITSUBISHI NTKMSM60A182AA	BC-2
HP-3	PER PLANS	5.0	60,000	60,000	17.8	66,000	10.7	230V/1P	46.0	60	310	MITSUBISHI NTKMSM60A182AA	BC-3

- NOTES: (1) ARI LISTED WITH ALL STANDARD FEATURES, INSTALLATION ACCESSORIES AND COMPRESSOR SHORT CYCLING PROTECTION, FILTER DRIVER, REFRIGERANT LINE FLUID, LIQUID SOLENOID VALVE AND SAFETY PRESSURE SWITCHES. INSTALL REFRIGERANT TUBING AND LENGTH IN STRICT ACCORDANCE WITH MANUFACTURER'S RECOMMENDATION.
(2) PROVIDE ALL REQUIRED ACCESSORIES FOR LOW-AMBIENT AND LONG-LINE APPLICATIONS.
(3) ROUTING OF REFRIGERANT LINES FROM INDOOR UNITS TO OUTDOOR UNITS NOT SHOWN ON PLANS. CONTRACTOR TO FIELD COORDINATE ROUTING.
(4) REFRIGERANT SHALL BE R-410A.

EQUIP. NO.	SERVICE	NUMBER OF PORTS	BRANCH BOX CONTROLLER SCHEDULE							
			ELECTRICAL			WEIGHT, LBS.	BASIS OF DESIGN (1)(2)	NUMBER OF CONNECTED INDOOR UNITS	CONNECTED INDOOR FAN COIL UNITS	CONNECTED OUTDOOR HEAT PUMP UNIT
			VOLTAGE	MCA	MCOCP					
BC-1	PER PLANS	2	(3)	(3)	(3)	22	TAC-MKA31BC	2	FCU-4,5	HP-1
BC-2	PER PLANS	5	(3)	(3)	(3)	25	TAC-MKA51BC	5	FCU-1,2,3,6,7	HP-2
BC-3	PER PLANS	5	(3)	(3)	(3)	25	TAC-MKA51BC	5	FCU-8,9,10,11,12	HP-3

- NOTES:(1) INSTALL IN ACCORDANCE WITH MANUFACTURER'S INSTALLATION REQUIREMENTS.
(2) CONTRACTOR TO FIELD COORDINATE ROUTING OF REFRIGERANT PIPING, REFRIGERANT PIPE
(3) BRANCH BOX CONTROLLER POWERED FROM OUTDOOR HEAT PUMP UNIT.

EQUIP. NO.	SERVICE	TYPE	FAN SCHEDULE							
			FAN		ELECTRICAL		OPERATION	BASIS OF DESIGN (1)		
			AIRFLOW, CFM	ESP. IN WG	VOLTAGE	HP				
EF-1	BATHROOM/POWDER ROOM	CEILING MOUNTED	50	0.25	120V/1P	FHP	(2)	PANASONIC FV-0511VK2	(3)(4)(5)	
EF-2	KILN ROOM	CEILING MOUNTED	100	0.25	120V/1P	FHP	(6)	PANASONIC FV-0511VK2	(4)	
EF-3	STORAGE ROOM	CEILING MOUNTED	250	0.25	120V/1P	FHP	(7)	PANASONIC FV-30V03		
EF-4	POOL/SPA MECH ROOM	CEILING MOUNTED	200	0.25	120V/1P	FHP	CONTINUOUS	PANASONIC FV-30V03		
EF-5	GYM	CEILING MOUNTED	100	0.25	120V/1P	FHP	(2)	PANASONIC FV-0511VK2	(3)(4)(5)	
EF-6	LAUNDRY ROOM	CEILING MOUNTED	50	0.25	120V/1P	FHP	(2)	PANASONIC FV-0511VK2	(3)(4)(5)	
EF-7	MUD ROOM 103	CEILING MOUNTED	50	0.25	120V/1P	FHP	(2)	PANASONIC FV-0511VK2	(3)(4)(5)	
EF-8	MUD ROOM 113	CEILING MOUNTED	50	0.25	120V/1P	FHP	(2)	PANASONIC FV-0511VK2	(3)(4)(5)	
EF-9	MUD ROOM 206	CEILING MOUNTED	50	0.25	120V/1P	FHP	(2)	PANASONIC FV-0511VK2	(3)(4)(5)	
EF-10	CRAWL SPACE	CEILING MOUNTED	50	0.25	120V/1P	FHP	CONTINUOUS	PANASONIC FV-0511VK2		

- NOTES: (1) PROVIDE BACKDRAFT DAMPERS ON EXHAUST FANS.
(2) FAN SHALL RUN VIA MOTION SENSOR.
(3) 1.0 SONES MAXIMUM.
(4) FAN SHALL BE ENERGY STAR RATED.
(5) PROVIDE MANUFACTURER'S OPTIONAL MOTION SENSOR.
(6) FAN SHALL BE INTERLOCKED WITH WALL THERMOSTAT. FAN SHALL TURN ON WHEN ROOM TEMPERATURE REACHES 70° F.
(7) FAN SHALL BE INTERLOCKED WITH WALL THERMOSTAT. FAN SHALL TURN ON WHEN ROOM TEMPERATURE REACHES 90° F.

EQUIP. NO.	SERVICE	MOUNTING/DISCHARGE	ENERGY RECOVERY VENTILATOR							
			FAN		ELECTRICAL		SENSIBLE HEAT RECOVERY EFFICIENCY	BASIS OF DESIGN (1)(2)(3)		
			AIRFLOW, CFM	ESP. IN WG	VOLTAGE	WATTS			MCOCP	
DDAS-1	PER PLANS	VERTICAL	120	0.4	120V/1P	45	15	0.77	PANASONIC FV-20VEC1	

- NOTES: (1) INSTALL IN ACCORDANCE WITH MANUFACTURER'S INSTALLATION REQUIREMENTS.
(2) UNIT SHALL RUN CONTINUOUSLY.
(3) UNIT SHALL HAVE A MINIMUM MERV 8 FILTER.

EQUIP. NO.	BASIS OF DESIGN	FAN EFFICACY TABLE				
		AIRFLOW, CFM	ELECTRICAL, WATTS	MINIMUM FAN EFFICACY (1)	FAN EFFICACY	
EF-1	PANASONIC FV-0511VK2	50	6.2	1.4 CFM/WATT	8.3 CFM/WATT	
EF-2	PANASONIC FV-0511VK2	100	13.1	1.4 CFM/WATT	7.7 CFM/WATT	
EF-3	PANASONIC FV-30V03	250	66.8	2.8 CFM/WATT	4.1 CFM/WATT	
EF-4	PANASONIC FV-30V03	200	60.0	2.8 CFM/WATT	3.3 CFM/WATT	
EF-5	PANASONIC FV-0511VK2	100	13.1	1.4 CFM/WATT	7.7 CFM/WATT	
EF-6	PANASONIC FV-0511VK2	50	6.2	1.4 CFM/WATT	8.3 CFM/WATT	
EF-7	PANASONIC FV-0511VK2	50	6.2	1.4 CFM/WATT	8.3 CFM/WATT	
EF-8	PANASONIC FV-0511VK2	50	6.2	1.4 CFM/WATT	8.3 CFM/WATT	
EF-9	PANASONIC FV-0511VK2	50	6.2	1.4 CFM/WATT	8.3 CFM/WATT	
EF-10	PANASONIC FV-0511VK2	50	6.2	1.4 CFM/WATT	8.3 CFM/WATT	
DDAS-1	PANASONIC FV-20VECT	120	45	1.2 CFM/WATT	2.6 CFM/WATT	

- NOTES: (1) PER 2018 WSEC TABLE R403.6.1.

CALLOUT	DESCRIPTION	AIRFLOW RANGE, CFM	FACE SIZE, IN	BASIS OF DESIGN
CD-1	CEILING DIFFUSER	0-100	8x8	SHOEMAKER 100 O SERIES
CD-2	CEILING DIFFUSER	0-200	12x12	SHOEMAKER 100 O SERIES
CD-3	CEILING DIFFUSER	0-50	6x6	SHOEMAKER 100 O SERIES
CG-1	CEILING GRILLE	0-125	8ø	SHOEMAKER 90 SERIES
CG-2	CEILING GRILLE	0-250	12ø	SHOEMAKER 90 SERIES
CG-3	CEILING GRILLE	0-325	14ø	SHOEMAKER 90 SERIES
EG-1	EXHAUST GRILLE	0-100	8x8	SHOEMAKER 1050 SERIES
FG-1	FLOOR GRILLE	0-100	10x4	SHOEMAKER 375 SERIES
FG-2	FLOOR GRILLE	0-150	10x6	SHOEMAKER 375 SERIES
FG-3	FLOOR GRILLE	0-200	14x6	SHOEMAKER 375 SERIES
FG-4	FLOOR GRILLE	0-250	16x6	SHOEMAKER 375 SERIES
RG-1	RETURN GRILLE	0-100	8x8	SHOEMAKER 1050 SERIES
RG-2	RETURN GRILLE	0-2000	20x20	SHOEMAKER 1050 SERIES
RG-3	RETURN GRILLE	0-750	14x14	SHOEMAKER 1050 SERIES
RG-4	RETURN GRILLE	0-200	10x10	SHOEMAKER 1050 SERIES
RG-5	RETURN GRILLE	0-650	18x12	SHOEMAKER 1050 SERIES
RG-6	RETURN GRILLE	0-325	14x8	SHOEMAKER 1050 SERIES
RG-7	RETURN GRILLE	0-425	18x8	SHOEMAKER 1050 SERIES
RG-8	RETURN GRILLE	0-570	14x14	SHOEMAKER 1050 SERIES
RG-9	RETURN GRILLE	0-600	14ø	SHOEMAKER 90 SERIES
SG-1	SUPPLY GRILLE	0-250	16x6	SHOEMAKER 950 SERIES
SG-2	SUPPLY GRILLE	0-425	20x8	SHOEMAKER 950 SERIES
SG-3	SUPPLY GRILLE	0-75	12x6	SHOEMAKER 950 SERIES
SG-4	SUPPLY GRILLE	0-375	18x8	SHOEMAKER 950 SERIES
SG-5	SUPPLY GRILLE	0-570	14x14	SHOEMAKER 950 SERIES

DUCT INSULATION SCHEDULE			
DUCT TYPE	INSULATION MATERIAL	R-VALUE	VAPOR RETARDER REQUIRED?
DUCTS LOCATED OUTSIDE THE BUILDING ENVELOPE	MINERAL-WOOL BLANKET	8.0	Y

NOTES

WHOLE HOUSE VENTILATION REQUIREMENTS
EACH DWELLING UNIT OR SLEEPING UNIT SHALL BE EQUIPPED WITH A WHOLE-HOUSE MECHANICAL VENTILATION SYSTEM THAT COMPLIES WITH SECTIONS M1505.4.1 THROUGH M1505.4.4.

BATHROOMS, TOILET ROOMS, AND KITCHENS SHALL INCLUDE A LOCAL EXHAUST SYSTEM. SUCH LOCAL EXHAUST SYSTEMS SHALL HAVE THE CAPACITY TO EXHAUST THE MINIMUM AIRFLOW RATE IN ACCORDANCE WITH TABLE M1505.4.4(1). FANS REQUIRED BY THIS SECTION SHALL BE PROVIDED WITH CONTROLS THAT ENABLE MANUAL OVERRIDE OR AUTOMATIC OCCUPANCY SENSOR, HUMIDITY SENSOR OR POLLUTANT SENSOR CONTROLS. AN "ON/OFF" SWITCH SHALL MEET THIS REQUIREMENT FOR MANUAL CONTROLS. MANUAL FAN CONTROLS SHALL BE READILY ACCESSIBLE IN THE ROOM SERVED BY THE FAN.

2018 IRC TABLE M1505.4.4(1)		
AREA TO BE EXHAUSTED	INTERMITTENT	CONTINUOUS
KITCHENS	100 CFM	30 CFM
BATHROOMS-TOILET ROOMS	50 CFM	20 CFM

THE WHOLE HOUSE VENTILATION SYSTEM SHALL CONSIST OF AN ERV/HRV WITH INTEGRAL FANS; AND THE ASSOCIATED DUCTS AND CONTROLS. THE SYSTEM SHALL BE DESIGNED AND INSTALLED TO SUPPLY AND EXHAUST THE MINIMUM OUTDOOR AIRFLOW RATES PER SECTION M1505.4.3 AS CORRECTED BY THE BALANCED AND/OR DISTRIBUTED WHOLE-HOUSE VENTILATION SYSTEM COEFFICIENTS IN ACCORDANCE WITH SECTION M1505.4.3.1.

UNIT TYPE	TOTAL SQUARE FOOTAGE	NUMBER OF BEDROOMS	2018 IRC CRITERIA 1)(2)					TOTAL CFM PROVIDED BY ERV/HRV
			NUMBER OF BEDROOMS	FLOOR AREA (SQUARE FEET)	REQUIRED CFM	VENTILATION QUALITY ADJUSTMENT COEFFICIENT (3)	MINIMUM VENTILATION RATE REQUIRED	
HOUSE	6,440	4	4	6,440	94	1.0	102	120

- NOTE:(1) VENTILATION CRITERIA IS PER THE 2018 IRC, CHAPTER 15, EQUATION 15-1.
(2) MINIMUM OSA FOR CONTINUOUSLY OPERATING FAN(S)
(3) ADJUSTMENT COEFFICIENT IS PER 2018 IRC, TABLE M1505.4.3(2) FOR A BALANCED AND DISTRIBUTED WHOLE HOUSE VENTILATION SYSTEM.

2018 IRC TABLE M1505.4.3(2)		
SYSTEM TYPE	DISTRIBUTED	NOT DISTRIBUTED
BALANCED	1.0	1.25
NOT BALANCED	1.25	1.5

THE BALANCED WHOLE HOUSE VENTILATION SYSTEM SHALL INCLUDE BOTH SUPPLY AND EXHAUST FANS. THE SUPPLY AND EXHAUST FANS SHALL HAVE AIRFLOW THAT IS WITHIN 10 PERCENT OF EACH OTHER. THE TESTED AND BALANCED TOTAL MECHANICAL EXHAUST AIRFLOW RATE IS WITHIN 10 PERCENT OR 5 CFM, WHICHEVER IS GREATER, OF THE TOTAL MECHANICAL SUPPLY AIRFLOW RATE. THE FLOW RATE TEST RESULTS SHALL BE SUBMITTED AND POSTED IN ACCORDANCE WITH SECTION M1505.4.1.7. THE EXHAUST FAN SHALL MEET THE REQUIREMENTS OF SECTION M1505.4.1.2. THE SUPPLY FAN SHALL MEET THE REQUIREMENTS OF SECTION M1505.4.1.3. BALANCED VENTILATION SYSTEMS WITH BOTH SUPPLY AND EXHAUST FANS IN A PACKAGED PRODUCT, SUCH AS AN ERV/HRV, SHALL MEET THE REQUIREMENTS OF HWI 9.0, AS APPLICABLE. INTERMITTENT DRYER EXHAUST, INTERMITTENT RANGE HOOD EXHAUST, AND INTERMITTENT TOILET ROOM EXHAUST AIRFLOW RATES ABOVE THE RESIDENTIAL DWELLING OR SLEEPING UNIT MINIMUM VENTILATION RATE ARE EXEMPT FROM THE BALANCED AIRFLOW CALCULATIONS.

WHOLE HOUSE MECHANICAL VENTILATION SYSTEMS SHALL BE TESTED, BALANCED AND VERIFIED TO PROVIDE A FLOW RATE NOT LESS THAN THE MINIMUM REQUIRED BY SECTIONS M1505.4.3 AND M1505.4.4. TESTING SHALL BE PERFORMED ACCORDING TO THE VENTILATION EQUIPMENT MANUFACTURER'S INSTRUCTIONS, OR BY USING A FLOW HOOD, FLOW GRID, OR OTHER AIRFLOW MEASURING DEVICE AT THE MECHANICAL VENTILATION FAN'S INLET TERMINALS, OUTLET TERMINALS OR GRILLES OR IN THE CONNECTED VENTILATION DUCTS, WHERE REQUIRED BY THE BUILDING OFFICIAL. TESTING SHALL BE CONDUCTED BY AN APPROVED THIRD PARTY. A WRITTEN REPORT OF THE RESULTS OF THE TEST SHALL BE SIGNED BY THE PARTY CONDUCTING THE TEST AND PROVIDED TO THE BUILDING OFFICIAL AND BE POSTED IN THE DWELLING UNIT PER SECTION M1505.4.1.7.

WHOLE HOUSE VENTILATION SUPPLY AND EXHAUST FANS SPECIFIED IN THIS SECTION SHALL HAVE A MINIMUM EFFICACY AS PRESCRIBED IN THE WASHINGTON STATE ENERGY CODE. DESIGN AND INSTALLATION OF THE SYSTEM OR EQUIPMENT SHALL BE CARRIED OUT IN ACCORDANCE WITH MANUFACTURER'S INSTALLATION INSTRUCTIONS. WHOLE HOUSE VENTILATION FANS SHALL BE RATED FOR SOUND AT NO LESS THAN THE MINIMUM AIRFLOW RATE REQUIRED BY SECTION M1505.4.3.1. VENTILATION FANS SHALL BE RATED FOR SOUND AT A MINIMUM OF 1.0 SONE. THIS SOUND RATING SHALL BE AT A MINIMUM OF 0.1 IN. W.C. (25 PA) STATIC PRESSURE IN ACCORDANCE WITH HWI PROCEDURES SPECIFIED IN SECTION M1505.4.1.2 AND M1505.4.1.3. EXCEPTION: HVAC AIR HANDLERS, ERV/HRV UNITS, AND REMOTE MOUNTED FANS NEED NOT MEET THE SOUND REQUIREMENTS. TO BE CONSIDERED FOR THIS EXCEPTION, A REMOTE MOUNTED FAN MUST BE MOUNTED OUTSIDE THE HABITABLE SPACES, BATHROOMS, TOILETS, AND HALLWAYS, AND THERE MUST BE AT LEAST 4 FEET OF DUCTWORK BETWEEN THE FAN AND THE INTAKE GRILLE.

- CONTROLS FOR THE WHOLE-HOUSE VENTILATION SYSTEM SHALL COMPLY WITH THE FOLLOWING:
1. THE WHOLE-HOUSE VENTILATION SYSTEM SHALL BE CONTROLLED WITH MANUAL SWITCHES, TIMERS OR OTHER MEANS THAT PROVIDE FOR AUTOMATIC OPERATION OF THE VENTILATION SYSTEM THAT HAVE READY ACCESS FOR THE OCCUPANT.
2. THE WHOLE-HOUSE MECHANICAL VENTILATION SYSTEM SHALL BE PROVIDED WITH CONTROLS THAT ENABLE MANUAL OVERRIDE OFF OF THE SYSTEM BY THE OCCUPANT DURING PERIODS OF POOR OUTDOOR AIR QUALITY. CONTROLS SHALL INCLUDE PERMANENT TEXT OR A SYMBOL INDICATING THEIR FUNCTION. RECOMMENDED CONTROL PERMANENT LABELING TO INCLUDE TEXT SIMILAR TO THE FOLLOWING: "LEAVE ON UNLESS OUTDOOR AIR QUALITY IS VERY POOR." MANUAL CONTROLS SHALL HAVE READY ACCESS FOR THE OCCUPANT.
3. WHOLE-HOUSE VENTILATION SYSTEMS SHALL BE CONFIGURED TO OPERATE CONTINUOUSLY EXCEPT WHERE INTERMITTENT OFF CONTROLS ARE PROVIDED IN ACCORDANCE WITH SECTION M1505.4.3.2.

FACTORY-BUILT INTAKE/EXHAUST COMBINATION TERMINATIONS
PER 2018 IMC 401.4.3, ITEM 3, EXCEPTION, SEPARATION IS NOT REQUIRED BETWEEN INTAKE AIR OPENINGS AND LIVING SPACE RELIEF AIR EXHAUST AIR OPENINGS OF AN INDIVIDUAL DWELLING UNIT OR SLEEPING UNIT, NOT TO INCLUDE COMMON AREAS OUTSIDE OF THE DWELLING OR SLEEPING UNIT, WHERE A FACTORY-BUILT INTAKE/EXHAUST COMBINATION TERMINATION FITTING, LISTED AND INSTALLED IN ACCORDANCE WITH THE MANUFACTURER'S INSTRUCTIONS, IS USED TO SEPARATE THE AIR STREAMS. A MINIMUM OF 5 FEET HORIZONTAL SEPARATION BETWEEN OTHER ENVIRONMENTAL AIR EXHAUST OUTLETS AND OTHER DWELLING OR SLEEPING UNIT FACTORY-BUILT INTAKE/EXHAUST COMBINATION TERMINATIONS SHALL BE MAINTAINED.

ENERGY CODE NOTES

WSEC SECTION R406: ADDITIONAL ENERGY EFFICIENCY REQUIREMENTS

- EACH DWELLING UNIT IN A RESIDENTIAL BUILDING SHALL COMPLY WITH SUFFICIENT CREDIT OPTIONS FROM SECTION R406. CREDIT FROM BOTH SECTIONS R406.2 AND R406.3 ARE REQUIRED:
- #1. SMALL DWELLING UNIT: 3.0 CREDITS
DWELLING UNITS LESS THAN 1500 SQUARE FEET IN CONDITIONED FLOOR AREA WITH LESS THAN 300 SQUARE FEET OF FENESTRATION AREA. ADDITIONS TO EXISTING BUILDING THAT ARE GREATER THAN 500 SQUARE FEET OF HEATED FLOOR AREA BUT LESS THAN 1500 SQUARE FEET.
 - #2. MEDIUM DWELLING UNIT: 6.0 CREDITS
ALL DWELLING UNITS THAT ARE NOT INCLUDED IN #1, #3 OR #4.
 - #3. LARGE DWELLING UNIT: 7.0 CREDITS
DWELLING UNITS EXCEEDING 5000 SQUARE FEET OF CONDITIONED FLOOR AREA.
 - #4. DWELLING UNITS SERVING R-2 OCCUPANCIES: 4.5 CREDITS
 - #5. ADDITIONS LESS THAN 500 SQUARE FEET: 1.5 CREDITS

TABLE R406.2 FUEL NORMALIZATION CREDITS					
SYSTEM TYPE	DESCRIPTION	CREDITS	CREDIT TAKEN		
1	COMBUSTION HEATING EQUIPMENT MEETING MINIMUM FEDERAL EFFICIENCY STANDARDS FOR THE EQUIPMENT LISTED IN TABLE C403.3.2(4) OR C403.3.2(5)	0.0	--		
2	FOR AN INITIAL HEATING SYSTEM USING A HEAT PUMP THAT MEETS FEDERAL STANDARDS FOR EQUIPMENT LISTED IN TABLE C403.3.2(2)(c) OR C403.3.2(2) OR AIR TO WATER HEAT PUMP UNITS THAT ARE CONFIGURED TO PROVIDE BOTH HEATING AND COOLING AND ARE RATED IN ACCORDANCE WITH AHRI 550 / 590	1.0	1.0		
3	FOR HEATING SYSTEM BASED ON ELECTRIC RESISTANCE ONLY (EITHER FORCED AIR OR ZONAL)	-1.0			

- FLAG NOTES:**
- 1 KILN (REF). SKUTT KM-1027.
 - 2 DUCTING FOR KILN SHALL BE SIZED PER MANUFACTURER'S INSTALLATION INSTRUCTIONS.
 - 3 SKUTT OPTIONAL VENT KIT (REF). SKUTT ENVIROVENT 2.
 - 4 BOTTOM OF RETURN GRILLE SHALL BE 2" AFF.
 - 5 VENT HOOD (TYP OF 5). EXHAUST AIR VENT HOOD TERMINATIONS SHALL BE A MINIMUM OF 3 FEET ABOVE THE OUTSIDE AIR INTAKE VENT HOODS.

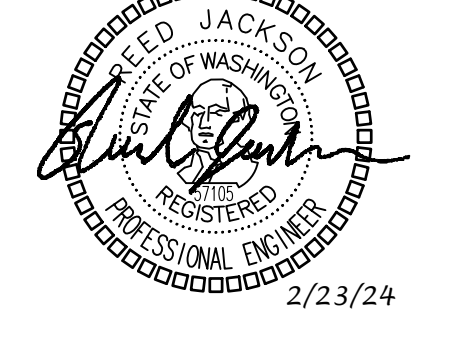

CRAWL SPACE SQUARE FOOTAGE: 468
PER R408.3, MINIMUM OF 1 CFM PER 50
SQUARE FEET OF CRAWL SPACE FLOOR
ARE FOR CONTINUOUSLY OPERATED
MECHANICAL EXHAUST.
MINIMUM REQUIRED: 9.36 CFM
EXHAUST PROVIDED: 50 CFM

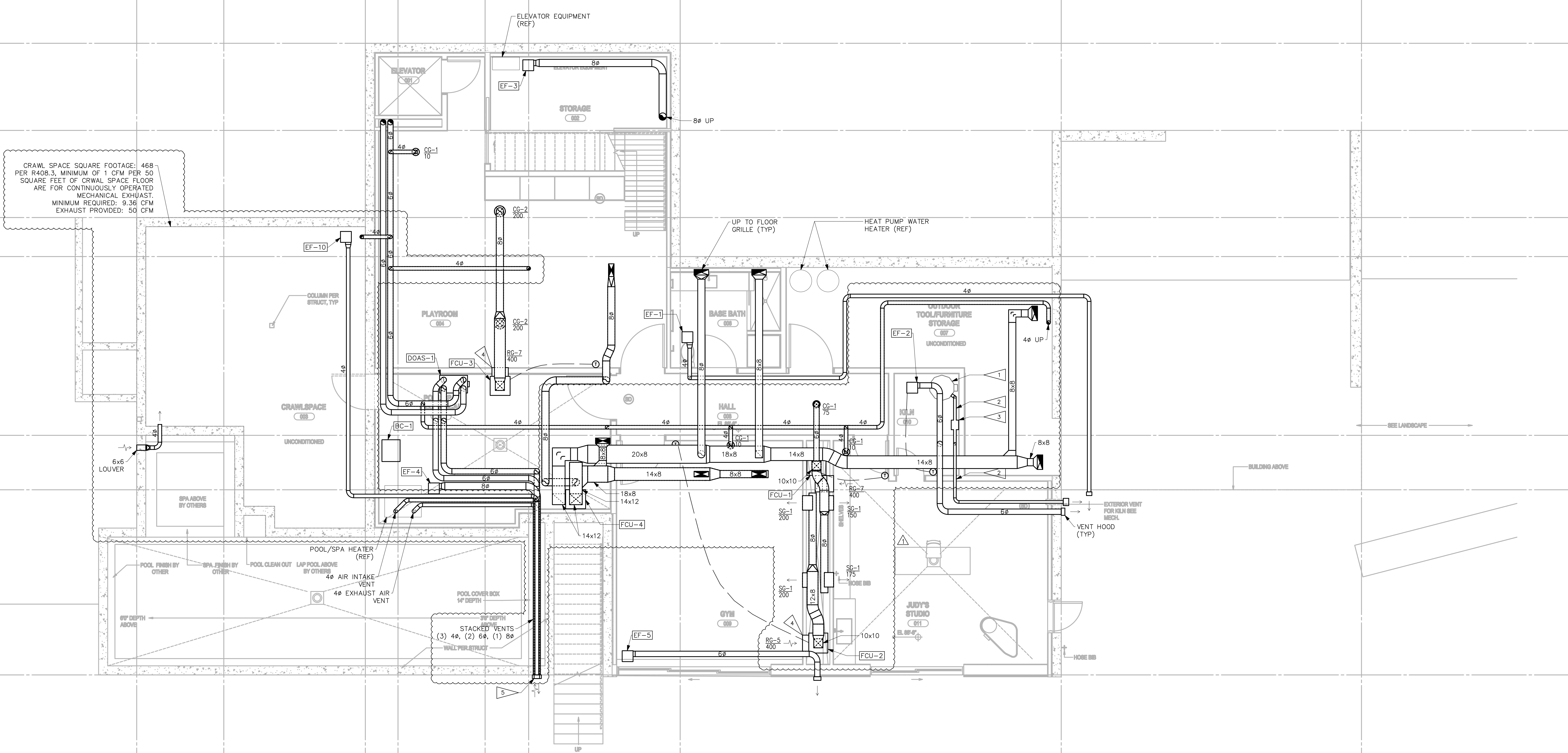

LOWER LEVEL FLOOR PLAN
SCALE: 1/4" = 1'-0"

project architect: JMN
project manager: JMN
drawn by: JMN
checked by: PR
job no.: 1216-001

revisions:
1 2/23/24 PERMIT REVISION SET

no.: date: description:

NOT FOR CONSTRUCTION
PERMIT SET

2/23/2024



title:

LOWER LEVEL FLOOR PLAN

sheet:

M2.10

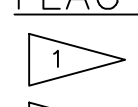
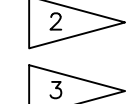
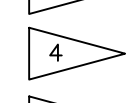
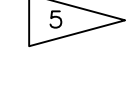
DATE PLOTTED: 2/23/24 10:00 AM
PROJECT: FUSED ELEMENTS RESIDENCE (204)E/2024 FLOOR PLANS: 00-00-2024 14.37

- FLAG NOTES:
-  POC RANGE HOOD.
 -  FIREPLACE VENT. CONFIRM SIZE WITH MFR.
 -  VENTLESS HEAT PUMP DRYER.
 -  ACCESS PANEL.
 -  BOTTOM OF RETURN GRILLE SHALL BE 2" AFF.

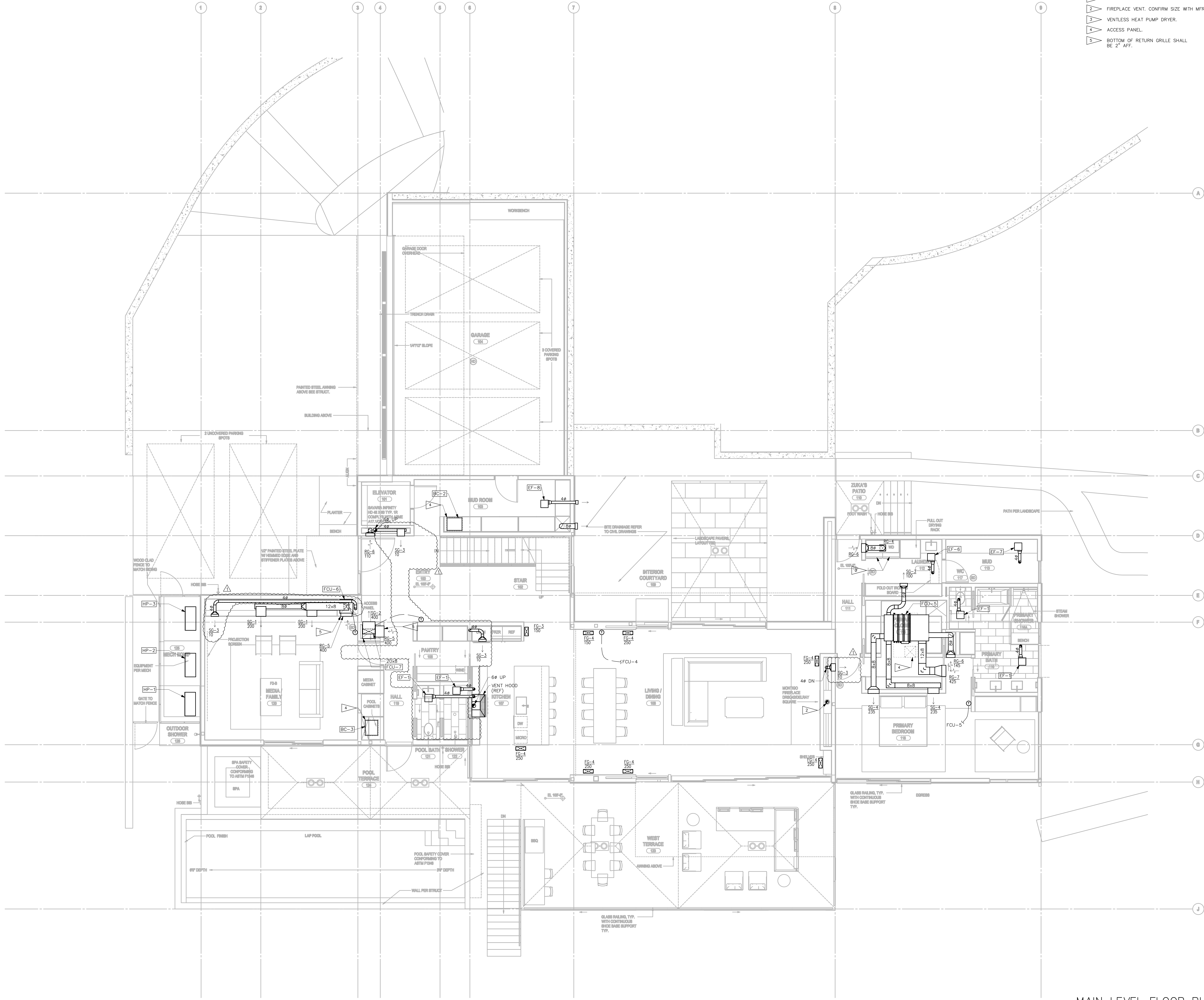

155 South Jackson St. Suite 100
Seattle, Washington 98104 USA
P: 206.441.4477
www.olsonkundig.com

Olson Kundig

Project: FUSED ELEMENTS
4525 FOREST AVE SE MERCER ISLAND WA 98040

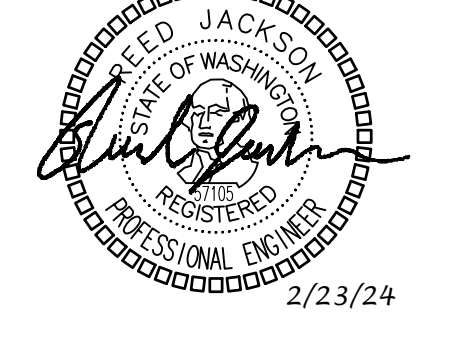

project architect: JMN
project manager: JMN
drawn by: JMN
checked by: PR
job no.: 1216-001

revisions:
1 2/23/24 PERMIT REVISION SET

no.: date: description:
NOT FOR CONSTRUCTION
PERMIT SET

2/23/2024

title:
MAIN LEVEL FLOOR PLAN

sheet:
M2.20

MAIN LEVEL FLOOR PLAN
SCALE: 1/4" = 1'-0"

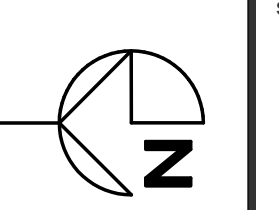

DATE PLOTTED: 2/23/2024 10:00:00 AM
PROJECT: FUSED ELEMENTS RESIDENCE (04/26/2024) P2_20 FLOOR PLAN DWG: 04-08-2024 14:37

FLAG NOTES:
 FIREPLACE VENT. CONFIRM SIZE WITH MFR.
 VENTLESS HEAT PUMP DRYER.
 BOTTOM OF RETURN GRILLE SHALL BE 2" AFF.

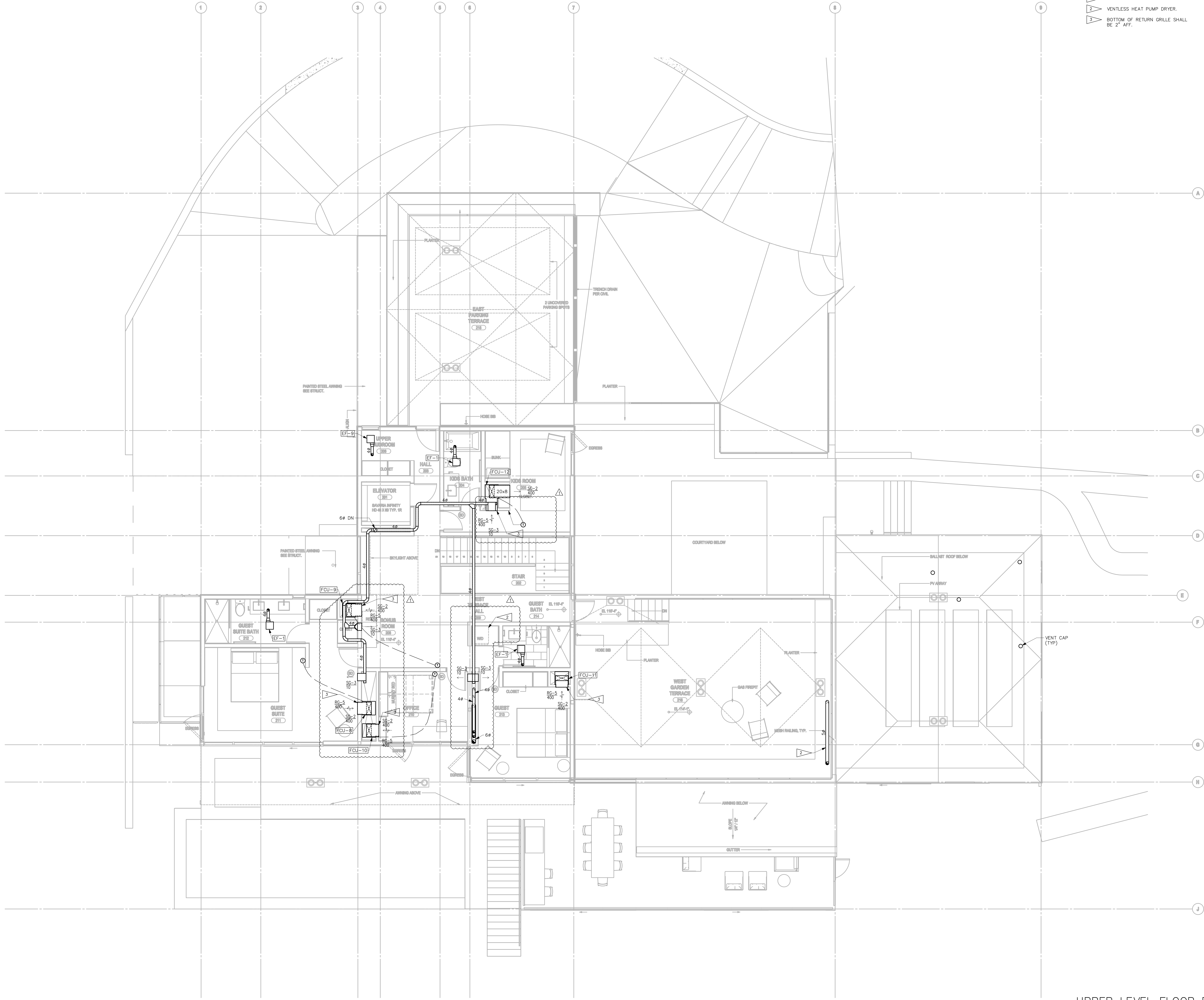

Olson Kundig
 project: FUSED ELEMENTS
 4525 FOREST AVE SE MERCER ISLAND WA 98040

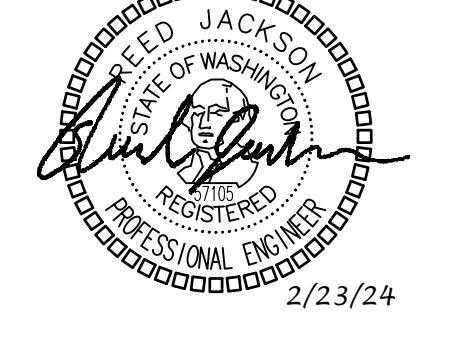
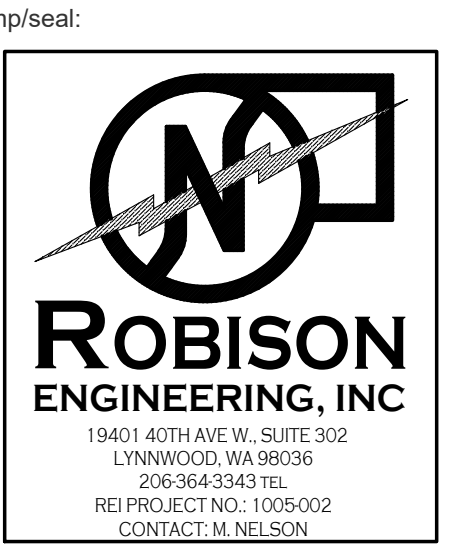

project architect: JMN
 project manager: JMN
 drawn by: JMN
 checked by: PR
 job no.: 1216-001

revisions:
 1 2/23/24 PERMIT REVISION SET

NOT FOR CONSTRUCTION
 PERMIT SET

2/23/2024

UPPER LEVEL FLOOR PLAN

sheet: M2.30

UPPER LEVEL FLOOR PLAN
 SCALE: 1/4" = 1'-0"

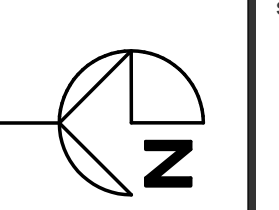

UPPER LEVEL FLOOR PLAN (M2.30) - FUSED ELEMENTS RESIDENCE (04/26/2024) - 04/26/2024 14:37

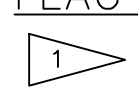
FLAG NOTES:
 FIREPLACE VENT. CONFIRM SIZE WITH MFR.

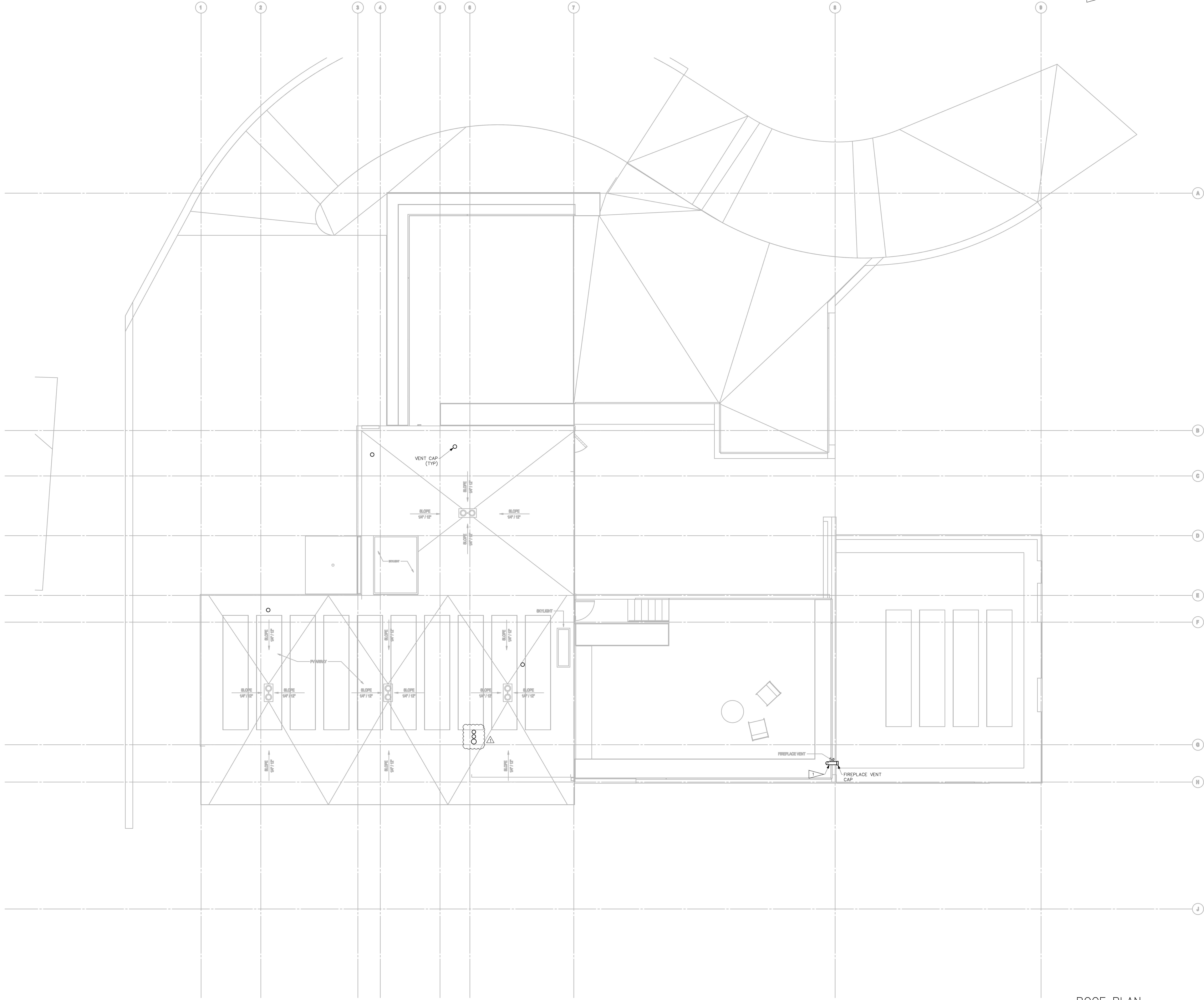

155 South Jackson St. Suite 100
 Seattle, Washington 98104 USA
 P: 206.465.4477
 F: 206.465.4478
 www.olsonkundig.com

Olson Kundig

project:
FUSED ELEMENTS
 4525 FOREST AVE SE MERCER ISLAND WA 98040

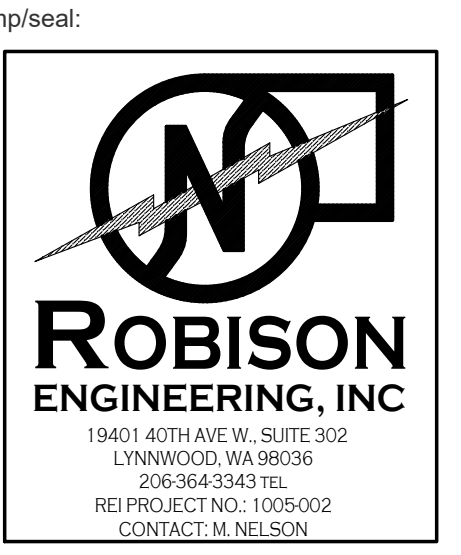

2/23/24

project architect: JMN
 project manager: JMN
 drawn by: JMN
 checked by: PR
 job no.: 1216-001

revisions:
 1 2/23/24 PERMIT REVISION SET

no.: date: description:
 NOT FOR CONSTRUCTION
 PERMIT SET

2/23/2024

title:
ROOF PLAN

sheet:
M2.40

ROOF PLAN
 SCALE: 1/4" = 1'-0"

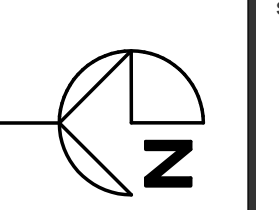

EQUIPMENT DATA SHEETS

HEAT PUMP WATER HEATER NEEA RATING

Product Line	Model	Capacity	Input Power	Output Power	SEER	SEER2	SEER3	SEER4	SEER5	SEER6	SEER7	SEER8	SEER9	SEER10	SEER11	SEER12	SEER13	SEER14	SEER15	SEER16	SEER17	SEER18	SEER19	SEER20	SEER21	SEER22	SEER23	SEER24	SEER25	SEER26	SEER27	SEER28	SEER29	SEER30	SEER31	SEER32	SEER33	SEER34	SEER35	SEER36	SEER37	SEER38	SEER39	SEER40	SEER41	SEER42	SEER43	SEER44	SEER45	SEER46	SEER47	SEER48	SEER49	SEER50																																																																																																																																																																																																																																																																																																																																																																																																																																																																																																																																																																																																																																																																																																																																																																																																																																																																																																																																																																																																																																																																																																																																																																																																																									
Residential Unitary Water Heaters	AP2000	30	2.0	3.0	1.1	1.3	1.5	1.7	1.9	2.1	2.3	2.5	2.7	2.9	3.1	3.3	3.5	3.7	3.9	4.1	4.3	4.5	4.7	4.9	5.1	5.3	5.5	5.7	5.9	6.1	6.3	6.5	6.7	6.9	7.1	7.3	7.5	7.7	7.9	8.1	8.3	8.5	8.7	8.9	9.1	9.3	9.5	9.7	9.9	10.1	10.3	10.5	10.7	10.9	11.1	11.3	11.5	11.7	11.9	12.1	12.3	12.5	12.7	12.9	13.1	13.3	13.5	13.7	13.9	14.1	14.3	14.5	14.7	14.9	15.1	15.3	15.5	15.7	15.9	16.1	16.3	16.5	16.7	16.9	17.1	17.3	17.5	17.7	17.9	18.1	18.3	18.5	18.7	18.9	19.1	19.3	19.5	19.7	19.9	20.1	20.3	20.5	20.7	20.9	21.1	21.3	21.5	21.7	21.9	22.1	22.3	22.5	22.7	22.9	23.1	23.3	23.5	23.7	23.9	24.1	24.3	24.5	24.7	24.9	25.1	25.3	25.5	25.7	25.9	26.1	26.3	26.5	26.7	26.9	27.1	27.3	27.5	27.7	27.9	28.1	28.3	28.5	28.7	28.9	29.1	29.3	29.5	29.7	29.9	30.1	30.3	30.5	30.7	30.9	31.1	31.3	31.5	31.7	31.9	32.1	32.3	32.5	32.7	32.9	33.1	33.3	33.5	33.7	33.9	34.1	34.3	34.5	34.7	34.9	35.1	35.3	35.5	35.7	35.9	36.1	36.3	36.5	36.7	36.9	37.1	37.3	37.5	37.7	37.9	38.1	38.3	38.5	38.7	38.9	39.1	39.3	39.5	39.7	39.9	40.1	40.3	40.5	40.7	40.9	41.1	41.3	41.5	41.7	41.9	42.1	42.3	42.5	42.7	42.9	43.1	43.3	43.5	43.7	43.9	44.1	44.3	44.5	44.7	44.9	45.1	45.3	45.5	45.7	45.9	46.1	46.3	46.5	46.7	46.9	47.1	47.3	47.5	47.7	47.9	48.1	48.3	48.5	48.7	48.9	49.1	49.3	49.5	49.7	49.9	50.1	50.3	50.5	50.7	50.9	51.1	51.3	51.5	51.7	51.9	52.1	52.3	52.5	52.7	52.9	53.1	53.3	53.5	53.7	53.9	54.1	54.3	54.5	54.7	54.9	55.1	55.3	55.5	55.7	55.9	56.1	56.3	56.5	56.7	56.9	57.1	57.3	57.5	57.7	57.9	58.1	58.3	58.5	58.7	58.9	59.1	59.3	59.5	59.7	59.9	60.1	60.3	60.5	60.7	60.9	61.1	61.3	61.5	61.7	61.9	62.1	62.3	62.5	62.7	62.9	63.1	63.3	63.5	63.7	63.9	64.1	64.3	64.5	64.7	64.9	65.1	65.3	65.5	65.7	65.9	66.1	66.3	66.5	66.7	66.9	67.1	67.3	67.5	67.7	67.9	68.1	68.3	68.5	68.7	68.9	69.1	69.3	69.5	69.7	69.9	70.1	70.3	70.5	70.7	70.9	71.1	71.3	71.5	71.7	71.9	72.1	72.3	72.5	72.7	72.9	73.1	73.3	73.5	73.7	73.9	74.1	74.3	74.5	74.7	74.9	75.1	75.3	75.5	75.7	75.9	76.1	76.3	76.5	76.7	76.9	77.1	77.3	77.5	77.7	77.9	78.1	78.3	78.5	78.7	78.9	79.1	79.3	79.5	79.7	79.9	80.1	80.3	80.5	80.7	80.9	81.1	81.3	81.5	81.7	81.9	82.1	82.3	82.5	82.7	82.9	83.1	83.3	83.5	83.7	83.9	84.1	84.3	84.5	84.7	84.9	85.1	85.3	85.5	85.7	85.9	86.1	86.3	86.5	86.7	86.9	87.1	87.3	87.5	87.7	87.9	88.1	88.3	88.5	88.7	88.9	89.1	89.3	89.5	89.7	89.9	90.1	90.3	90.5	90.7	90.9	91.1	91.3	91.5	91.7	91.9	92.1	92.3	92.5	92.7	92.9	93.1	93.3	93.5	93.7	93.9	94.1	94.3	94.5	94.7	94.9	95.1	95.3	95.5	95.7	95.9	96.1	96.3	96.5	96.7	96.9	97.1	97.3	97.5	97.7	97.9	98.1	98.3	98.5	98.7	98.9	99.1	99.3	99.5	99.7	99.9	100.1	100.3	100.5	100.7	100.9	101.1	101.3	101.5	101.7	101.9	102.1	102.3	102.5	102.7	102.9	103.1	103.3	103.5	103.7	103.9	104.1	104.3	104.5	104.7	104.9	105.1	105.3	105.5	105.7	105.9	106.1	106.3	106.5	106.7	106.9	107.1	107.3	107.5	107.7	107.9	108.1	108.3	108.5	108.7	108.9	109.1	109.3	109.5	109.7	109.9	110.1	110.3	110.5	110.7	110.9	111.1	111.3	111.5	111.7	111.9	112.1	112.3	112.5	112.7	112.9	113.1	113.3	113.5	113.7	113.9	114.1	114.3	114.5	114.7	114.9	115.1	115.3	115.5	115.7	115.9	116.1	116.3	116.5	116.7	116.9	117.1	117.3	117.5	117.7	117.9	118.1	118.3	118.5	118.7	118.9	119.1	119.3	119.5	119.7	119.9	120.1	120.3	120.5	120.7	120.9	121.1	121.3	121.5	121.7	121.9	122.1	122.3	122.5	122.7	122.9	123.1	123.3	123.5	123.7	123.9	124.1	124.3	124.5	124.7	124.9	125.1	125.3	125.5	125.7	125.9	126.1	126.3	126.5	126.7	126.9	127.1	127.3	127.5	127.7	127.9	128.1	128.3	128.5	128.7	128.9	129.1	129.3	129.5	129.7	129.9	130.1	130.3	130.5	130.7	130.9	131.1	131.3	131.5	131.7	131.9	132.1	132.3	132.5	132.7	132.9	133.1	133.3	133.5	133.7	133.9	134.1	134.3	134.5	134.7	134.9	135.1	135.3	135.5	135.7	135.9	136.1	136.3	136.5	136.7	136.9	137.1	137.3	137.5	137.7	137.9	138.1	138.3	138.5	138.7	138.9	139.1	139.3	139.5	139.7	139.9	140.1	140.3	140.5	140.7	140.9	141.1	141.3	141.5	141.7	141.9	142.1	142.3	142.5	142.7	142.9	143.1	143.3	143.5	143.7	143.9	144.1	144.3	144.5	144.7	144.9	145.1	145.3	145.5	145.7	145.9	146.1	146.3	146.5	146.7	146.9	147.1	147.3	147.5	147.7	147.9	148.1	148.3	148.5	148.7	148.9	149.1	149.3	149.5	149.7	149.9	150.1	150.3	150.5	150.7	150.9	151.1	151.3	151.5	151.7	151.9	152.1	152.3	152.5	152.7	152.9	153.1	153.3	153.5	153.7	153.9	154.1	154.3	154.5	154.7	154.9	155.1	155.3	155.5	155.7	155.9	156.1	156.3	156.5	156.7	156.9	157.1	157.3	157.5	157.7	157.9	158.1	158.3	158.5	158.7	158.9	159.1	159.3	159.5	159.7	159.9	160.1	160.3	160.5	160.7	160.9	161.1	161.3	161.5	161.7	161.9	162.1	162.3	162.5	162.7	162.9	163.1	163.3	163.5	163.7	163.9	164.1	164.3	164.5	164.7	164.9	165.1	165.3	165.5	165.7	165.9	166.1	166.3	166.5	166.7	166.9	167.1	167.3	167.5	167.7	167.9	168.1	168.3	168.5	168.7	168.9	169.1	169.3	169.5	169.7	169.9	170.1	170.3	170.5	170.7	170.9	171.1	171.3	171.5	171.7	171.9	172.1	172.3	172.5	172.7	172.9	173.1	173.3	173.5	173.7	173.9	174.1	174.3	174.5	174.7	174.9	175.1	175.3	175.5	175.7	175.9	176.1	176.3	176.5	176.7	176.9	177.1	177.3	177.5	177.7	177.9	178.1	178.3	178.5	178.7	178.9	179.1	179.3	179.5	179.7	179.9	180.1	180.3	180.5	180.7	180.9	181.1	181.3	181.5	181.7	181.9	182.1	182.3	182.5	182.7	182.9	183.1	183.3	183.5	183.7	183.9	184.1	184.3	184.5	184.7	184.9	185.1	185.3	185.5	185.7	185.9	186.1	186.3	186.5	186.7	186.9	187.1	187.3	187.5	187.7	187.9	188.1	188.3	188.5	188.7	188.9	189.1	189.3	189.5	189.7	189.9	190.1	190.3	190.5	190.7	190.9	191.1	191.3	191.5	191.7	191.9	192.1	192.3	192.5	192.7	192.9	193.1	193.3	193.5	193.7	193.9	194.1	194.3	194.5	194.7	194.9	195.1	195.3	195.5	195.7	195.9	196.1	196.3	196.5	196.7	196.9	197.1	197.3	197.5	197.7	197.9	198.1	198.3	198.5	198.7	198.9	199.1	199.3	199.5	199.7	199.9	200.1	200.3	200.5	200.7	200.9	201.1	201.3	201.5	201.7	201.9	202.1	202.3	202.5	202.7	202.9	203.1	203.3	203.5	203.7	203.9	204.1	204.3	204.5	204.7	204.9	205.1	205.3	205.5	205.7	205.9	206.1	206.3	206.5	206.7	206.9	207.1	207.3	207.5	207.7	207.9	208.1	208.3	208.5	208.7	208.9	209.1	209.3	209.5	209.7	209.9	210.1	210.3	210.5	210.7	210.9	211.1	211.3	211.5	211.7	211.9	212.1	212.3	212.5	212.7	212.9	213.1	213.3	213.5	213.7	213.9	214.1	214.3	214.5	214.7	214.9	215.1	215.3	215.5	215.7	215.9	216.1	216.3	216.5	216.7	216.9	217.1	217.3	217.5	217.7	217.9	218.1	218.3	218.5	218.7	218.9	219.1	219.3	219.5	219.7	219.9	220.1	220.3	220.5	220.7	220.9	221.1	221.3	221.5	221.7	221.9	222.1	222.3	222.5	222.7	222.9	223.1	223.3	223.5	223.7	223.9	224.1	224.3	224.5	224.7	224.9	225.1	225.3	225.5	225.7	225.9	226.1	226.3	226.5	226.7	226.9	227.1	227.3	227.5	227.7	227.9	228.1	228.3	228.5	228.7	228.9	229.1	229.3	229.5	229.7	229.9	230.1	230.3	230.5	230.7	230.9	231.1	231.3	231.5	231.7	231.9	232.1	232.3	232.5	232.7	232.9	233.1	233.3	233.5	233.7	233.9	234.1	234.3	234.5	234.7	234.9	235.1	235.3	235.5	235.7	235.9	236.1	236.3	236.5	236.7	236.9	237.1	237.3	237.5	237.7	237.9	238.1	238.3	238.5	238.7	238.9	239.1	239.3	239.5	239.7	239.9	240.1	240.3	240.5	240.7	240.9	241.1	241.3	241.5	241.7	241.9	242.1	242.3	242.5	242.7	242.9	243.1	243.3	243.5	243.7	243.9	244.1	244.3	244.5	244.7	244.9	245.1	245.3	245.5	245.7	245.9	246.1	246.3

HVAC LOAD CALCULATIONS

FUSED ELEMENTS RESIDENCE														
Supply Air Requirements														
Location	Current Supply CFM	Required Supply CFM	Peak	Cooling				Heating						
				Supply CFM	Supply CFM	Supply CFM	Supply CFM	Supply CFM	Supply CFM	Supply CFM	Supply CFM			
Base Floor Elements	0	7,146	CV - 500 of Peak	517	156,000	7,100	120	2%	207	4,477	75,500	4,500	120	1%
Room Lower Floor	0	1,310	7.45 p.m.	410	28,300	1,310	30	2%	14,100	662	30	7%		
Room Mid Floor	0	410	7.45 p.m.	126	79,100	410	40	1%	39,000	1,830	40	2%		
Room Upper Floor	0	2,230	4.00 p.m.	698	48,300	2,230	50	2%	22,700	1,070	50	1%		

FUSED ELEMENTS RESIDENCE										
Ventilation Schedule										
Location	Room Type	Ventilation Requirements	Area (ft²)	Proposed	Ventilation CFM	Supply CFM	Ventilation %			
Base Floor Elements	General	Direct	6,440	0	120	7,100	2%			
Room Lower Floor	General	Direct	1,810	3	30	1,810	2%			
Room Mid Floor	General	Direct	2,990	5	40	3,050	1%			
Room Upper Floor	General	Direct	1,620	3	30	1,620	2%			

FUSED ELEMENTS RESIDENCE															
Cooling Load Details - System															
(See "Cooling Load Details - Room" for lighting, equipment, and people loads)															
Location	Peak	Roof	Wall	Class	Vertical Partitions	Horizontal Partitions	Ventilation	Infiltration							
Base Floor Elements	July 5.00 p.m.	1,000	0%	12,000	0%	700	2%	100	1%	1,000	1%				
Room Lower Floor	July 5.00 p.m.	453	0%	16,800	5%	516	2%	0	0%	181	1%	507	4%		
Room Mid Floor	July 4.00 p.m.	2,230	0%	2,230	0%	0	0%	340	0%	317	0%	188	1%	718	1%
Room Upper Floor	July 4.00 p.m.	2,230	0%	1,670	3%	35,900	0%	0	0%	389	0%	484	1%	311	1%

FUSED ELEMENTS RESIDENCE																					
Cooling Load Details - Room																					
(See "Cooling Load Details - System" for system loads)																					
Location	Peak	Roof	Wall	Class	Vertical Partitions	Horizontal Partitions	Ventilation	Infiltration													
Base Floor Elements	CV -	1,000	0%	12,000	0%	700	2%	100	1%	1,000	1%										
Room Lower Floor	July 5.00 p.m.	915	0%	16,800	5%	516	2%	0	0%	4,900	1%	1,810	1%	484	2%						
Room Mid Floor	July 4.00 p.m.	2,300	0%	2,730	0%	0	0%	340	0%	8,150	0%	0	0%	750	1%	888	1%	718	1%		
Room Upper Floor	July 4.00 p.m.	2,240	0%	1,670	3%	35,900	0%	0	0%	6,630	0%	2,770	0%	0	0%	1,762	0%	484	1%	311	1%

See IFP/1216-001 Fused Elements Residence (Chase)/Design/Inac-load-1884

FUSED ELEMENTS RESIDENCE																
Heating Load Details - System and Room																
Location	Roof	Wall	Class	Vertical Partitions	Horizontal Partitions	Ventilation	Infiltration									
Base Floor Elements	4,476	0%	12,000	1%	36,500	5%	14,100	1%	3,950	5%	2,130	3%	5,870	7%	12,200	15%
Room Lower Floor	756	0%	1,510	0%	2,660	1%	1,400	0%	1,980	0%	0	0%	1,470	0%	2,700	24%
Room Mid Floor	1,840	0%	6,610	1%	14,600	0%	8,150	0%	0	0%	2,190	0%	1,980	0%	2,480	13%
Room Upper Floor	1,876	0%	3,820	0%	9,200	0%	6,740	0%	0	0%	0	0%	2,440	0%	2,880	12%

FUSED ELEMENTS RESIDENCE										
Load Total Summary - System										
(Includes Ventilation and Infiltration Loads)										
Location	Area	CFM	Peak	Cooling	Heating					
Base Floor Elements	6,440	1,000	7,100	1,000	4,476					
Room Lower Floor	1,810	410	1,810	453	756					
Room Mid Floor	2,990	410	2,990	2,230	1,840					
Room Upper Floor	1,620	698	1,620	2,230	1,876					

FUSED ELEMENTS RESIDENCE										
Load Total Summary - Room										
(Includes Ventilation and Infiltration Loads)										
Location	Area	CFM	Peak	Cooling	Heating					
Base Floor Elements	6,440	1,000	7,100	1,000	4,476					
Room Lower Floor	1,810	410	1,810	453	756					
Room Mid Floor	2,990	410	2,990	2,230	1,840					
Room Upper Floor	1,620	698	1,620	2,230	1,876					

FUSED ELEMENTS RESIDENCE										
Door Types										
Door Type	U-Value	ASHRAE Type	Color	Description						
DOOR	0.3			DOOR						

FUSED ELEMENTS RESIDENCE				
Doors				
Room Number	Area	Type	Facing Direction	U-Value
Lower Floor	27	DOOR	S	
Mid Floor	31	DOOR	N	
Mid Floor	31	DOOR	N	
Mid Floor	28	DOOR	E	
Mid Floor	24	DOOR	E	
Upper Floor	21	DOOR	S	
Upper Floor	24	DOOR	E	

FUSED ELEMENTS RESIDENCE										
Glass Types										
Glass Type	U-Value	SHGC	Description							
GLASS	0.3		GLASS							
SKYLIGHT	0.3		SKYLIGHT							

FUSED ELEMENTS RESIDENCE				
Glass				
Room Number	Area	Type	Facing Direction	Shaded
Lower Floor	264	GLASS	W	
Mid Floor	39	GLASS	N	
Mid Floor	31	GLASS	N	
Mid Floor	352	GLASS	W	
Mid Floor	172	GLASS	W	
Mid Floor	22	GLASS	W	
Mid Floor	67	GLASS	S	
Mid Floor	174	GLASS	S	
Upper Floor	229	GLASS	E	
Upper Floor	54	SKYLIGHT	Sky	
Upper Floor	60	GLASS	N	
Upper Floor	34	GLASS	N	
Upper Floor	104	GLASS	W	
Upper Floor	214	GLASS	W	
Upper Floor	110	GLASS	S	
Upper Floor	18	GLASS	E	
Upper Floor	11	GLASS	E	
Upper Floor	62	GLASS	N	

FUSED ELEMENTS RESIDENCE										
Room Information, Part 1										
(Mainly to be used to size equipment)										
Number	Area	Cooling (BTU/hr)	Heating (BTU/hr)	Ventilation (CFM)	Infiltration (CFM)	Cooling (CFM)	Heating (CFM)	Return (CFM)	Reference	Remarks
Lower Floor	1,810	453	756	410	122	2,891	1,470	2,891	79 F	79 F
Mid Floor	2,990	2,230	1,840	410	122	2,891	1,470	2,891	79 F	79 F
Upper Floor	1,620	698	1,876	698	122	2,891	1,470	2,891	79 F	79 F

FUSED ELEMENTS RESIDENCE				
Room Information, Part 2				
Number	Lighting Load (W)	Equipment Load (W)	People (per room)	Zone Type
Lower Floor	0.8 w/m² (8.150)	0.5 w/m² (4.680)	3 people	250
Mid Floor	0.8 w/m² (8.150)	0.5 w/m² (4.680)	3 people	250
Upper Floor	0.8 w/m² (8.150)	0.5 w/m² (4.680)	3 people	250

FUSED ELEMENTS RESIDENCE										
Room Information, Part 1										
(Mainly to be used to size equipment)										
Number	Area	Cooling (BTU/hr)	Heating (BTU/hr)	Ventilation (CFM)	Infiltration (CFM)	Cooling (CFM)	Heating (CFM)	Return (CFM)	Reference	Remarks
Lower Floor	1,810	453	756	410	122	2,891	1,470	2,891	79 F	79 F
Mid Floor	2,990	2,230	1,840	410	122	2,891	1,470	2,891	79 F	79 F
Upper Floor	1,620	698	1,876	698	122	2,891	1,470	2,891	79 F	79 F

FUSED ELEMENTS RESIDENCE				
Room Information, Part 2				
Number	Lighting Load (W)	Equipment Load (W)	People (per room)	Zone Type
Lower Floor	0.8 w/m² (8.150)	0.5 w/m² (4.680)	3 people	250
Mid Floor	0.8 w/m² (8.150)	0.5 w/m² (4.680)	3 people	250
Upper Floor	0.8 w/m² (8.150)	0.5 w/m² (4.680)	3 people	250

See IFP/1216-001 Fused Elements Residence (Chase)/Design/Inac-load-1884

FUSED ELEMENTS RESIDENCE										
Project Information										
Project Name:	FUSED ELEMENTS RESIDENCE									
Project Location:	BELLEVUE, WA									
Project Start:	9/15/2023									
Design Basis:	September 4, 2023, 8:30 AM									

FUSED ELEMENTS RESIDENCE										
Roof Types										
Roof Type	U-Value	ASHRAE Type	Color	Description						
ROOF	0.032			ROOF						

FUSED ELEMENTS RESIDENCE				
Roofs				
Location	Type	Area	% of Room	U-Value
Room Lower Floor	ROOF		0.0%	0.032
Room Mid Floor	ROOF		0.0%	0.032
Room Upper Floor	ROOF		0.0%	0.032

FUSED ELEMENTS RESIDENCE										
Wall Types										
Wall Type	U-Value	ASHRAE Type	Color	Description						
BELOW GRADE WALL	0.06			BELOW GRADE WALL						
WALL	0.06			WALL						

FUSED ELEMENTS RESIDENCE										
Walls										
Room Number	Length	Height	Area (Other Doors and Glass)	Type	Facing Direction	On-Perimeter				
Lower Floor	89.27'	12'	269	WALL	W					
Lower Floor	147.41'	12'	472	WALL	E					
Mid Floor	87'	10'	87	WALL	N					
Mid Floor	127.17'	10'	127	WALL	N					
Mid Floor	47.41'	10'	47	WALL	N					
Mid Floor	19.84'	10'	19	WALL	N					
Mid Floor	48.4'	10'	48	WALL	W					
Mid Floor	27'	10'	27	WALL	W					
Upper Floor	33.47'	10'	33	WALL	W					
Upper Floor	20.17'	10'	20	WALL	S					
Upper Floor	32.17'	10'	32	WALL	S					
Upper Floor	7'	10'	7	WALL	E					
Upper Floor	27'	10'	27	WALL	E					
Upper Floor	32.47'	10'	32	WALL	E					

FUSED ELEMENTS RESIDENCE										
Walls										
Room Number	Length	Height	Area (Other Doors and Glass)	Type	Facing Direction	On-Perimeter				
Mid Floor	20.17'	10'	20	WALL	E					
Mid Floor	33.47'	10'	33	WALL	E					
Mid Floor	21'	10'	21	WALL	E					
Mid Floor	77'	10'	77	WALL	E					
Mid Floor	18.14'	10'	18	WALL	N					
Upper Floor	18.14'	10'	18	WALL	N					
Upper Floor	19'	10'	19	WALL	N					
Upper Floor	41.17'	10'	41	WALL	N					
Upper Floor	13.37'	10'	13	WALL	W					
Upper Floor	33.47'	10'	33	WALL	W					
Upper Floor	40.87'	10'	41	WALL	W					
Upper Floor	27.17'	10'	27	WALL	E					
Upper Floor	21'	10'	21	WALL	E					
Upper Floor	32.47'	10'	32	WALL	E					

FUSED ELEMENTS RESIDENCE										
Partitions										
Location	Type	Area	Low Temperature	High Temperature	U-Value					
Room Lower Floor	Wall	154	O&A Low	O&A High	0.05					
Room Lower Floor	Wall	262	O&A Low	O&A High	0.05					
Room Lower Floor	Wall	119	O&A Low	O&A High	0.05					
Room Lower Floor	Wall	112	O&A Low	O&A High	0.05					
Room Lower Floor	Wall	99	O&A Low	O&A High	0.05					
Room Lower Floor	Wall	161	O&A Low	O&A High	0.05					
Room Lower Floor	Door	32	O&A Low	O&A High	0.3					
Room Lower Floor	Wall	153	O&A Low	O&A High	0.05					
Room Lower Floor	Wall	230	O&A Low	O&A High	0.05					
Room Lower Floor	Door	32	O&A Low	O&A High	0.3					
Room Mid Floor	Woods	1,730	100% of Room	O&A Low	0.05					

FUSED ELEMENTS RESIDENCE										
Door Types										
Door Type	U-Value	ASHRAE Type	Color	Description						
DOOR	0.3			DOOR						

FUSED ELEMENTS RESIDENCE				
Doors				
Room Number	Area	Type	Facing Direction	U-Value
Lower Floor	27	DOOR	S	
Mid Floor	31	DOOR	N	
Mid Floor	31	DOOR	N	
Mid Floor	28	DOOR	E	
Mid Floor	24	DOOR	E	
Upper Floor	21	DOOR	S	
Upper Floor	24	DOOR	E	

FUSED ELEMENTS RESIDENCE										
Glass Types										
Glass Type	U-Value	SHGC	Description							
GLASS	0.3		GLASS							
SKYLIGHT	0.3		SKYLIGHT							

FUSED ELEMENTS RESIDENCE				
Glass				
Room Number	Area	Type	Facing Direction	Shaded
Lower Floor	264	GLASS	W	
Mid Floor	39	GLASS	N	
Mid Floor	31	GLASS	N	
Mid Floor	352	GLASS	W	
Mid Floor	172	GLASS	W	
Mid Floor	22	GLASS	W	
Mid Floor	67	GLASS	S	
Mid Floor	174	GLASS	S	
Upper Floor	229	GLASS	E	
Upper Floor	54	SKYLIGHT	Sky	
Upper Floor	60	GLASS	N	
Upper Floor	34	GLASS	N	
Upper Floor	104	GLASS	W	
Upper Floor	214	GLASS	W	
Upper Floor	110	GLASS	S	
Upper Floor	18	GLASS	E	
Upper Floor	11	GLASS	E	
Upper Floor	62	GLASS	N	

FUSED ELEMENTS RESIDENCE										
Room Information, Part 1										
(Mainly to be used to size equipment)										
Number	Area	Cooling (BTU/hr)	Heating (BTU/hr)	Ventilation (CFM)	Infiltration (CFM)	Cooling (CFM)	Heating (CFM)	Return (CFM)	Reference	Remarks
Lower Floor	1,810	453	756	410	122	2,891	1,470	2,891	79 F	79 F
Mid Floor	2,990	2,230	1,840	410	122	2,891	1,470	2,891	79 F	79 F
Upper Floor	1,620	698	1,876	698	122	2,891	1,470	2,891	79 F	79 F

FUSED ELEMENTS RESIDENCE				
Room Information, Part 2				
Number	Lighting Load (W)	Equipment Load (W)	People (per room)	Zone Type
Lower Floor	0.8 w/m² (8.150)	0.5 w/m² (4.680)	3 people	250
Mid Floor	0.8 w/m² (8.150)	0.5 w/m² (4.680)	3 people	250
Upper Floor	0.8 w/m² (8.150)	0.5 w/m² (4.680)	3 people	250

See IFP/1216-001 Fused Elements Residence (Chase)/Design/Inac-load-1884

LEGEND

Table with two columns: Symbol/Abbreviation and Description. Includes categories like AIR CONDITIONING UNIT, EQUIPMENT, GENERAL, SECTION IDENTIFICATION, CONDENSATE DRAINAGE, NATURAL GAS, WASTE, PUMPED WASTE, RAIN LEADER, OVERFLOW RAIN LEADER, PUMPED RAIN LEADER, VENT, COLD WATER, HOT WATER, POTABLE, TEMPERATURE OTHER THAN 120°F, HOT WATER CIRCULATING (HWC), POTABLE, TEMPERATURE OTHER THAN 120°F, IRRIGATION, PIPE PLUG, UNION, FLANGE, GATE VALVE, BALL VALVE, BALL VALVE, PRESSURE REDUCING VALVE (PRV), BREAK IN PIPING OR DUCTWORK, CHECK VALVE, BALANCING OR PLUG VALVE, BALANCING/MEASURING VALVE, INDIRECT DRAIN, PIPE TO DRAIN, GLOBE VALVE, BUTTERFLY VALVE, WYE STRAINER, WYE STRAINER WITH CAPPED HOSE, END BLOWDOWN VALVE, AUTOMATIC CONTROL VALVE, 2-WAY, AUTOMATIC CONTROL VALVE, 3-WAY, RELIEF VALVE, REDUCED PRESSURE BACKFLOW PREVENTER, DOUBLE CHECK VALVE ASSEMBLY, FLOOR DRAIN, HOSE BIBB, PIPE ALIGNMENT GUIDE, FLEXIBLE CONNECTION IN PIPING, PIPE SUPPORT, PIPE ANCHOR, PRESSURE GAGE, THERMOMETER, PRESSURE / TEMPERATURE TEST PORT, VALVE STATION OR ASSEMBLY, PUMP, WASTE/VENT RISER CALLOUT, and CW/HW RISER CALLOUT.

GENERAL NOTES

- GENERAL NOTES - MECHANICAL
1. REFERENCE TO RELATED WORK: "REF" INDICATIONS DENOTE WORK COVERED ELSEWHERE...
2. ELECTRICAL CHARACTERISTICS: REFER TO ELECTRICAL DRAWINGS FOR ELECTRICAL CHARACTERISTICS...
3. CODES: COMPLETE INSTALLATION OF THE MECHANICAL SYSTEM SHALL BE PER THE APPLICABLE BUILDING, MECHANICAL, ENERGY, PLUMBING, FIRE, AND HEALTH CODES...
4. PREPARE AND SUBMIT FOR REVIEW A SHOP DRAWING...
5. MECHANICAL CONTRACTOR SHALL LOCATE AND COORDINATE EXACT LOCATION OF ALL MECHANICAL EQUIPMENT...
6. ACCESS DOORS: COORDINATE WITH ARCHITECT AND LOCATE ALL ACCESS DOORS...
7. ROOF PENETRATIONS: SEE ARCHITECTURAL DRAWINGS FOR ROOF CAP, ROOF CURB, ROOF DRAIN, AND VTR DETAILS.
8. EXPOSED PIPING: PROVIDE CHROME PLATING FOR EXPOSED PIPING IN FINISHED ROOMS.
9. PENETRATIONS: PROVIDE ESCOTCHONE PLATES FOR EXPOSED PIPING PENETRATIONS AND SHEET METAL FLASHING FOR EXPOSED DUCTWORK PENETRATIONS.
10. SHAFT AND PLENUM CONNECTIONS: SEAL CONNECTIONS TO AIR SHAFTS AIRTIGHT...
11. LIGHT FIXTURE CLEARANCE: COORDINATE LOCATIONS OF MECHANICAL WORK TO PROVIDE CLEARANCES OVER LIGHTING FIXTURES FOR REMOVAL AND REPLACEMENT.
12. CABLE TRAYS: DUCTWORK AND PIPING INSTALLED ADJACENT TO ELECTRICAL CABLE TRAYS SHALL ALLOW MINIMUM ACCESS OF 6" ABOVE AND TO THE SIDE OF CABLE TRAYS.
13. ACCESS CLEARANCES FOR MAINTENANCE AND REPLACEMENT: VERIFY PHYSICAL DIMENSIONS OF EQUIPMENT TO ENSURE THAT ACCESS CLEARANCES CAN BE MET.
COORDINATION REQUIREMENTS
1. IRRIGATION: COORDINATE WITH IRRIGATION CONTRACTOR FOR THEIR WATER SUPPLY REQUIREMENTS AND LOCATIONS.
2. UTILITIES: COORDINATE WITH SITE UTILITY CONTRACTOR AND CIVIL DRAWINGS FOR UTILITY CONNECTIONS AND EXTENSIONS.
3. ROOF DRAINAGE: COORDINATE WITH GENERAL CONTRACTOR FOR ROOF DRAIN AND OVERFLOWS, SCUPPER DRAINS, AND CONDENSATE DRAINS.
4. STORM DRAINAGE: VERIFY WITH GENERAL CONTRACTOR FOR STORM DRAINAGE PRIOR TO BIDDING.
5. PLUMBING FIXTURES: COORDINATE WITH ARCHITECTURAL AND OTHER TRADES EXACT LOCATION OF ALL PLUMBING FIXTURES.
6. PIPING: COORDINATE WITH STRUCTURAL FOR EXACT LOCATION OF ALL STRUCTURAL FRAMING AND FOOTINGS AND FINALIZE THE EXACT ROUTING OF ALL PIPES WITH STRUCTURAL AND AT THE SITE PRIOR AND DURING THE CONSTRUCTION.
7. ADJUSTMENTS: ALL EQUIPMENT, MOTORS, FANS GAS BURNERS, IGNITION DEVICES, DRIVES, ETC. SHALL BE ADJUSTED AND BALANCED TO OPERATE AT SPECIFIED RATINGS AS REQUIRED FOR THIS PROJECT SITE AND ACCOUNTING FOR ELEVATION ABOVE SEA LEVEL.
8. APPROVALS: MECHANICAL AND PLUMBING EQUIPMENT SHALL BE APPROVED FOR INSTALLATION IN THE PROJECT LOCATION AND SHALL HAVE ALL CERTIFICATIONS AND RATINGS TO MEET ALL ENERGY, POLLUTION, ENVIRONMENTAL, SEISMIC, ETC. CODES AND REGULATIONS. THE CONTRACTOR SHALL COORDINATE WITH HIS MANUFACTURE SUPPLIERS AND SHALL INCLUDE ALL COSTS REQUIRED TO MEET THESE REQUIREMENTS IN HIS BID.

DRAWINGS ARE DIAGRAMMATIC, SHOWING THE GENERAL LOCATION, TYPE, LAYOUT, AND EQUIPMENT REQUIRED. THE DRAWINGS SHALL NOT BE SCALED FOR EXACT MEASUREMENT. REFER TO ARCHITECTURAL DRAWINGS FOR DIMENSIONS. REFER TO MANUFACTURER'S STANDARD INSTALLATION DRAWINGS FOR EQUIPMENT CONNECTIONS AND INSTALLATION REQUIREMENTS. PROVIDE DUCTWORK, CONNECTIONS, ACCESSORIES, OFFSETS, AND MATERIALS NECESSARY FOR A COMPLETE SYSTEM.

PIPING NOTES

- 1. DISASSEMBLY PROVISIONS: PROVIDE UNIONS OR FLANGES AT PIPING CONNECTIONS TO EQUIPMENT, COILS, TRAPS, CONTROL VALVES, AND OTHER COMPONENTS TO ALLOW DISASSEMBLY FOR MAINTENANCE.
2. REDUCERS: PROVIDE AS REQUIRED FROM LINE PIPE SIZE TO EQUIPMENT, TRAP, COIL, AND CONTROL VALVE CONNECTION SIZES.
3. OFFSETS: PROVIDE FOR BRANCH LINES TO EQUIPMENT.
4. DIELECTRIC UNIONS: PROVIDE AT CONNECTIONS OF DISSIMILAR PIPE.
5. REFRIGERANT PIPING: PROVIDE SIZING & INSTALLATION IN STRICT ACCORDANCE WITH MANUFACTURER'S INSTRUCTIONS.
6. CONDENSATE DRAIN: PROVIDE A P-TRAP FOR EACH HVAC UNIT CONDENSATE PAN WITH PLUG TEES FOR CLEANING. CONDENSATE DRAINS SHALL BE DISCHARGED TO AN INDIRECT WASTE OR OUTSIDE.
PLUMBING NOTES
1. CONNECTIONS: PROVIDE PLUMBING FIXTURE CONNECTIONS TO BUILDING WASTE, VENT, COLD WATER, AND HOT WATER SYSTEM IN ACCORDANCE WITH DRAWINGS, MANUFACTURER'S RECOMMENDATIONS, AND LOCAL CODES.
2. HOT AND COLD: WATER PIPING CONNECTION TO EACH FIXTURE THE LEFT HAND SIDE.
3. VENT STACKS: COORDINATE VENT STACK WITH HVAC EQUIPMENT TO MAINTAIN MINIMUM 10' CLEARANCE FROM OUTSIDE AIR INTAKES.
4. CLEANOUTS: PROVIDE CLEANOUTS PER CURRENT UPC AND AS REQUIRED BY LOCAL JURISDICTIONS. CLEANOUTS SHALL BE LOCATED IN WALLS/FLOORS WHERE THEY ARE NOT HIGHLY VISIBLE. FLOOR CLEANOUTS IN CARPETED AREAS TO BE FITTED WITH CARPET INSERTS. LOCATIONS SHALL BE SUBMITTED TO ARCHITECT FOR DRAWINGS.
5. SUDS RELIEF: PROVIDE SUDS RELIEF IN ACCORDANCE WITH CURRENT UPC.
6. SHUT-OFFS: PROVIDE SHUT-OFF VALVES/STOPS AT HOT AND COLD WATER SUPPLY TO EACH FIXTURE. EXCEPTION: PROVIDE SCREWDRIVER STOPS AT BATH/SHOWERS.
7. TRAP ARMS: PROVIDE TRAP ARMS SUCH THAT THE MAXIMUM LENGTH WILL NOT EXCEED CODE REQUIREMENTS.
8. ADA INSULATION: AT PLUMBING PIPING EXPOSED UNDER LAVATOIRES, INSULATE THE EXPOSED PIPING AND TRAPS WITH PRODUCT SPECIFICALLY DESIGNED FOR THIS APPLICATION MEETING ADA REQUIREMENTS. PROVIDE HAND-LAY GUARD OR EQUIVALENT. OFFSET P-TRAPS TO CLEAR WHEELCHAIR ACCESS.
9. FREEZE PROTECTION: WATER PIPING SHALL BE INSTALLED ON THE WARM SIDE OF INSULATION. ROUTE NO WATER PIPING IN ATTIC SPACE. HEAT TAPING IS NOT ACCEPTABLE.
10. WATER HAMMER ARRESTERS: PROVIDE AT THE END OF HOT AND COLD WATER LINES SERVING TWO OR MORE FIXTURES. SIZE IN ACCORDANCE WITH PLUMBING AND DRAINAGE INSTITUTE (PDI) REQUIREMENTS. WATER HAMMER ARRESTORS ARE REQUIRED FOR QUICK CLOSING VALVES, SUCH AS LAUNDRY WASHERS, FLUSH VALVES (PUBLIC TOILETS), ETC. MODEL PPP MIL-D-82036 OR EQUAL. VERIFY SIZE BEFORE ORDERING.
11. TRAP PRIMERS: PROVIDE TRAP PRIMERS AND PIPING FOR DRAINS AND FLOOR SINKS. ARRANGE PIPING TO ACHIEVE EQUAL FLOW TO EACH DRAIN AND FLOOR SINK FOR TRAP PRIMERS SERVING MULTIPLE DRAINS AND FLOOR SINKS.

PRE-CON MEETING

CONTRACTORS SHALL ATTEND A PRE-CONSTRUCTION MEETING WITH THE ENGINEER FOR THE PURPOSE OF REVIEWING THE WORK PRIOR TO ORDERING ANY EQUIPMENT OR PERFORMING ANY WORK. THE MEETING SHALL BE LOCATED AT THE PROJECT SITE ON A DATE AND TIME TO BE MUTUALLY AGREED. THE MEETING WILL BE FACILITATED BY THE ENGINEER AND THE AGENDA WILL INCLUDE A DETAILED REVIEW OF THE PLANS AND SPECIFICATIONS, CROSS CHECK WITH OTHER TRADES FOR COORDINATION ISSUES, REVIEW OF PROPOSED PRODUCTS, REVIEW OF PLANNED MEANS AND METHODS, AND ON-SITE INVESTIGATION OF FIELD CONDITIONS RELATIVE TO EXISTING CONDITIONS THAT COULD AFFECT THE WORK.

Table with 2 columns: Trade and Hours. Includes Mechanical Sheet Metal (2 hours), Plumbing/Piping (2 hours), Electrical (2 hours), and General Contractor (all sessions).

APPLICABLE CODES

- THESE DRAWINGS ARE BASED ON THE FOLLOWING CODES:
-2018 INTERNATIONAL RESIDENTIAL CODE
-2018 UNIFORM PLUMBING CODE
-2018 WASHINGTON STATE ENERGY CODE - RESIDENTIAL PROVISIONS

Olson Kundig logo and address: 15000 1st Avenue SE, Mercer Island, WA 98040. Project name: FUSED ELEMENTS.

Robison Engineering, Inc. logo and address: 14641 Aurora St, Suite 300, Lynnwood, WA 98036. Includes a professional seal for a Licensed Professional Engineer in Washington State.

Table with 4 columns: DWG, Description, Includer in Set, and Sheets with Revisions. Shows DWG P0.00 and P0.01 included in the permit set and revision set.

DRAWING INDEX

Table with 4 columns: DWG, Description, Includer in Set, and Sheets with Revisions. Lists drawings P0.00 through P4.00 and their inclusion status in the permit and revision sets.

project architect: JAN
project manager: JAN
drawn by: JAN
checked by: FR
job no.: 1216-001

revisions:
1 2/23/24 PERMIT REVISION SET

no. date description:
NOT FOR CONSTRUCTION

PERMIT SET
2/23/2024

title:
LEGEND, GENERAL NOTES, DRAWING INDEX

sheet:
P0.00

CALCULATIONS

Robison Engineering, Inc.
19401 40th Ave W, Suite 302
Lynnwood, WA 98006
Project Name: Fused Elements
Project Number: 1216-001
Edited By: JAN
Edit Date: 6/14/2023

SIZING IS PER UPC

WATER SUPPLY PIPE SIZING CALCULATION FORM

WATER PRESSURE AT STREET: 70 PSI STATIC PRESSURE
WATER METER LOSS: 5 PSI
BACKFLOW PREVENTER LOSS: 7 PSI
FRICTION LOSS: 5 PSI
LOSS FROM STREET TO BUILDING: 53 PSI
AVAILABLE PRESSURE AFTER BACKFLOW: 10.8 PSI
STATIC LIFT TO HIGHEST FIXTURE: 25 FEET = 10.8 PSI
REQUIRED MINIMUM PRESSURE AT FURTHEST PLUMBING MANIFOLD: 25 PSI
PRESSURE AVAILABLE TO OFFSET FRICTION LOSSES: 17.2 PSI
PPING SYSTEM LENGTH FROM SERVICE TO FURTHEST MANIFOLD: 225 FEET
FITTING ALLOWANCE: 100 FEET
MAXIMUM FRICTION LOSS FACTOR: 5.3 PSI/100 FT
SELECTED FRICTION LOSS FACTOR: 5.3 PSI/100 FT
MAX HW & CW VELOCITY 8 FPS (SCH 40)
MAX HW & CW VELOCITY 5 FPS (SCH 80)

SUPPLY PIPE SIZING SCHEDULE				
PIPE SIZE	FLOW, GPM	VELOCITY FPS	FIXTURE UNITS	PIPE MATERIAL
1/2"	2.0	3.60	2.0	CPVC SCH 40
3/4"	5.0	4.60	5.5	CPVC SCH 40
1"	10.0	5.50	13.0	CPVC SCH 40
1-1/4"	20.0	7.00	26.0	CPVC SCH 40
2"	50.0	8.00	130.0	CPVC SCH 40

SCHEDULES

PIPE MATERIALS SCHEDULE			
SERVICE	MATERIAL	JOINT	NOTES
WATER DISTRIBUTION PIPING 4" & LARGER	COPPER TYPE L	SOLDER	(1)(2)(3)
WATER DISTRIBUTION PIPING, 3" & SMALLER	PEX	COLD EXPANSION FITTINGS	(1)(2)(3)
WATER DISTRIBUTION PIPING WITHIN RESIDENTIAL UNITS	PEX	COLD EXPANSION FITTINGS	(1)(2)
SANITARY SEWER & VENT PIPING, BELOW GRADE	PVC SCH 40	SOLVENT CEMENT	(1)(2)(3)(5)(6)
SANITARY SEWER & VENT PIPING, ABOVE GRADE	ABS SCH 40	SOLVENT CEMENT	(1)(2)(4)(5)(6)(7)(8)
STORM DRAIN PIPING, BELOW GRADE	PVC SCH 40	SOLVENT CEMENT	(1)(2)(3)
STORM DRAIN PIPING, ABOVE GRADE	ABS SCH 40	SOLVENT CEMENT	(1)(2)(4)(7)(8)
CONDENSATE DRAIN PIPING	CPVC SCH 40	SOLVENT CEMENT	(1)(2)

- NOTES: (1) PIPE MATERIALS SHALL BE LISTED BY AN APPROVED LISTING AGENCY.
(2) CONTRACTOR SHALL INDICATE THE TYPE OF PIPE MATERIALS INCLUDED IN THEIR BID. ALTERNATE PIPE MATERIALS SHALL BE SUBMITTED TO THE OWNER AND THE ENGINEER FOR APPROVAL PRIOR TO INSTALLATION.
(3) PLASTIC WRAP UNDERGROUND SUPPLY PIPING TO PREVENT CORROSION.
(4) HORIZONTAL OFFSETS IN DWELLING UNIT CEILINGS OR NOISE-SENSITIVE AREAS SHALL BE CAST IRON OR ACOUSTICALLY INSULATED.
(5) PROVIDE THERMAL EXPANSION COMPENSATION FOR ALL PLASTIC PIPING PER MANUFACTURER REQUIREMENTS.
(6) PVC PIPING SHALL NOT BE USED FOR RECEPTOR AND TRAP ARM WHERE WASTE TEMPERATURE CAN EXCEED 110°F. THIS INCLUDES PIPING AND RECEPTORS FOR 3 COMPARTMENT SINK, COMMERCIAL DISHWASHER, COMMERCIAL LAUNDRY SINK, AND CONDENSATE DRAIN FOR GAS FIRED EQUIPMENT.
(7) TRAP ARM FOR WASTE RECEPTOR OF SODA DISPENSERS SHALL BE PVC. CAST IRON PIPING IS PROHIBITED FOR HIGH ACIDITY DRAINS (PH<3).
(8) ABS/PVC SHALL NOT BE USED IN PLENUM SPACES. PROVIDE SLIDE FITTINGS ON VERTICAL ABS/PVC RISERS EVERY TWO FLOORS, OR PROVIDE SUFFICIENT OFFSETS TO ACCOMMODATE THERMAL EXPANSION.

PIPE INSULATION SCHEDULE								
SERVICE	MATERIAL	NOMINAL PIPE SIZE (IN.)	PIPE INSULATION				VAPOR RETARDER REQUIRED	NOTES
			1/2 - 1	1-1/4	1-1/2	2 AND LARGER		
DOMESTIC HOT WATER AND RECIRCULATED HOT WATER	MINERAL-FIBER WITH JACKET	INSULATION THICKNESS (IN.)	1	1-1/4	1-1/2	2	NO	(1)(2)(3)(4)(5)
EXPOSED SANITARY DRAINS AND DOMESTIC WATER SUPPLIES AND STOPS FOR ADA FIXTURES	TRUEBRO LAV-GUARD		N/A				NO	P-TRAP AND SUPPLY COVERS

- NOTES: (1) FOR APPLICABLE CODES, REFER TO DWG P.D.O.
(2) PIPING INSULATION EXPOSED TO WEATHER SHALL BE PROTECTED FROM DAMAGE. CONTRACTOR SHALL PROVIDE SHIELDING FROM SOLAR RADIATION THAT CAN CAUSE DEGRADATION OF THE MATERIAL. ADHESIVE TAPE SHALL NOT BE PERMITTED.
(3) HOT WATER AND HOT WATER CIRCULATION PIPING SHALL BE INSULATED PER 2015 UPC AND 2015 WSEC.
(4) PER 2015 UPC SECTION 312.6, NO WATER, SOIL OR WASTE PIPE SHALL BE INSTALLED OR PERMITTED OUTSIDE OF THE BUILDING, IN THE ATTIC, OR IN AN EXTERIOR WALL UNLESS ADEQUATE PROVISION IS MADE TO PROTECT SUCH PIPE FROM FREEZING. ALL HOT AND COLD WATER PIPES OUTSIDE THE CONDITIONED SPACE SHALL BE INSULATED TO A MINIMUM OF R-3.
(5) HEAT TRACING SHALL BE PROVIDED FOR COLD WATER AND IRRIGATION WATER IN UNCONDITIONED SPACES. HEAT TRACING OF OUTDOOR PIPING SHALL INCLUDE AUTOMATIC CONTROLS CONFIGURED TO SHUT OFF THE SYSTEM WHEN OUTDOOR AIR TEMPERATURES ARE ABOVE 40°F.

PLUMBING FIXTURE SCHEDULE (NOTE 1)									
EQUIP NO.	FIXTURE TYPE	SERVICE SIZE (INCHES)				MANUFACTURER	MODEL	FINISH	COMMENTS
		CW	HW	W	V				
WC-1	WATER CLOSET	1/2	-	3	2	WATER CLOSET		WHITE	
						SEAT		WHITE	
LAV-1	LAVATORY	1/2	1/2	2	1-1/2	LAVATORY		WHITE	
						FAUCET		CHROME	
BATH-1	BATH/SHOWER	1/2	1/2	2	1-1/2	BATH/TUB		WHITE	
						TRIM KIT		CHROME	
						VALVE		N/A	
						SHOWERHEAD		N/A	
BATH-2	BATH/SHOWER	1/2	1/2	2	1-1/2	BATH/TUB		WHITE	
						TRIM KIT		CHROME	
						VALVE		N/A	
SH-1	SHOWER	1/2	1/2	2	1-1/2	SHOWER ENCLOSURE		WHITE	
						TRIM KIT		CHROME	
						VALVE		N/A	
						SHOWERHEAD		N/A	
SH-2	STEAM SHOWER	1/2	1/2	2	1-1/2	SHOWER ENCLOSURE		WHITE	
						TRIM KIT		CHROME	
						VALVE		N/A	
						SHOWERHEAD		N/A	
SH-3	OUTDOOR SHOWER	1/2	1/2	2	1-1/2	TRIM KIT		CHROME	
						VALVE		N/A	
						SHOWERHEAD		N/A	
SH-4	SHOWER	1/2	1/2	2	1-1/2	SHOWER ENCLOSURE		TILE	
						TRIM KIT		CHROME	
						VALVE		N/A	
						SHOWERHEAD		N/A	
KS-1	KITCHEN SINK	1/2	1/2	2	1-1/2	SINK		STAINLESS STEEL	
						FAUCET		CHROME	
LS-1	LAUNDRY SINK	1/2	1/2	2	1-1/2	SINK		STAINLESS STEEL	
						FAUCET		CHROME	
SK-1	SINK	1/2	1/2	2	1-1/2	SINK		STAINLESS STEEL	
						FAUCET		CHROME	
WB-1	CLOTHES WASHER BOX	1/2	1/2	3	1-1/2			WHITE	
IMB-1	ICE MAKER BOX	1/2	-	-	-			WHITE	
HB-1	WALL HYDRANT	3/4	-	-	-	J.R. SMITH	5509QT	N/A	DR JOSAM, WADE, ZURN
HB-2	ROOF HYDRANT	3/4	-	-	-	J.R. SMITH	5960	N/A	DR JOSAM, WADE, ZURN
HB-3	YARD HYDRANT	3/4	-	-	-	J.R. SMITH	5903	N/A	DR JOSAM, WADE, ZURN
SI-1	SOLIDS INTERCEPTOR	-	-	2	-	ZURN	Z1180	N/A	DR JOSAM, WADE, J.R. SMITH
TD-1	TRENCH DRAIN	-	-	(NOTE 2)	-	J.R. SMITH	2900	NICKEL	DR JOSAM, WADE, ZURN
FD-1	FLOOR DRAIN	-	-	(NOTE 2)	-	J.R. SMITH	2005	NICKEL	DR JOSAM, WADE, ZURN
FS-1	FLOOR SINK	-	-	(NOTE 2)	-	J.R. SMITH	3001	STAINLESS STEEL	DR JOSAM, WADE, ZURN
RD & OD	ROOF/ROOF OVERFLOW DRAIN	-	-	(NOTE 2)	-	J.R. SMITH	1800	N/A	DR JOSAM, WADE, ZURN
WCO	WALL CLEANOUT	-	-	-	-	J.R. SMITH	4420	N/A	DR JOSAM, WADE, ZURN
FCO	FLOOR CLEANOUT	-	-	-	-	J.R. SMITH	4020	N/A	DR JOSAM, WADE, ZURN

- NOTES: (1) CONTRACTOR SHALL CONFIRM MAKE, MODEL, AND FINISH WITH OWNER PRIOR TO ORDERING.
(2) SIZE PER PLANS.

WATER HEATER SCHEDULE - HYBRID						
EQUIP NO.	SERVICE	STORAGE, GAL	ELECTRICAL VOLTAGE	MOCP	UNIFORM ENERGY FACTOR (UEF)	BASIS OF DESIGN
WH-1	HOT WATER	80	230V/1P	30	3.45	A.O. SMITH HPTU-B0N
WH-2	HOT WATER	80	230V/1P	30	3.45	A.O. SMITH HPTU-B0N

- NOTES: (1) INSTALL IN ACCORDANCE WITH MANUFACTURER'S INSTALLATION REQUIREMENTS.

EXPANSION TANK SCHEDULE					
EQUIP NO.	SERVICE	CAPACITY, GAL	TANK SIZE		BASIS OF DESIGN
			DIA	HEIGHT	
ET-1	WH-1 & WH-2	4.4	11	15	AMTROL ST-12C-DD

PUMP SCHEDULE							
EQUIP NO.	SERVICE	TYPE	FLOW, GPM	HEAD, FT	PRESSURE RATING, PSIG	ELECTRICAL VOLTAGE	BASIS OF DESIGN
HWCP-1	HW LOOP	INLINE	3	15	145	115V/1P	BELL & GOSSETT ECOCIRC 20-18 (1)

- NOTES: (1) PROVIDE STAINLESS STEEL PUMP, SUITABLE FOR DOMESTIC WATER APPLICATION.

195 South Jackson St. Suite 100
Seattle, Washington 98104 USA
P: 206.495.4900
www.olsonkundig.com

Olson Kundig

project:
FUSED ELEMENTS
4525 FOREST AVE SE MERCER ISLAND WA 98040



project architect: JAN
project manager: JAN
drawn by: JAN
checked by: PR
job no.: 1216-001

revisions:
1 2/23/24 PERMIT REVISION SET

no.: date: description:
NOT FOR CONSTRUCTION
PERMIT SET

2/23/2024

title:
**CALCULATIONS,
SCHEDULES**

sheet:
P0.01

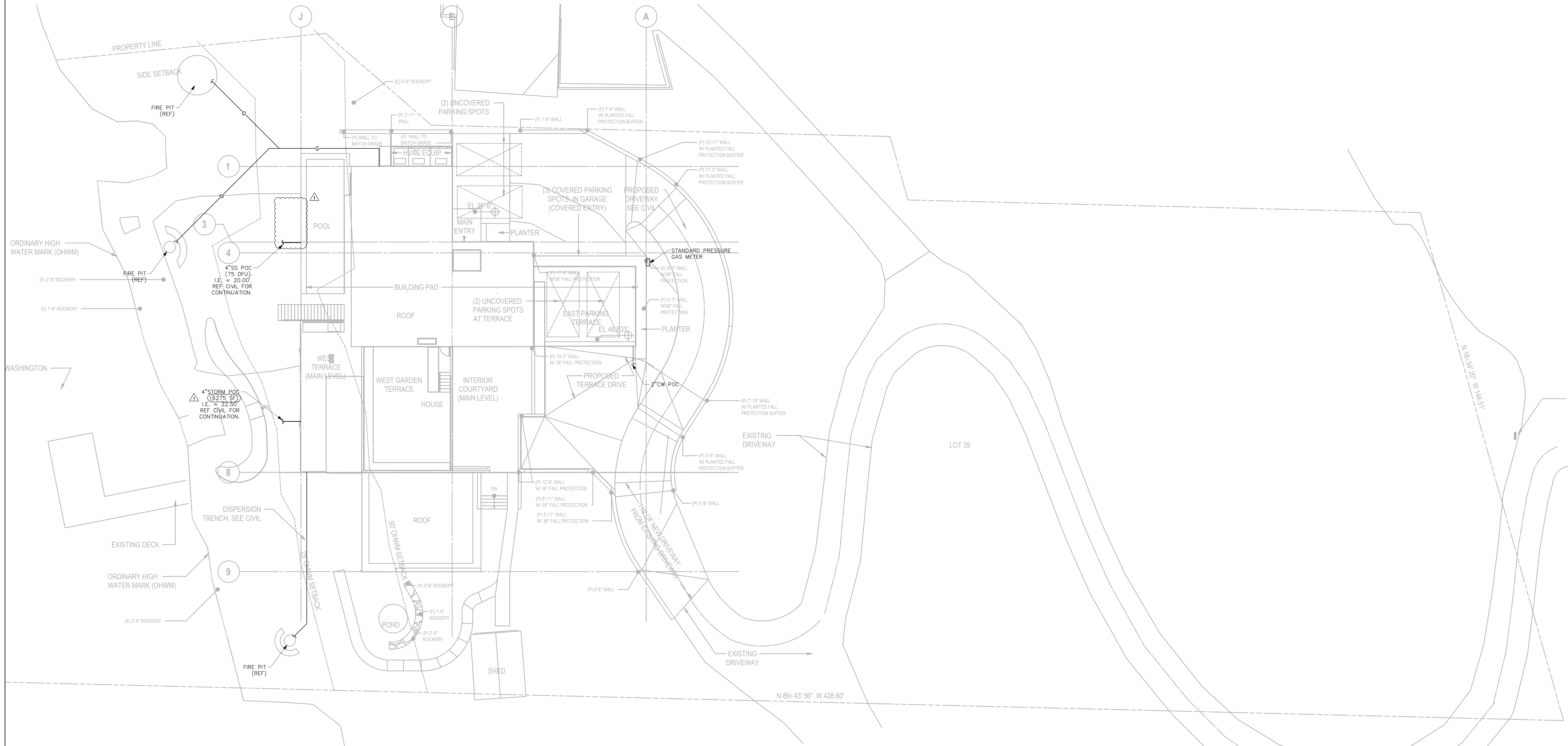

SITE PLAN
SCALE: 1" = 10'

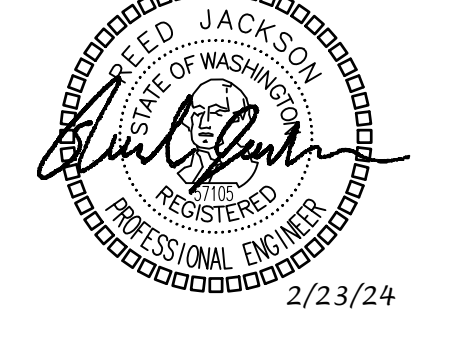

project architect: JMN
project manager: JMN
drawn by: JMN
checked by: PR
job no.: 1216-001

revisions:
1 2/23/24 PERMIT REVISION SET

no. date description:
NOT FOR CONSTRUCTION
PERMIT SET

2/23/2024



title:
SITE PLAN

sheet:
P1.00

STORM DRAIN SIZING:
STORM DRAIN PIPING SIZED PER 2018 UPC, CHAPTER 11, TABLES 1103.1 & 1103.2 FOR 1" PER HOUR RAINFALL RATE. HORIZONTAL PIPING SHALL BE SLOPED 1/8" PER LINEAR FOOT.

SIZE OF PIPE	MAXIMUM ALLOWABLE ROOF AREA (HORIZONTAL PIPING)	MAXIMUM ALLOWABLE ROOF AREA (VERTICAL PIPING)
3"	3,288 SF	8,800 SF
4"	7,520 SF	18,400 SF

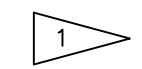
WASTE PIPING SIZING:
HORIZONTAL WASTE PIPING SHALL BE SLOPED AT 1/4" PER LINEAR FOOT. PROVIDE CLEANOUTS PER CURRENT UPC AND AS REQUIRED BY LOCAL JURISDICTIONS. CLEANOUTS SHALL BE LOCATED IN WALLS/FLOORS WHERE THEY ARE NOT HIGHLY VISIBLE. FLOOR CLEANOUTS IN CARPETED AREAS SHALL BE FITTED WITH CARPET INSERTS. LOCATIONS SHALL BE SUBMITTED TO THE ARCHITECT FOR APPROVAL.
NOTE: NOT ALL CLEANOUTS ARE SHOWN ON THE PLUMBING PLANS.

FLAG NOTES:
 4"SS STUB FOR POOL EQUIPMENT.
 24 FIXTURE UNITS ALLOCATED.

155 South Jackson St. Suite 100
 Seattle, Washington 98104 USA
 P: 206.465.4777
 www.olsonkundig.com

Olson Kundig

project:
FUSED ELEMENTS
 4525 FOREST AVE SE MERCER ISLAND WA 98040

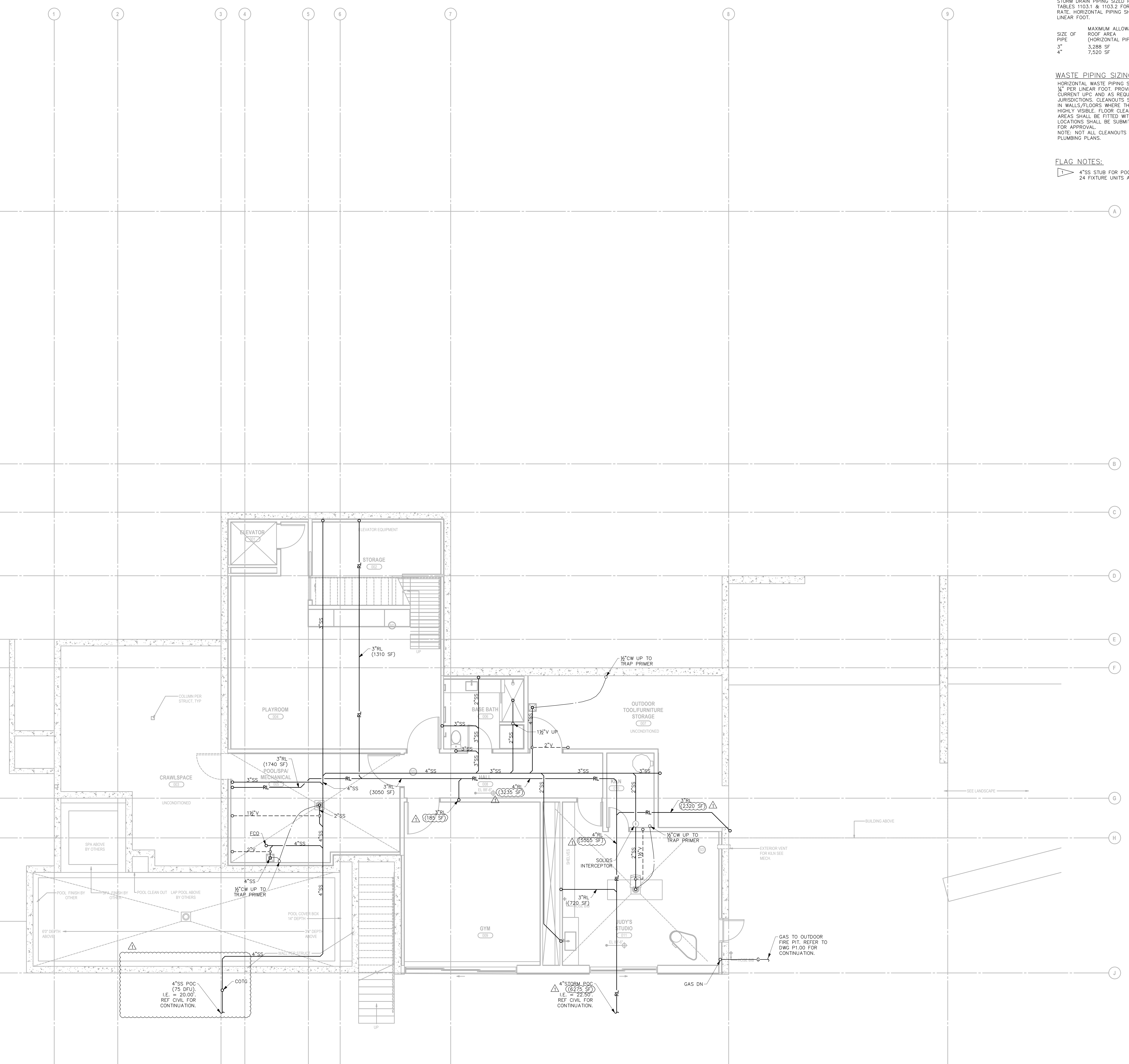
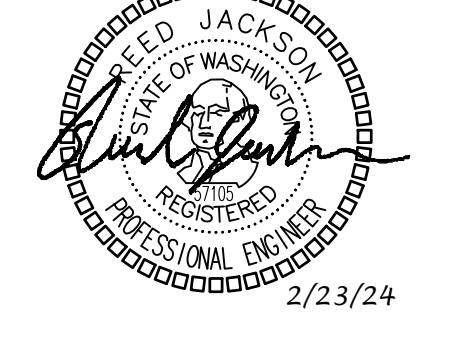
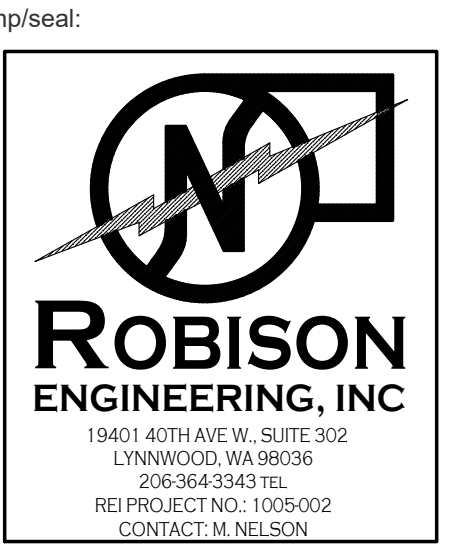

project architect: JMN
 project manager: JMN
 drawn by: JMN
 checked by: PR
 job no.: 1216-001

revisions:
 1 2/23/24 PERMIT REVISION SET

no.: date: description:

NOT FOR CONSTRUCTION
 PERMIT SET
 2/23/2024

title:
UNDERSLAB PLAN

sheet:
P2.00

UNDERSLAB PLAN
 SCALE: 1/4" = 1'-0"

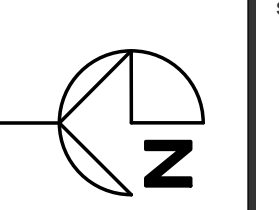

1/23/24 12:15 PM 1216-001 FUSED ELEMENTS RESIDENCE (04)REV02_P2_00 FLOOR PLANS.DWG 08-08-2023 14:37

STORM DRAIN SIZING:
STORM DRAIN PIPING SIZED PER 2018 UPC, CHAPTER 11, TABLES 1103.1 & 1103.2 FOR 1" PER HOUR RAINFALL RATE. HORIZONTAL PIPING SHALL BE SLOPED 1/8" PER LINEAR FOOT.

SIZE OF PIPE	MAXIMUM ALLOWABLE ROOF AREA (HORIZONTAL PIPING)	MAXIMUM ALLOWABLE ROOF AREA (VERTICAL PIPING)
3"	3,288 SF	8,800 SF
4"	7,520 SF	18,400 SF

- FLAG NOTES:**
- 1 HVAC EQUIPMENT (REF).
 - 2 1" CW STUB FOR POOL/SPA EQUIPMENT.
 - 3 DAYLIGHT OVERFLOW RAIN LEADER 6" ABOVE GRADE WITH A BRONZE OVERFLOW NOZZLE.
 - 4 CONDENSATE PUMP (REF). CONDENSATE PUMP PROVIDED BY MECHANICAL CONTRACTOR. PIPING BY PLUMBING CONTRACTOR.
 - 5 DISCHARGE 3/4" SECONDARY CONDENSATE DRAIN TO FLOOR.
 - 6 DISCHARGE 3/4" CONDENSATE DRAIN TO FLOOR SINK WITH A MINIMUM 1" AIR GAP.

GAS PIPING NOTES:
FOR GAS PIPE SIZES, REFER TO DWG 4.00, DETAIL 11.

WASTE PIPING SIZING:
HORIZONTAL WASTE PIPING SHALL BE SLOPED AT 1/4" PER LINEAR FOOT. PROVIDE CLEANOUTS PER CURRENT UPC AND AS REQUIRED BY LOCAL JURISDICTIONS. CLEANOUTS SHALL BE LOCATED IN WALLS/FLOORS WHERE THEY ARE NOT HIGHLY VISIBLE. FLOOR CLEANOUTS IN CARPETED AREAS SHALL BE FITTED WITH CARPET INSERTS. LOCATIONS SHALL BE SUBMITTED TO THE ARCHITECT FOR APPROVAL.
NOTE: NOT ALL CLEANOUTS ARE SHOWN ON THE PLUMBING PLANS.

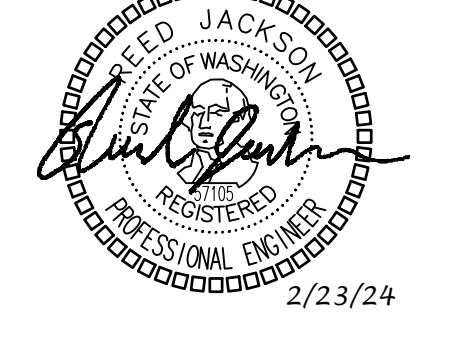

project architect: JMN
project manager: JMN
drawn by: JMN
checked by: PR
job no.: 1216-001

revisions:
1 2/23/24 PERMIT REVISION SET

no. date description:
NOT FOR CONSTRUCTION
PERMIT SET

2/23/2024

title:
LOWER LEVEL FLOOR PLAN

sheet:
P2.10

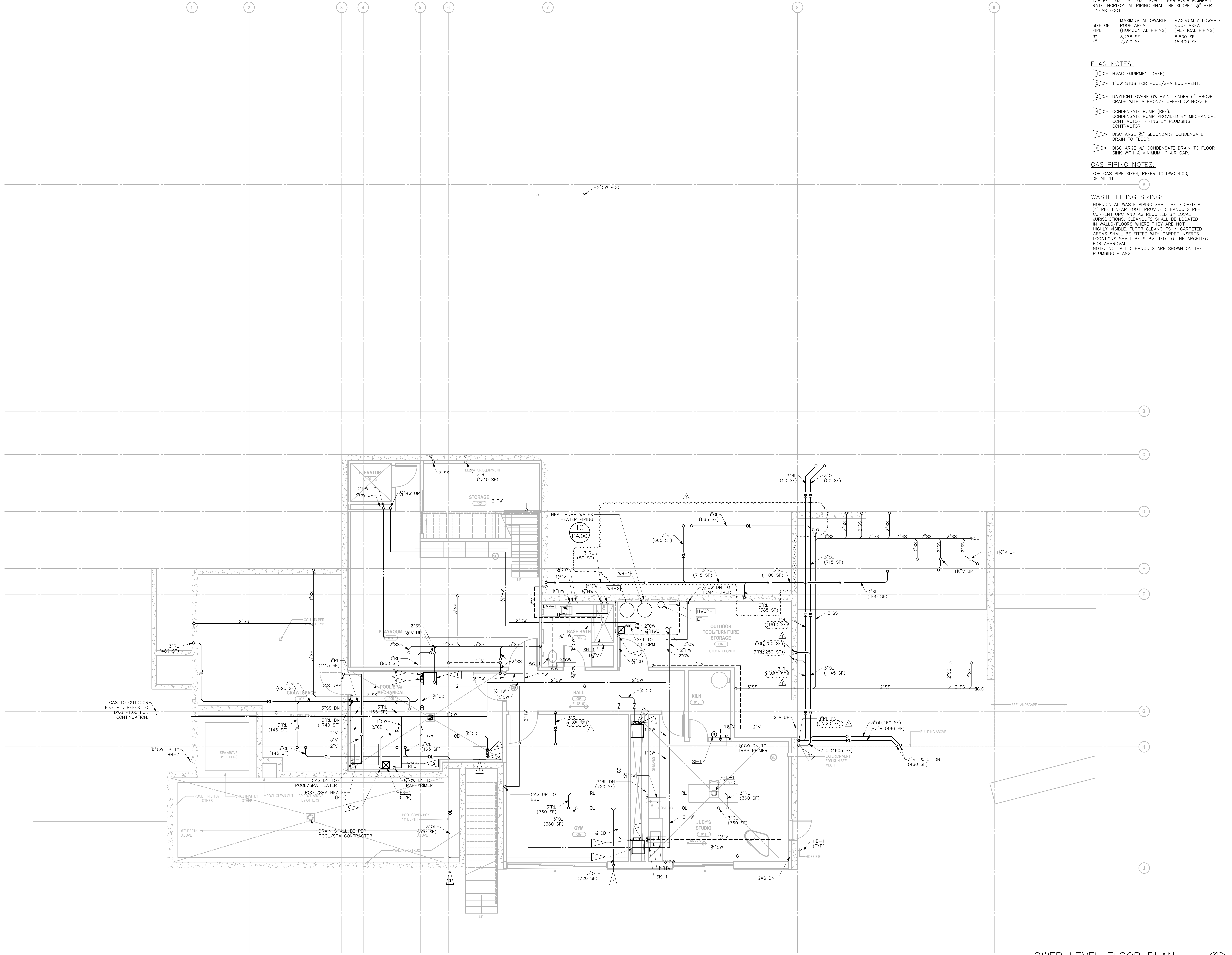

LOWER LEVEL FLOOR PLAN
SCALE: 1/4" = 1'-0"

DATE PLOTTED: 2/23/2024 10:00:00 AM
PROJECT: FUSED ELEMENTS RESIDENCE (204)KND002_20 FLOOR PLANS 08-08-2023 14:37

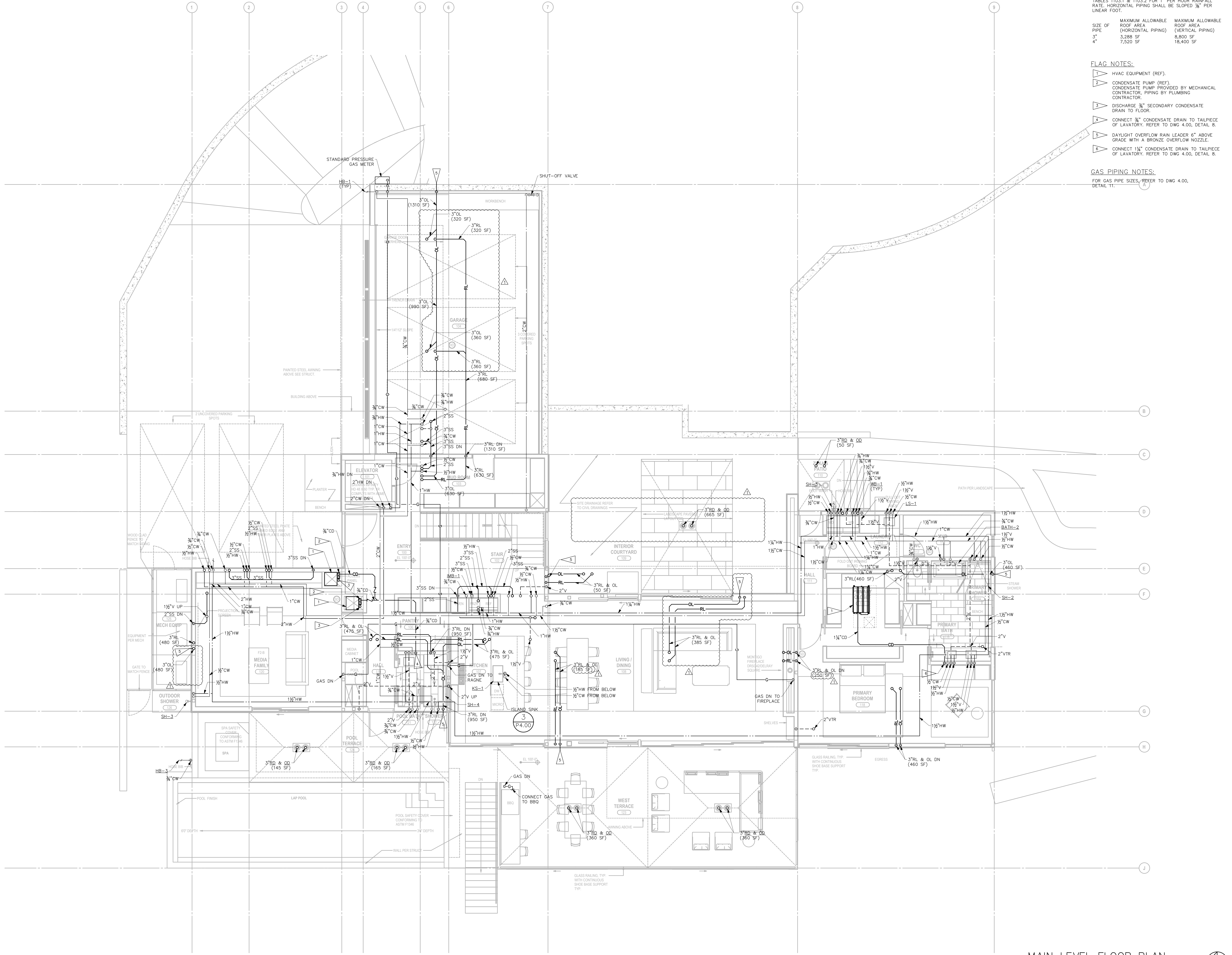

STORM DRAIN SIZING:
 STORM DRAIN SIZED PER 2018 UPC, CHAPTER 11, TABLES 1103.1 & 1103.2 FOR 1" PER HOUR RAINFALL RATE. HORIZONTAL PIPING SHALL BE SLOPED 1/8" PER LINEAR FOOT.

SIZE OF PIPE	MAXIMUM ALLOWABLE ROOF AREA (HORIZONTAL PIPING)	MAXIMUM ALLOWABLE ROOF AREA (VERTICAL PIPING)
3"	3,288 SF	8,800 SF
4"	7,520 SF	18,400 SF

FLAG NOTES:

- HVAC EQUIPMENT (REF).
- CONDENSATE PUMP (REF). CONDENSATE PUMP PROVIDED BY MECHANICAL CONTRACTOR. PIPING BY PLUMBING CONTRACTOR.
- DISCHARGE 3/4" SECONDARY CONDENSATE DRAIN TO FLOOR.
- CONNECT 3/4" CONDENSATE DRAIN TO TAILPIECE OF LAVATORY. REFER TO DWG 4.00, DETAIL 8.
- DAYLIGHT OVERFLOW RAIN LEADER 6" ABOVE GRADE WITH A BRONZE OVERFLOW NOZZLE.
- CONNECT 1 1/4" CONDENSATE DRAIN TO TAILPIECE OF LAVATORY. REFER TO DWG 4.00, DETAIL 8.

GAS PIPING NOTES:
 FOR GAS PIPE SIZES, REFER TO DWG 4.00, DETAIL 11.

Olson Kundig
 project: FUSED ELEMENTS
 4525 FOREST AVE SE MERCER ISLAND WA 98040

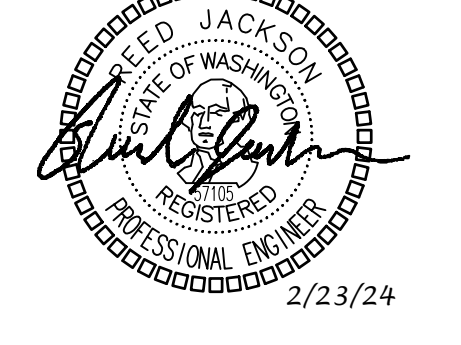

project architect: JMN
 project manager: JMN
 drawn by: JMN
 checked by: PR
 job no.: 1216-001

revisions:
 1 2/23/24 PERMIT REVISION SET

no.: date: description:
 NOT FOR CONSTRUCTION
 PERMIT SET

2/23/2024

title:
 MAIN LEVEL FLOOR PLAN

sheet:
 P2.20



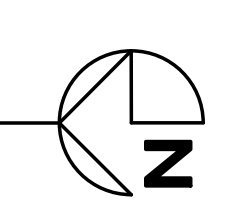

MAIN LEVEL FLOOR PLAN
 SCALE: 1/4" = 1'-0"



DATE PLOTTED: 2/23/2024 10:00:00 AM
 PLOTTER: HP DesignJet T1100e
 FILE: P:\Projects\2024\FUSED ELEMENTS\RESIDENCE (240426)\DWG\P2_20 FLOOR PLAN.DWG 08-08-2024 14:37

STORM DRAIN SIZING:
 STORM DRAIN PIPING SIZED PER 2018 UPC, CHAPTER 11, TABLES 1103.1 & 1103.2 FOR 1" PER HOUR RAINFALL RATE. HORIZONTAL PIPING SHALL BE SLOPED 1/8" PER LINEAR FOOT.

SIZE OF PIPE	MAXIMUM ALLOWABLE ROOF AREA (HORIZONTAL PIPING)	MAXIMUM ALLOWABLE ROOF AREA (VERTICAL PIPING)
3"	3,288 SF	8,800 SF
4"	7,520 SF	18,400 SF

- FLAG NOTES:**
-  HVAC EQUIPMENT (REF).
 -  CONDENSATE PUMP (REF). CONDENSATE PUMP PROVIDED BY MECHANICAL CONTRACTOR. PIPING BY PLUMBING CONTRACTOR.
 -  DISCHARGE 3/4" SECONDARY CONDENSATE DRAIN TO FLOOR.
 -  CONNECT 3/4" CONDENSATE DRAIN TO TAILPIECE OF LAVATORY. REFER TO DWG 4.00, DETAIL 8.

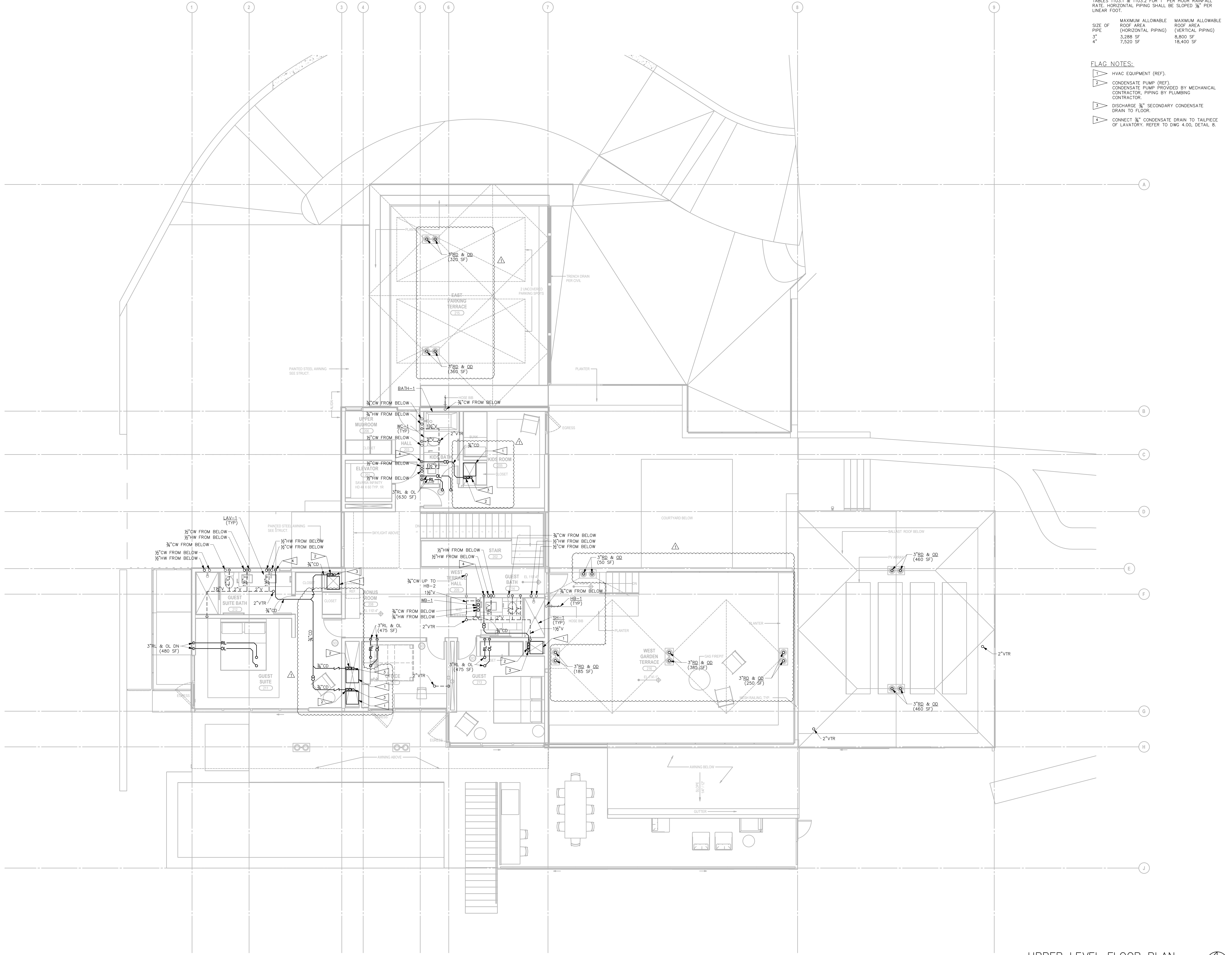

Olson Kundig
 project: FUSED ELEMENTS
 4525 FOREST AVE SE MERCER ISLAND WA 98040

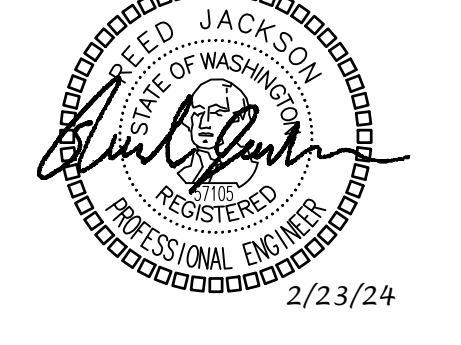

project architect: JMN
 project manager: JMN
 drawn by: JMN
 checked by: PR
 job no.: 1216-001

revisions:

1	2/23/24	PERMIT REVISION SET
---	---------	---------------------

no.: date: description:

NOT FOR CONSTRUCTION
 PERMIT SET
 2/23/2024

title:
UPPER LEVEL FLOOR PLAN

sheet:
P2.30

UPPER LEVEL FLOOR PLAN
 SCALE: 1/4" = 1'-0"

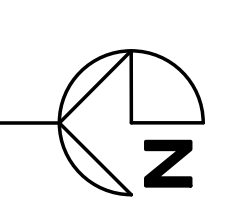

1/20/24 11:25 AM PROJECT: FUSED ELEMENTS RESIDENCE (24)KUN/OLSK/P2_30 FLOOR PLANS: 08-08-2023 14:37

STORM DRAIN SIZING:
 STORM DRAIN PIPING SIZED PER 2018 UPC, CHAPTER 11, TABLES 1103.1 & 1103.2 FOR 1" PER HOUR RAINFALL RATE. HORIZONTAL PIPING SHALL BE SLOPED 1/8" PER LINEAR FOOT.

SIZE OF PIPE	MAXIMUM ALLOWABLE ROOF AREA (HORIZONTAL PIPING)	MAXIMUM ALLOWABLE ROOF AREA (VERTICAL PIPING)
3"	3,288 SF	8,800 SF
4"	7,520 SF	18,400 SF

Olson Kundig
 PROJECT: FUSED ELEMENTS
 4525 FOREST AVE SE MERCER ISLAND WA 98040

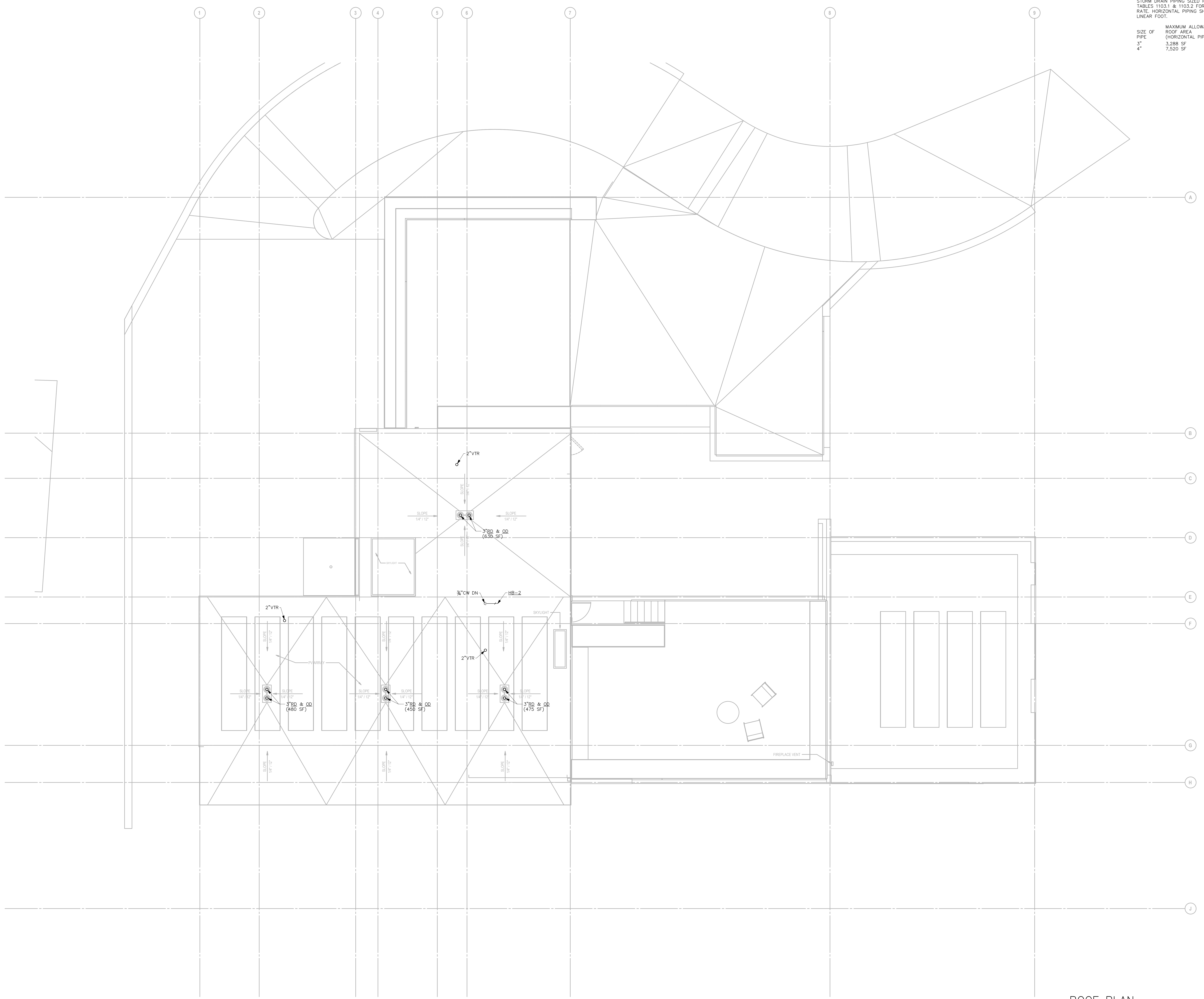
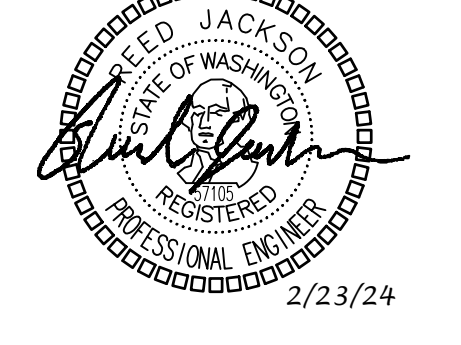
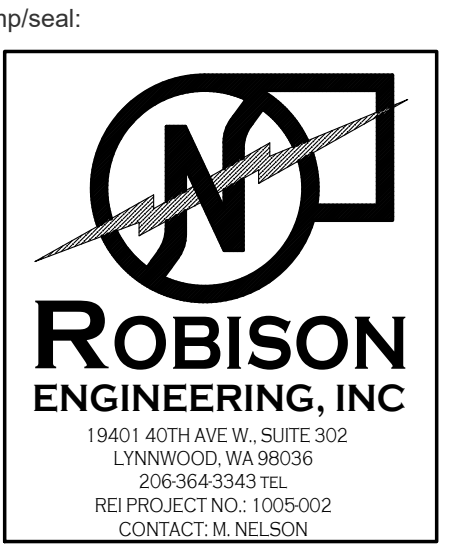

project architect: JMN
 project manager: JMN
 drawn by: JMN
 checked by: PR
 job no.: 1216-001

revisions:
 1 2/23/24 PERMIT REVISION SET

no.: date: description:

NOT FOR CONSTRUCTION
 PERMIT SET
 2/23/2024

title:
ROOF PLAN

sheet:
P2.40

ROOF PLAN
 SCALE: 1/4" = 1'-0"

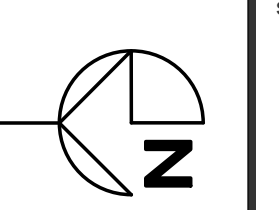

1/20/2024 12:12 PM ROBISON ENGINEERING, INC. (04426)0002_P2_00 FLOOR PLAN(S) 06-08-2023 14:37

NOTES:

- PIPE LENGTH & NUMBER OF FITTINGS TO INDIVIDUAL HEATERS SHALL BE EQUAL FOR A COMPLETE MANIFOLDED SELF-BALANCED PIPING.
- RELIEF DRAIN PIPING SHALL BE UNDIMINISHED IN SIZE (SAME AS OUTLET) AND SHALL TERMINATE AT 6" ABOVE FLOOR SINK AND SHALL BE IN COMPLIANCE WITH UPC.
- ANCHOR AND STRAP WATER HEATERS, EXPANSION TANK, AND STORAGE TANK TO RESIST HORIZONTAL DISPLACEMENT OF EARTHQUAKE PER CODE (COORD WITH STRUCTURAL).
- PROVIDE THERMAL EXPANSION TANK FOR WATER HEATERS PER CODE.

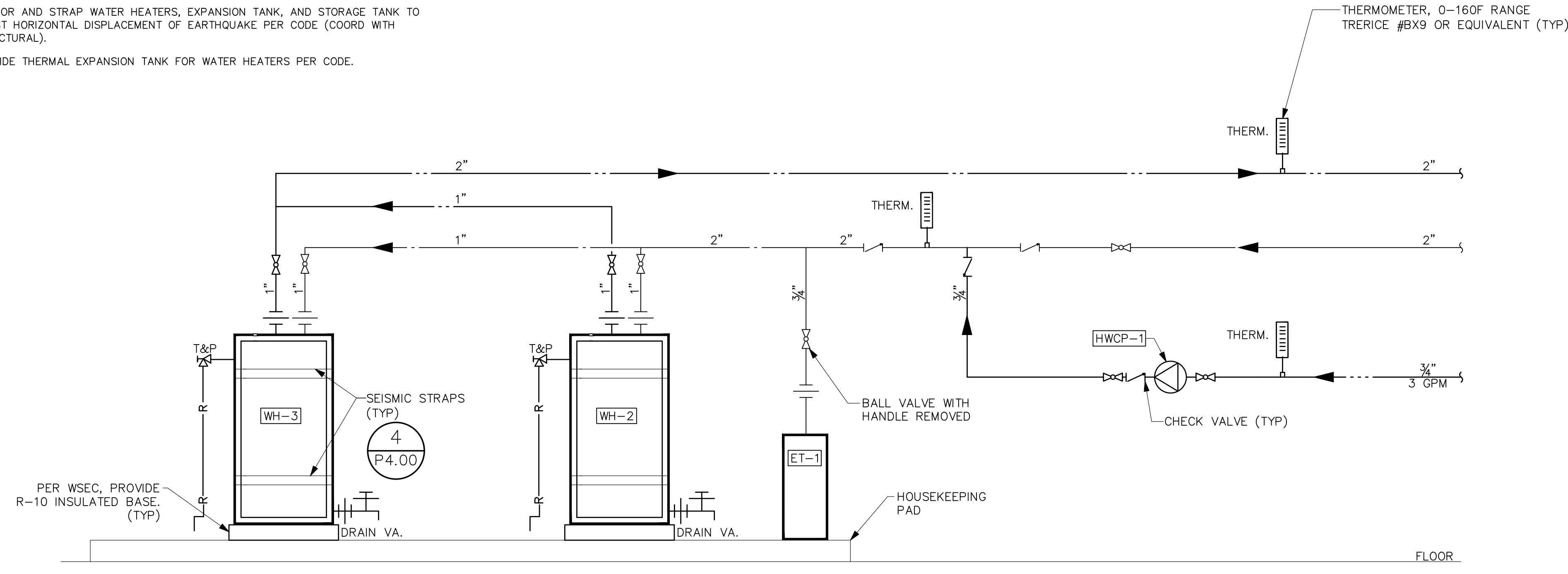

HEAT PUMP WATER HEATER PIPING

DIAGRAM

SCALE: NONE

10
P4.00

NOTES:

- LENGTH FROM METER TO FURTHEST APPLIANCE IS 275 FEET. GAS PIPING IS SIZED PER 2018 IFGC TABLE 402.4(2).
- PROVIDE CONNECTION TO EACH PIECE OF EQUIPMENT WITH DIRT LEG, UNION, AND GAS COCK(TYP).

NATURAL GAS PIPE SIZING TABLE 402.4(2)
LOW PRESSURE GAS (INLET PRESSURE < 2 PSI)

LENGTH (FT)	SCHEDULE 40 METALLIC PIPE						
	PIPE SIZE (IN.)						
	1/2	3/4	1	1-1/4	1-1/2	2	2-1/2
10	172	360	678	1,390	2,090	4,020	6,400
20	118	247	466	957	1,430	2,760	4,400
30	95	199	374	768	1,150	2,220	3,530
40	81	170	320	657	985	1,900	3,020
50	72	151	284	583	873	1,680	2,680
60	65	137	257	528	791	1,520	2,430
70	60	126	237	486	728	1,400	2,230
80	56	117	220	452	677	1,300	2,080
90	52	110	207	424	635	1,220	1,950
100	50	104	195	400	600	1,160	1,840
125	44	92	173	355	532	1,020	1,630
150	40	83	157	322	482	928	1,480
175	37	77	144	296	443	854	1,360
200	34	71	134	275	412	794	1,270
300	27	57	108	221	331	638	1,020

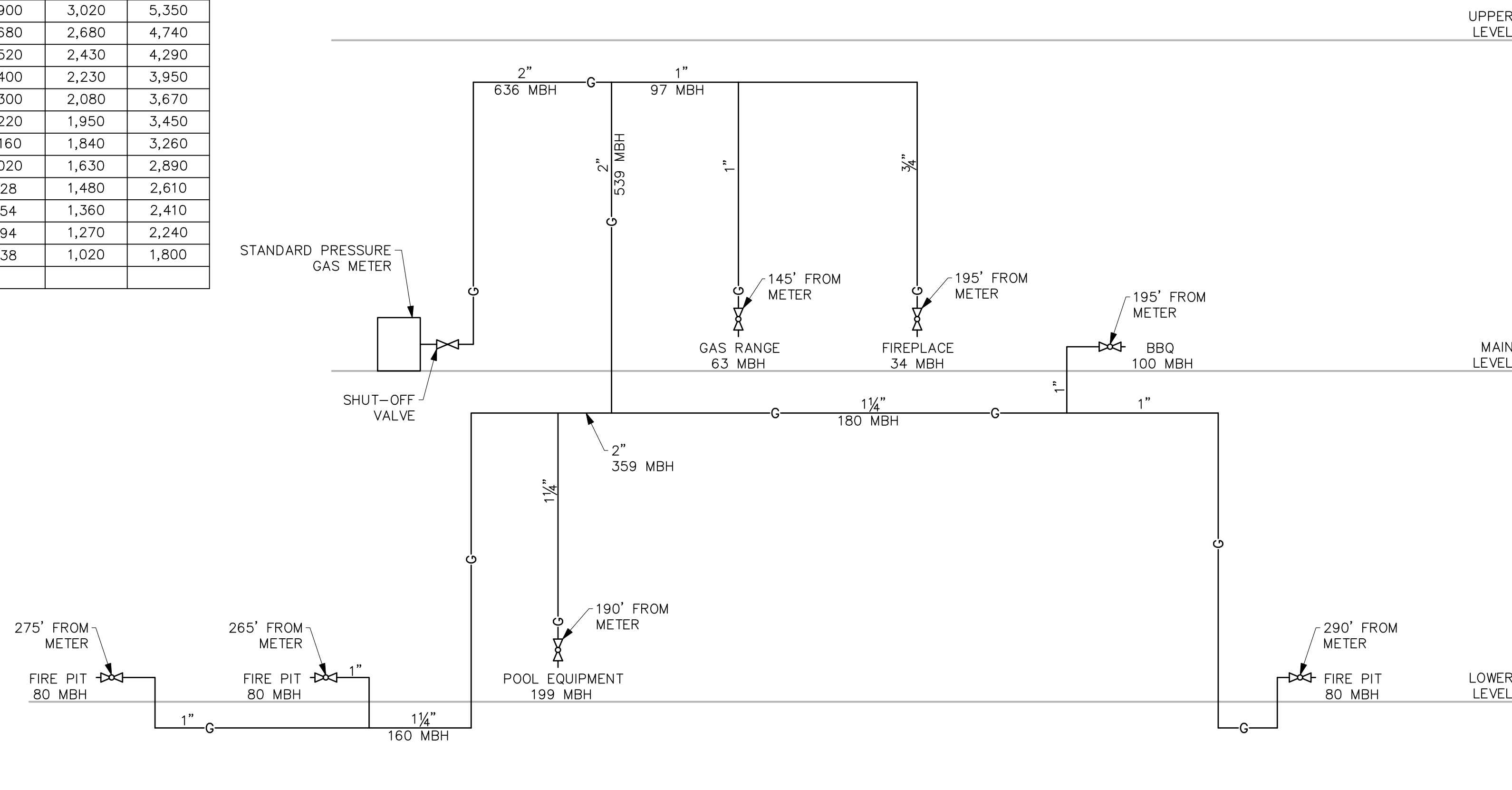

GAS PIPING RISER DIAGRAM

SCALE: NONE

11
P4.00

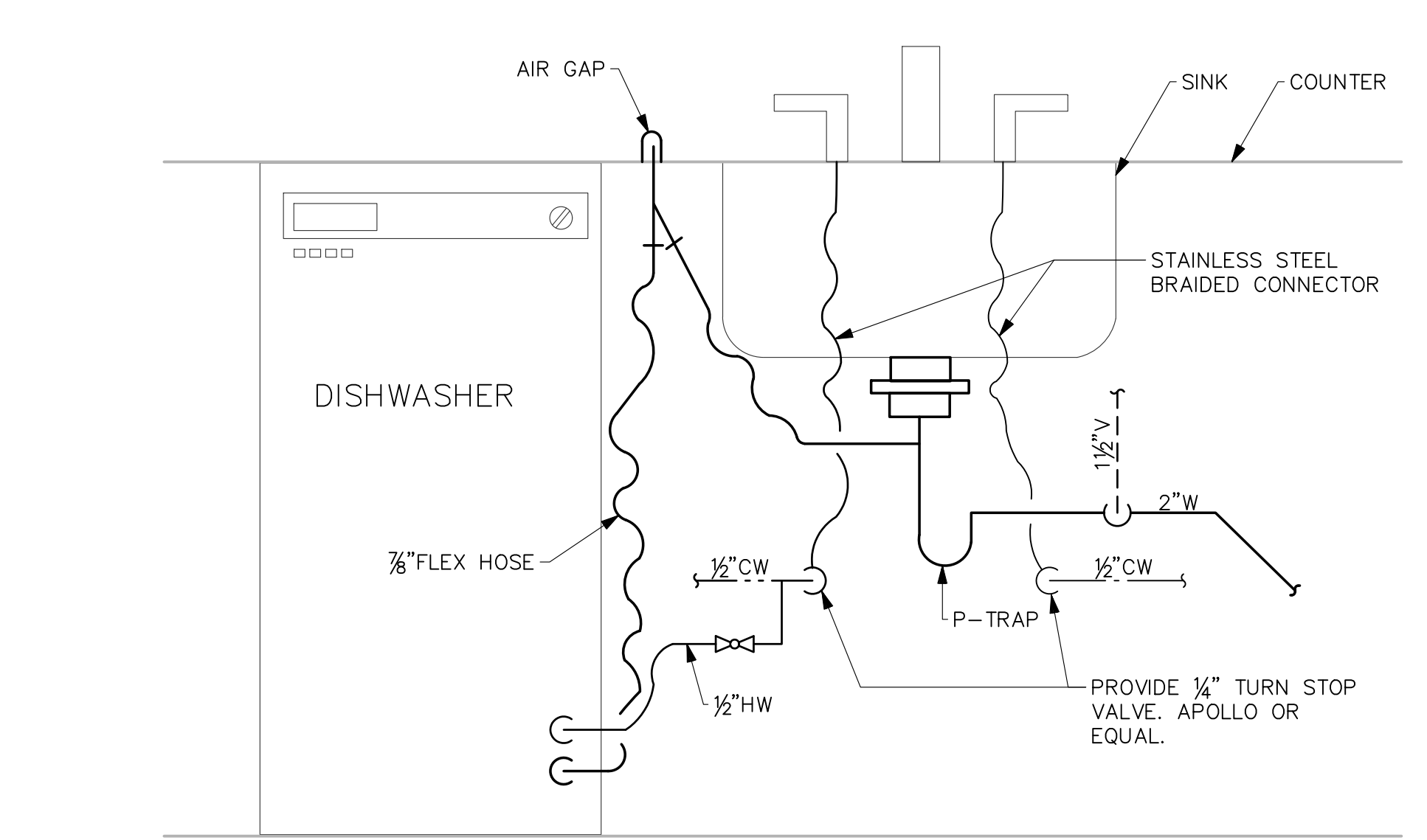

DISHWASHER CONNECTION

DETAIL

SCALE: NONE

5
P4.00

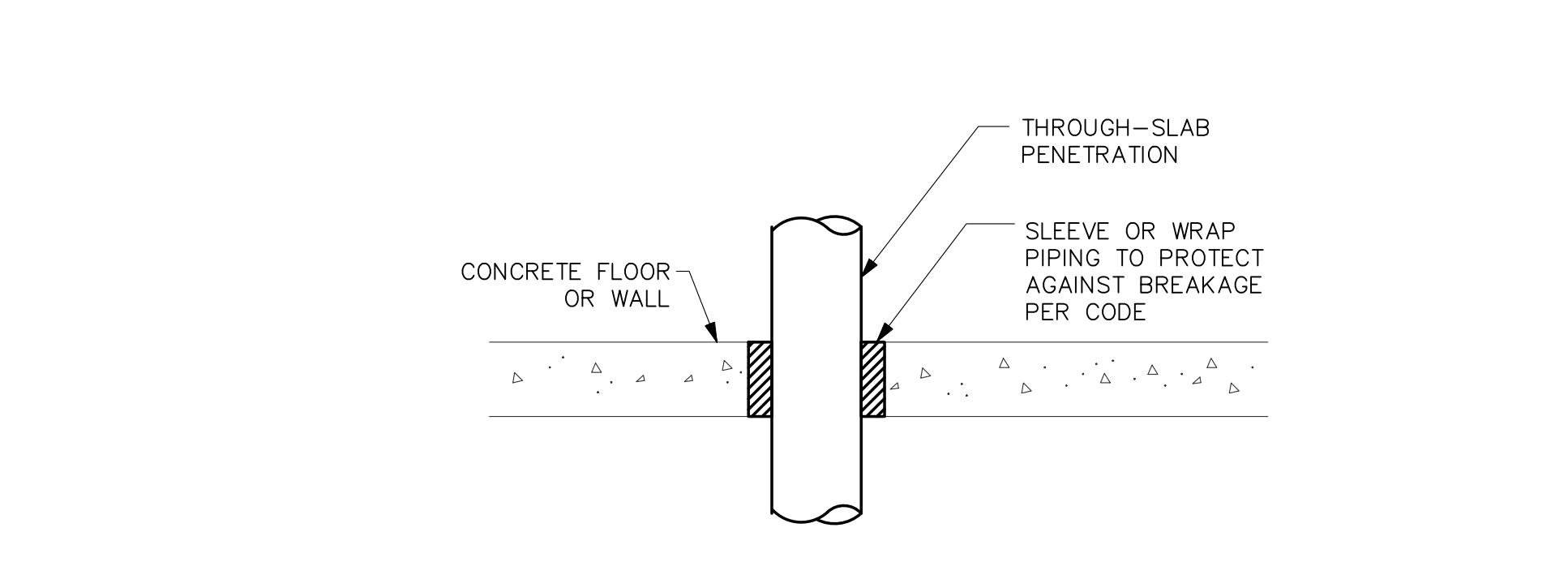

PIPE SLAB PENETRATION

DETAIL

SCALE: NONE

1
P4.00

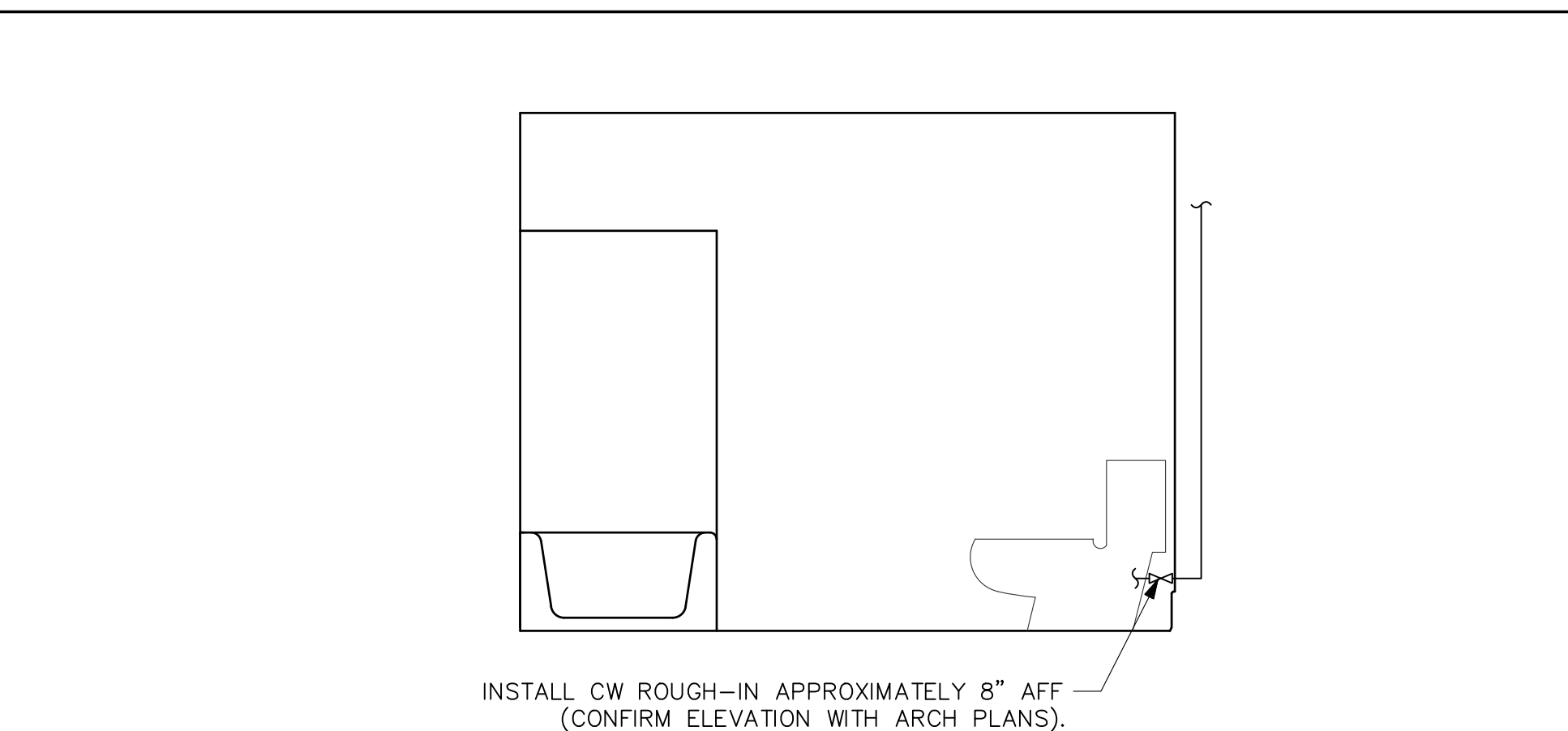

WATER CLOSET CW SUPPLY

DETAIL

SCALE: NONE

7
P4.00

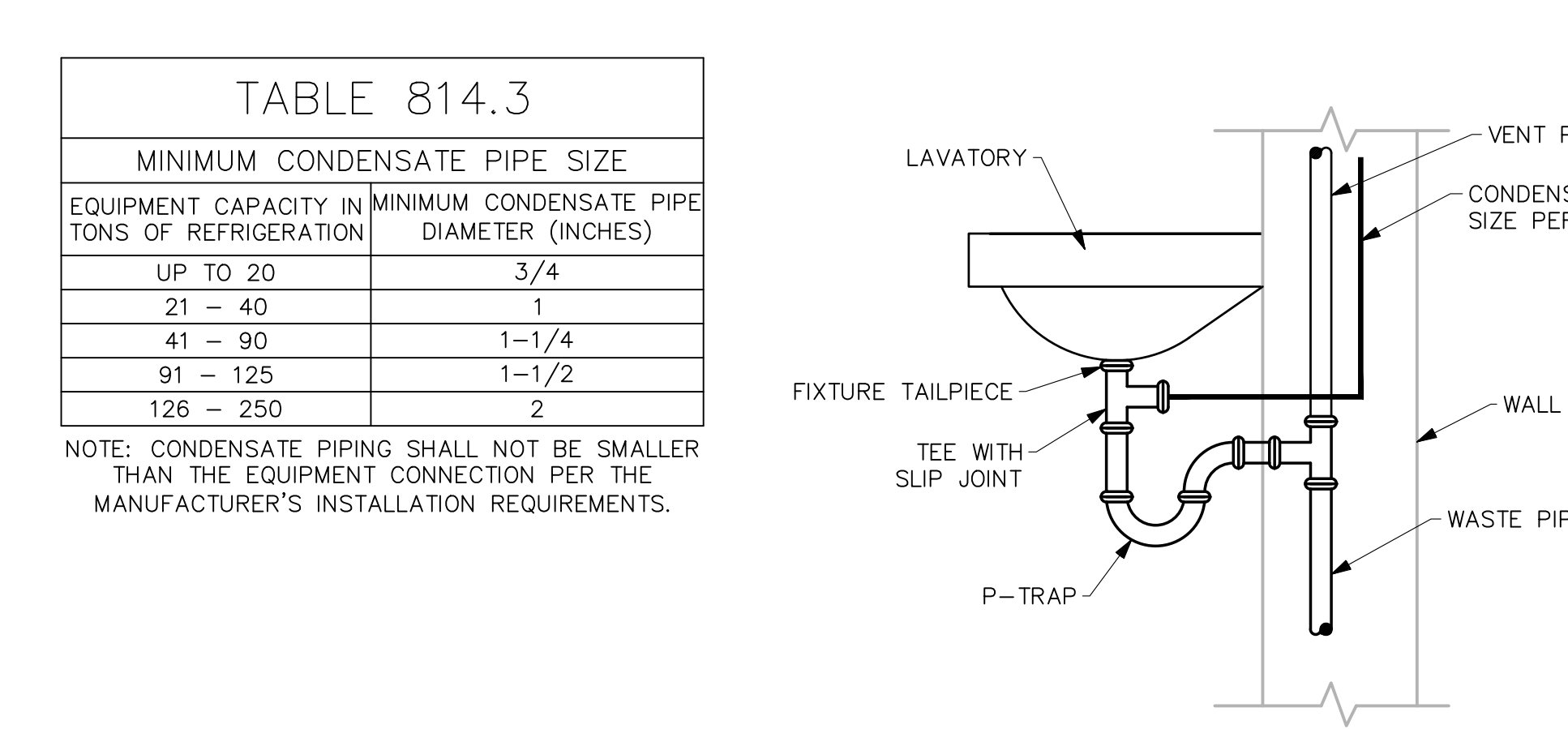

CONDENSATE TERMINATION

DETAIL

SCALE: NONE

8
P4.00

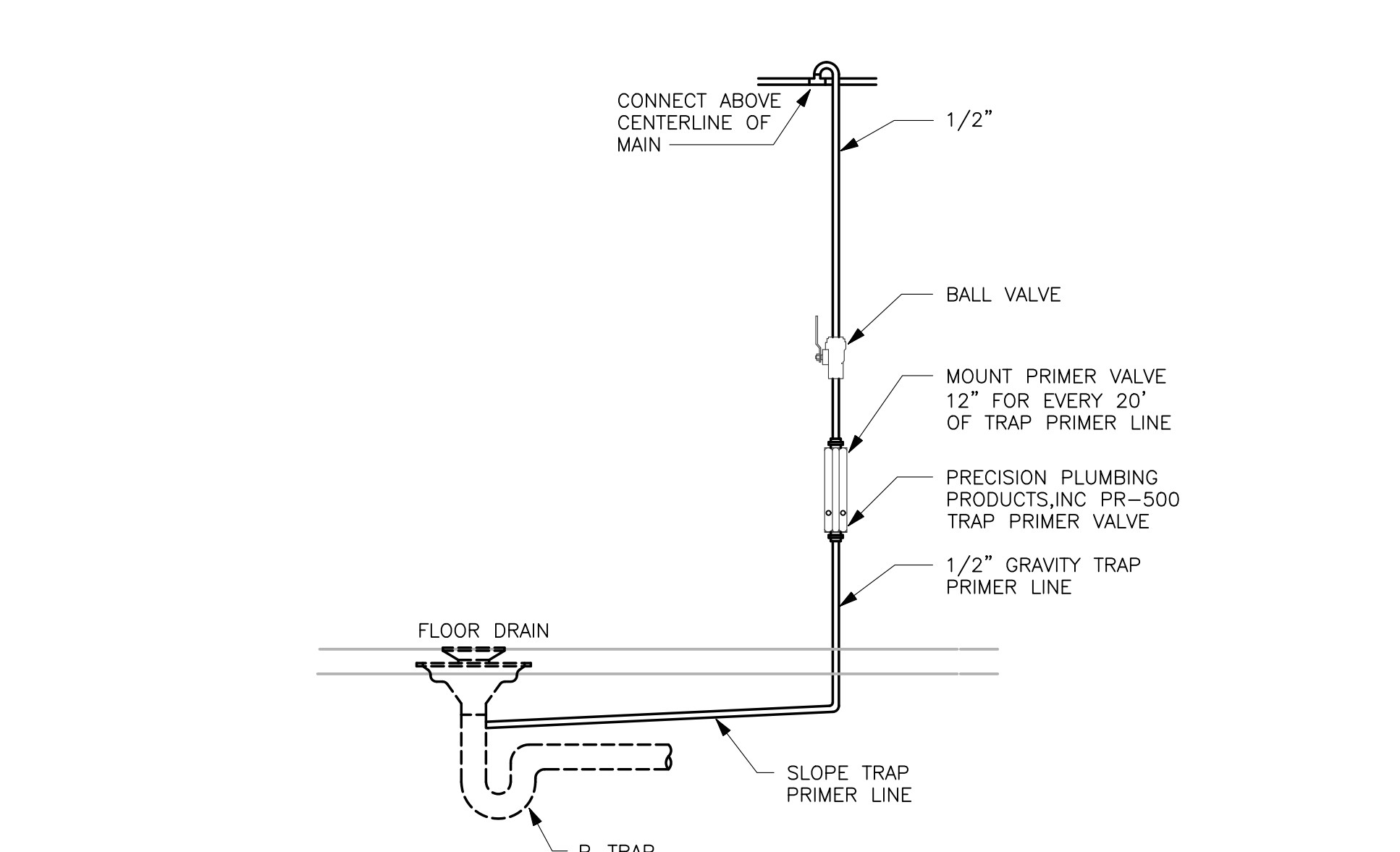

TRAP PRIMER

DETAIL

SCALE: NONE

9
P4.00

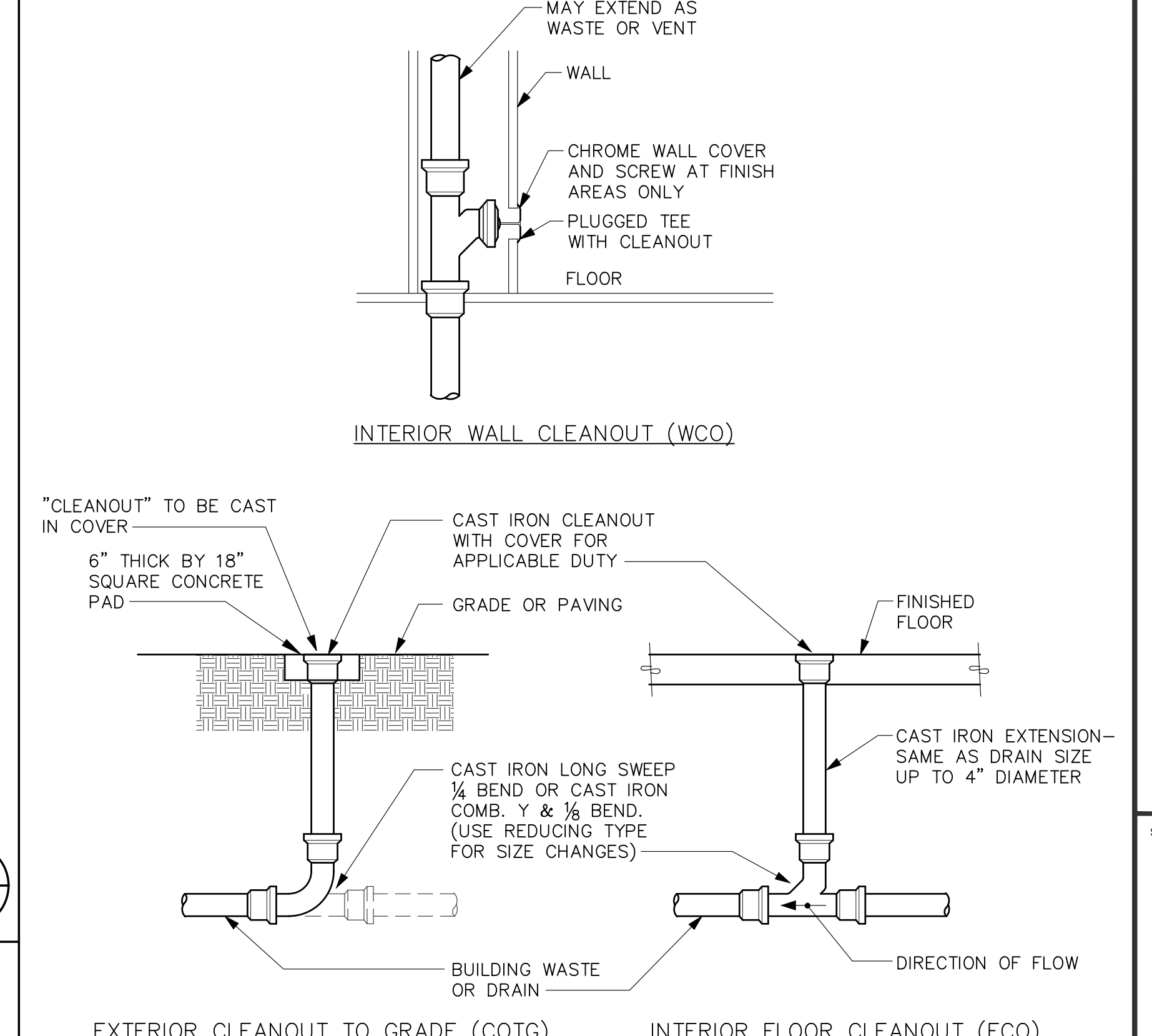

CLEANOUT

DETAIL

SCALE: NONE

1
P4.00

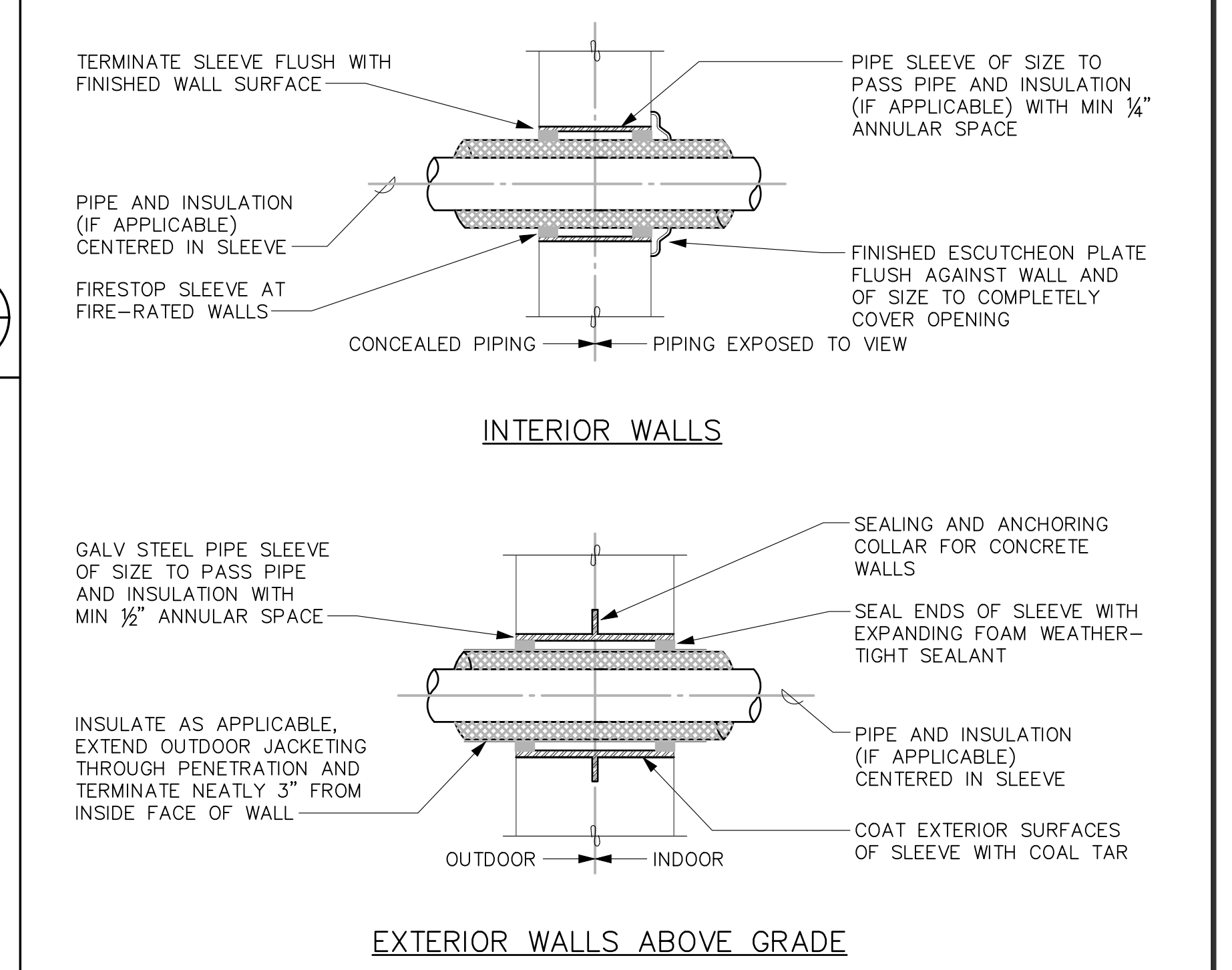

PIPE SLEEVES THROUGH WALLS

DETAIL

SCALE: NONE

2
P4.00

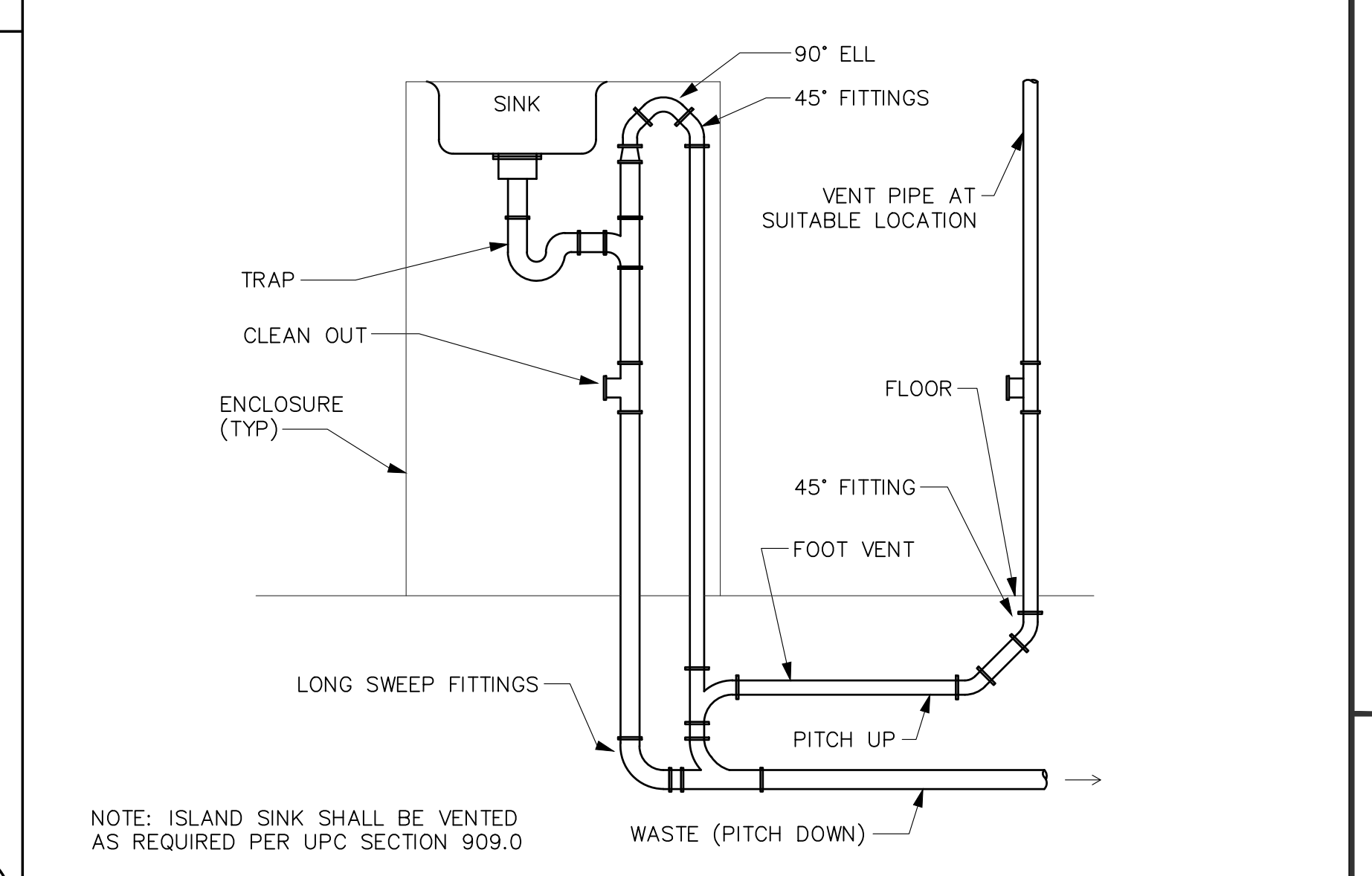

ISLAND SINK

DETAIL

SCALE: NONE

3
P4.00

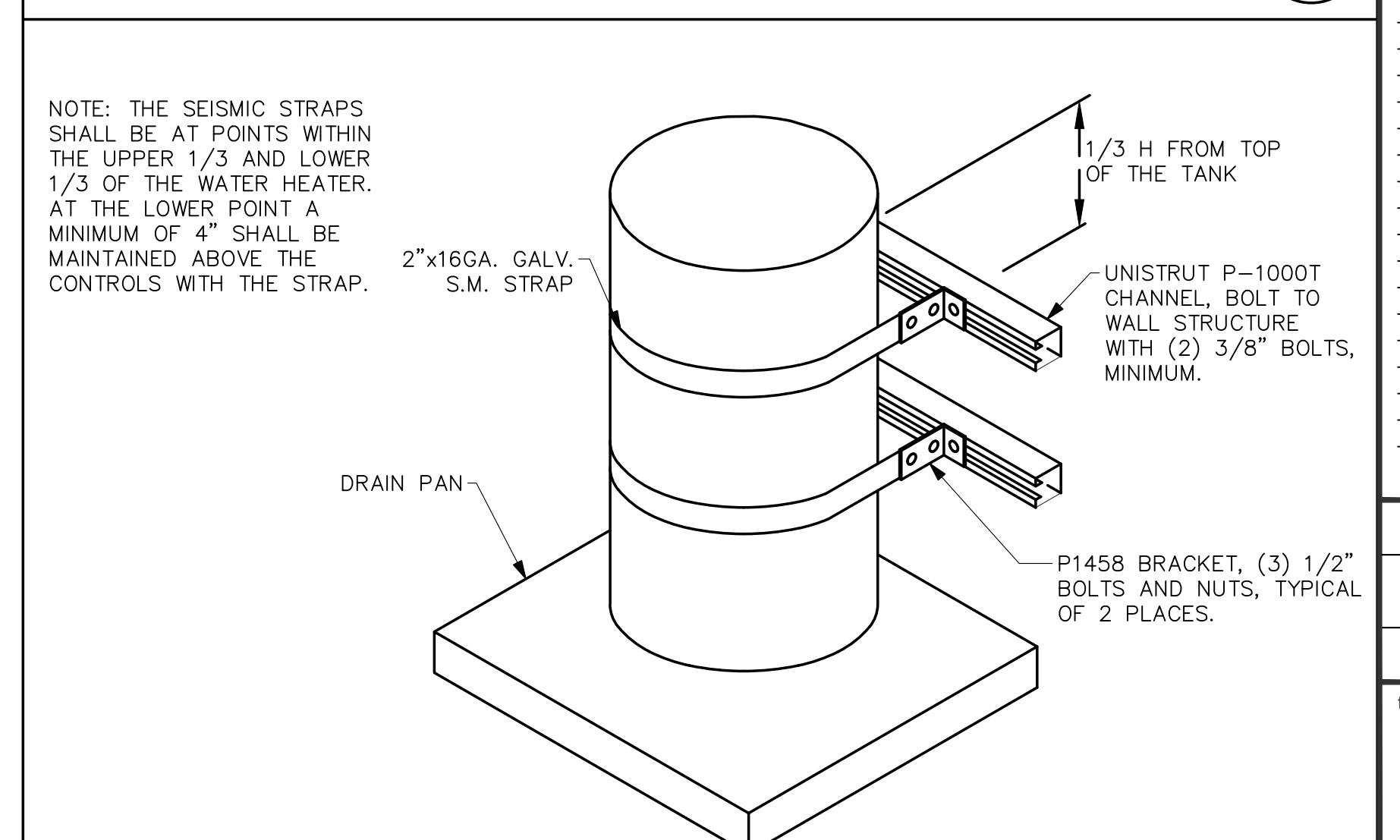

WATER HEATER SEISMIC STRAPPING

DETAIL

SCALE: NONE

4
P4.00

1555 Route 1, Suite 100
Seattle, Washington 98104 USA
Tel: 206.447.0000
Fax: 206.447.0001

Olson Kundig

Project: **FUSED ELEMENTS**
4525 FOREST AVE SE MERGER ISLAND WA 98040

stamp seal:
ROBISON ENGINEERING, INC.
18401 ACHASIE W. SUITE 300
LUMBERVILLE, MARYLAND
21084-5343 TEL:
410.766.7000 FAX:
410.766.7001

2/23/24

project architect: JMN
project manager: JMN
drawn by: JMN
checked by: PR
job no.: 1216-001

revisions:
1 2/23/24 PERMIT REVISION SET

no. date description:
NOT FOR CONSTRUCTION
PERMIT SET
2/23/2024

title: **DETAILS & DIAGRAMS**

sheet: **P4.00**



02/23/24

SYMBOLS	
GENERAL	LIGHT LINE INDICATES NON-ELECTRICAL OR BACKGROUND (THIS IS NOT CONTRACTUAL DEFINITION OF WORK) HEAVY LINE INDICATES NEW WORK (THIS IS NOT CONTRACTUAL DEFINITION OF WORK)
DETAIL IDENTIFICATION	
SYMBOL	NAME
	FLAG NOTE
	REVISION NOTE
	REVISION DEFINITION, AREA ENCIRCLED CONTAINS DRAWING CHANGES MADE SUBSEQUENT TO PREVIOUS ISSUE
LIGHTING	
	FIXTURE IDENTIFICATION SYMBOL (TYPE A, (2) 32 WATT LAMPS SHOWN) SEE SCHEDULE SEE LUMINAIRE SCHEDULE FOR FIXTURE SYMBOLS
SWITCHES	
	SWITCH, SINGLE POLE; WITH SWITCHING SUBSCRIPT
	OCCUPANCY SENSOR SWITCH, PROXIMITY INFRARED
	SWITCH, SINGLE POLE; WITH SWITCHING SUBSCRIPT "D" INDICATES WALLBOX DIMMER
	CEILING MOUNTED OCCUPANCY SENSOR
	CEILING MOUNTED AMBIENT LIGHT SENSOR
	WALL MOUNTED DUAL TECHNOLOGY OCCUPANT SENSOR
	SWITCH, TIMER.
	SWITCH, TWO POLE.
RECEPTACLES	
	SINGLE RECEPTACLE
	DUPLEX RECEPTACLE: WALL MOUNTED, +18" AFF
	CONTROLLED AND NON CONTROLLED DUPLEX RECEPTACLE (SPLIT WIRED RECEPTACLE)
	DUPLEX RECEPTACLE - ABOVE COUNTER
	DUPLEX GFCI ABOVE COUNTER
	DUPLEX GFCI
	DUPLEX GFCI WITH WEATHERPROOF COVER
	DUPLEX RECEPTACLE, WITH HEIGHT ABOVE FINISHED FLOOR INDICATED
	CEILING MOUNTED DUPLEX RECEPTACLE
	QUAD RECEPTACLE: WALL MOUNTED, +18" AFF
	FLOOR BOX ONE DUPLEX RECEPTACLE
	FLOOR BOX ONE DUPLEX RECEPTACLE + ONE DATA
	FLOOR BOX ONE DUPLEX RECEPTACLE + ONE DATA + ONE VOICE
	SPECIAL PURPOSE RECEPTACLE, AS NOTED
MISCELLANEOUS	
	JUNCTION BOX: 4SQ MOUNTED
	JUNCTION BOX: 4SQ WALL MOUNTED
	JUNCTION BOX: 4SQ TRACK
	CONNECTION FOR LIGHTED MIRROR COORDINATE LOCATION AND ELEVATION WITH ARCHITECT PRIOR TO ROUGH-IN
	THERMOSTAT
SIGNAL/COMMUNICATION	
	DATA OUTLET: WALL MOUNTED @ +18" AFF U.O.N.
	TELEPHONE/DATA OUTLET: WALL MOUNTED @ +18" AFF U.O.N.
	TELEVISION OUTLET: WALL MOUNTED @ +18" AFF U.O.N.
POWER	
	PANELBOARD
	NON-FUSED DISCONNECT SWITCH (WP = NEMA 3R WHERE APPROPRIATE)
	FUSED DISCONNECT SWITCH
	MOTOR CONNECTION (EQUIPMENT NAME, HORSEPOWER, VOLTAGE, AND PHASE INDICATED)
	EQUIPMENT CONNECTION (EQUIPMENT NAME, LOAD, VOLTAGE, AND PHASE INDICATED)
	TRANSFORMER, DRY TYPE, SHOWN TO SCALE
	KW METER AND BASE
PART OF THE DESIGN/BUILD FIRE ALARM SYSTEM	
	FIRE ALARM SYSTEM CONTROL PANEL
	FIRE ALARM SYSTEM PULL STATION
	FIRE ALARM SYSTEM STROBE/SPEAKER
	FIRE ALARM PHOTOELECTRIC SMOKE DETECTOR AND SPEAKER.
	FIRE ALARM COMBINATION PHOTOELECTRIC SMOKE DETECTOR, CARBON MONOXIDE DETECTOR, AND SPEAKER, GUESTROOM.
	FIXED HEAT DETECTOR
	CARBON MONOXIDE DETECTOR.
	ELECTRO-MAGNETIC DOOR HOLDER
	DUCT SMOKE DETECTOR

ABBREVIATIONS	
A	AMPERE
AC	ALTERNATING CURRENT, ABOVE COUNTER
AFF	ABOVE FINISHED FLOOR
AIC	AMPS INTERRUPTING CAPACITY
AL	ALUMINUM
AMP	AMPERE
AWG	AMERICAN WIRE GAUGE
BKR	BREAKER
BLDG	BUILDING
C	COIL OR CONDUIT
CKT	CIRCUIT
CO	CONDUIT/RACEWAY ONLY
CT	CURRENT TRANSFORMER
Cu	COPPER
CW	COOL WHITE
D	DIMMER
DED	DEDICATED
EC	ELECTRICAL CONTRACTOR
EF	EXHAUST FAN
ELEC	ELECTRICAL
EMT	ELECTRICAL METALLIC TUBING
EQUIP	EQUIPMENT
EXIST	EXISTING
FAA	FIRE ALARM ANNUNCIATOR
FACP	FIRE ALARM CONTROL PANEL
FLUOR	FLUORESCENT
GC	GENERAL CONTRACTOR
GFCI	GROUND FAULT CIRCUIT INTERRUPTER
GND	GROUND
GRS	GALVANIZED RIGID STEEL
HID	HIGH INTENSITY DISCHARGE
HP	HORSEPOWER
IG	ISOLATED GROUND
KCMIL	THOUSAND CIRCULAR MILLS
KVA	KILOVOLT AMPERES
KW	KILOWATT
LTG	LIGHTING
LV	LOW VOLTAGE
MFR	MANUFACTURER
MIN	MINIMUM
MLO	MAIN LUGS ONLY
N	NEUTRAL
NEC	NATIONAL ELECTRICAL CODE (NFPA-70)
NEMA	NATIONAL ELECTRICAL MANUFACTURERS ASSOCIATION
NTS	NOT TO SCALE
PANL	PANEL
POC	POINT OF CONNECTION
PT	POTENTIAL TRANSFORMER
PVC	POLYVINYL CHLORIDE
PWR	POWER
QTY	QUANTITY
RECEPT	RECEPTACLE
REF	REFERENCE
RI	ROUGH-IN
RM	ROOM
RO	RACEWAY ONLY
SHT	SHEET
SPEC	SPECIFICATIONS
SW	SWITCH
SWBD	SWITCHBOARD
SWGR	SWITCHGEAR
TYP	TYPICAL
UG	UNDERGROUND
UL	UNDERWRITERS LABORATORIES
UON	UNLESS OTHERWISE NOTED
V	VOLTS
W	WATTS
WW	WARM WHITE
WP	WEATHERPROOF
W/	WITH
W/O	WITHOUT
XFMR	TRANSFORMER
XFR	TRANSFER
Z	IMPEDANCE OR ZONE

GENERAL NOTES	
GENERAL	GENERAL
1.	PROVIDE ELECTRICAL INSTALLATION IN ACCORDANCE WITH THE GOVERNING ELECTRICAL CODE, LOCAL CODES, ORDINANCES AND REQUIREMENTS OF UTILITY COMPANIES FURNISHING SERVICES TO INSTALLATION.
2.	PROVIDE ALL WORK AND ITEMS NECESSARY FOR COMPLETE AND FUNCTIONAL ELECTRICAL SYSTEMS. THE ELECTRICAL DRAWINGS ARE DIAGRAMMATIC AND DO NOT NECESSARILY SHOW EVERY CONDUIT, BOX, CONDUCTOR OR SIMILAR ITEMS FOR A COMPLETE INSTALLATION.
3.	THE CONTRACTOR SHALL VISIT THE SITE PRIOR TO BID AND DETERMINE CONDITIONS WHICH MAY AFFECT BID. ANY ITEMS NOT FULLY UNDERSTOOD SHALL BE BROUGHT TO THE ATTENTION OF THE ARCHITECT PRIOR TO BIDDING.
4.	"REF" INDICATIONS DENOTE WORK COVERED ELSEWHERE (ARCHITECTURAL, STRUCTURAL, OR MECHANICAL).
5.	REFERENCE ARCHITECTURAL DRAWING FOR EXACT LOCATION OF DEVICES. QUESTIONS CONCERNING THE LOCATION OF DEVICES AND EQUIPMENT SHALL BE DIRECTED TO THE ARCHITECT. FAILURE TO COORDINATE REQUIREMENTS SHALL IN NO WAY RESULT IN ADDITIONAL COMPENSATION BEING PROVIDED TO THE CONTRACTOR.
6.	WHEREVER THE WORD "PROVIDE" IS USED, IT MEANS, "FURNISH AND INSTALL COMPLETE AND READY FOR USE."
7.	COORDINATE LOCATION OF ELECTRICAL WITH OTHER TRADES.
8.	REFER TO EQUIPMENT DRAWINGS FOR MECHANICAL CHARACTERISTICS (SIZE, LOCATION, ETC.) OF MECHANICAL EQUIPMENT, UNLESS OTHERWISE INDICATED. COORDINATE INSTALLATION AND LOCATION OF ALL EQUIPMENT WITH MECHANICAL CONTRACTOR. VERIFY ALL FUSE RATINGS, WIRE SIZES AND DISCONNECT SIZES PRIOR TO INSTALLATION.
	MATERIALS AND METHODS
1.	PROVIDE RACEWAY AND WIRING ROUTED CONCEALED WITHIN BUILDING STRUCTURE WHERE POSSIBLE. WHERE RACEWAY CANNOT BE CONCEALED, IT SHALL BE INSTALLED PER PROJECT MANAGER'S DIRECTION. ALL CONDUIT SHALL BE INSTALLED IN NEAT SYMMETRICAL LINES HORIZONTAL OR PERPENDICULAR TO BUILDING COLUMNS AND ROOF LINES. CONDUITS SHALL BE GROUPED ON COMMON SUPPORTS WHEREVER POSSIBLE.
2.	EXPOSED CONDUIT ROUTING: CONDUITS MAY BE ROUTED EXPOSED IN MECHANICAL AND ELECTRICAL ROOMS ONLY. EXPOSED CONDUITS SHALL BE SECURED A MINIMUM OF 6" ABOVE FLOOR.
3.	OUTDOOR EXPOSED CONDUIT ROUTING: CONDUITS ROUTED ON ROOF OR EXPOSED TO WEATHER SHALL BE GRC, PVC OR LIQUID-TIGHT FLEX. PROVIDE WATER-TIGHT CONNECTIONS AND FITTINGS.
4.	CLEARANCES: VERIFY PHYSICAL DIMENSIONS OF EQUIPMENT TO ENSURE THAT ACCESS CLEARANCES CAN BE MET.
5.	CONNECTIONS: PROVIDE GRS, METALLIC FLEX, OR LIQUIDTITE FLEX CONDUITS FOR CONNECTIONS TO MOTORS OR MOTORIZED EQUIPMENT.
6.	WIRING: PROVIDE MINIMUM #12 AWG WIRE SIZE. IF CONDUIT IS TO BE USED MINIMUM IS TO BE 1/2". FLEXIBLE CONDUIT AND FLEXIBLE CABLE IS PERMISSIBLE THROUGHOUT THE BUILDING.
	SITE ELECTRICAL
1.	TRENCHING: COORDINATE ALL TRENCHING WORK WITH OTHER UTILITY LOCATIONS AND DRAINAGE TRENCHES.
2.	UNDERGROUND CONDUITS: PROVIDE PVC, SCHEDULE 40, 3/4" MINIMUM. PROVIDE GRC CONDUIT TRANSITION ELBOW WHEN TURNING UP TO ABOVE GRADE.
3.	DIRECT-BURIED CONDUITS: CONDUIT FOR BRANCH CIRCUITS OUTSIDE BUILDINGS NOT BENEATH DRIVEWAYS OR PARKING AREAS SHALL BE DIRECTLY BURIED WITHOUT CONCRETE ENCASEMENT. THE DEPTH TO THE TOP OF BURIED CONDUITS SHALL BE 36". PROVIDE MARKER TAPE 12" BELOW GRADE.
4.	BELOW SLAB: CONDUIT ROUTED BELOW ON-GRADE FLOOR SLABS SHALL BE INSTALLED PRIOR TO FLOOR SLAB POUR. ROUTE CONDUITS BELOW SLAB AS STRAIGHT AS POSSIBLE TO MINIMIZE BENDS.
5.	ALL CONDUITS PENETRATING THE BUILDING ENVELOPE BELOW GRADE SHALL FOLLOW WATERPROOFING REQUIREMENTS IN THE ARCHITECTURAL DRAWINGS.
	NEUTRALS
1.	AT CONTRACTORS OPTION, NEUTRALS MAY BE SHARED ON COMBINED HOMERUNS UNLESS THE CIRCUIT HAS A GFCI BREAKER, AN ISOLATED GROUND, OR IS FROM A PANEL WITH TVSS PROTECTION. ANY NEUTRAL DOWNSTREAM FROM A DIMMER SHALL BE DEDICATED TO THE DIMMED LOAD.
2.	NEUTRAL WIRES SHOWN FOR TWO AND THREE POLE MECHANICAL AND KITCHEN EQUIPMENT MAY BE OMITTED UPON VERIFICATION THAT THEY ARE NOT REQUIRED EITHER FOR OPERATION OR CONTROL CIRCUITS PER MANUFACTURER'S SPECIFICATIONS.
	LIGHTING
1.	PROVIDE LIGHT FIXTURES WITH PROPER FITTING FLANGES, MOUNTING SUPPORTS, AND ACCESSORY ITEMS, UL LISTED FOR CONDITIONS OF USE.
	LOW VOLTAGE LIGHTING
1.	PROVIDE LOW VOLTAGE TRANSFORMERS IN NEARBY ACCESSIBLE CEILING SPACE.
2.	PROVIDE LOW VOLTAGE CONDUCTORS SIZED PER MANUFACTURER'S GUIDELINES TO MINIMIZE VOLTAGE DROP.
	LIGHTING CONTROL
1.	THE MAXIMUM LIGHTING POWER THAT MAY BE CONTROLLED FROM A SINGLE SWITCH OR AUTOMATIC CONTROL SHALL NOT EXCEED THAT WHICH IS PROVIDED BY A TWENTY AMPERE CIRCUIT LOADED TO NOT MORE THAN EIGHTY PERCENT. A MASTER CONTROL MAY BE INSTALLED PROVIDED THE INDIVIDUAL SWITCHES RETAIN THEIR CAPABILITY TO FUNCTION INDEPENDENTLY.
2.	EMERGENCY FIXTURES: EMERGENCY BATTERY/CHARGER SHALL BE CONNECTED TO AN UNSWITCHED LEG OF THE DESIGNATED CIRCUIT.

APPLICABLE CODES	
CODES:	
o	NATIONAL ELECTRICAL CODE 2020
o	COMPLY WITH LOCAL JURISDICTION REQUIREMENTS

DRAWING INDEX

DWG	DESCRIPTION	INCLUDED IN SET		SHEETS WITH REVISIONS	
		PERMIT SET 9/8/23	PERMIT REVISION SET 2/23/24	PERMIT REVISION SET 2/23/24	
E0.00	COVER SHEET, LEGEND AND NOTES	o	o		
E1.00	ELECTRICAL SITE PLAN	o	o		
E2.00	ELECTRICAL FLOOR PLANS	o	o	o	
E2.01	ELECTRICAL FLOOR PLANS	o	o	o	
E2.02	ELECTRICAL FLOOR PLANS	o	o		
E3.00	ONE-LINE DIAGRAM AND SCHEDULES	o	o		

GENERAL REQUIREMENTS

1. DRAWINGS ARE DIAGRAMMATIC, SHOWING THE GENERAL LOCATION, TYPE, LAYOUT, AND EQUIPMENT REQUIRED.
2. THE DRAWINGS SHALL NOT BE SCALED FOR EXACT MEASUREMENT.
3. REFER TO ARCHITECTURAL DRAWINGS FOR DIMENSIONS.
4. REFER TO MANUFACTURER'S STANDARD INSTALLATION DRAWINGS FOR EQUIPMENT CONNECTIONS AND INSTALLATION REQUIREMENTS.
5. PROVIDE DUCTWORK, CONNECTIONS, ACCESSORIES, OFFSETS, AND MATERIALS NECESSARY FOR A COMPLETE SYSTEM.

CONTRACTOR SUBSTITUTIONS & REVISIONS

1. PLEASE SUBMIT PROPOSALS FOR SUBSTITUTIONS OR REVISIONS FOR REVIEW AND APPROVAL PRIOR TO ORDERING MATERIAL OR DOING WORK.
2. FOR EQUIPMENT THAT IS SCHEDULED BY MANUFACTURER'S NAME AND CATALOG DESIGNATIONS, THE MANUFACTURER'S PUBLISHED DATA AND/OR SPECIFICATION FOR THAT ITEM ARE CONSIDERED PART OF SPECIFICATION.
3. ENGINEERING COSTS FOR REVISING MEP PLANS SHALL BE ADDRESSED IN THE COST ANALYSIS OF THE SUBSTITUTION PROPOSAL.
4. CONTRACTOR TO COORDINATE WITH ENGINEER AND DETERMINE ASSOCIATED DESIGN AND PERMITTING COSTS. CONTRACTOR SHALL BE RESPONSIBLE FOR OTHER COSTS ASSOCIATED WITH UNFORESEEN ISSUES RESULTING FROM SUBSTITUTIONS OR REVISIONS.

PRE-CON MEETING NOTES

CONTRACTORS SHALL ATTEND A PRE-CONSTRUCTION MEETING WITH THE ENGINEER FOR THE PURPOSE OF REVIEWING THE WORK PRIOR TO ORDERING ANY EQUIPMENT OR PERFORMING ANY WORK. THE MEETING SHALL BE LOCATED AT THE PROJECT SITE ON A DATE AND TIME TO BE MUTUALLY AGREED. THE MEETING WILL BE A WORKING SESSION. THE MEETING WILL BE FACILITATED BY THE ENGINEER AND THE AGENDA WILL INCLUDE A DETAILED REVIEW OF THE PLANS AND SPECIFICATIONS, CROSS CHECK WITH OTHER TRADES FOR COORDINATION ISSUES, REVIEW OF PROPOSED PRODUCTS, REVIEW OF PLANNED MEANS AND METHODS, AND ON-SITE INVESTIGATION OF FIELD CONDITIONS RELATIVE TO EXISTING CONDITIONS THAT COULD AFFECT THE WORK. PERSONS ATTENDING THE MEETING SHALL BE KNOWLEDGEABLE OF THE PROJECT AND SHALL BE THE SPECIFIC PERSONS INTENDED TO CONTINUE WITH THE PROJECT THROUGH TO COMPLETION. IF REQUIRED, REVISED PLANS WILL BE ISSUED THROUGH OFFICIAL CHANNELS. CHANGES IN THE BID PRICE WILL BE DISCUSSED, BUT NO CHANGE ORDERS WILL BE ISSUED UNLESS PROCESSED THROUGH OFFICIAL CHANNELS. IT SHALL BE UNDERSTOOD THAT THE ENGINEER HAS NO AUTHORITY TO ISSUE CHANGE ORDERS.

THE FOLLOWING TRADES SHALL BE REPRESENTED FOR THE MINIMUM TIME INDICATED:

MECHANICAL SHEET METAL	4 HOURS
PLUMBING/PIPING	4 HOURS
ELECTRICAL	4 HOURS
SPRINKLER	2 HOURS
GENERAL CONTRACTOR	ALL SESSIONS

project architect:	JAN
project manager:	JAN
drawn by:	HDA
checked by:	JR
job no.:	1216-001

revisions:	
no.:	date:
	description:

NOT FOR CONSTRUCTION	
PERMIT SET	
09/08/2023	
title:	ELECTRICAL LEGEND AND COVER SHEET
sheet:	E0.00

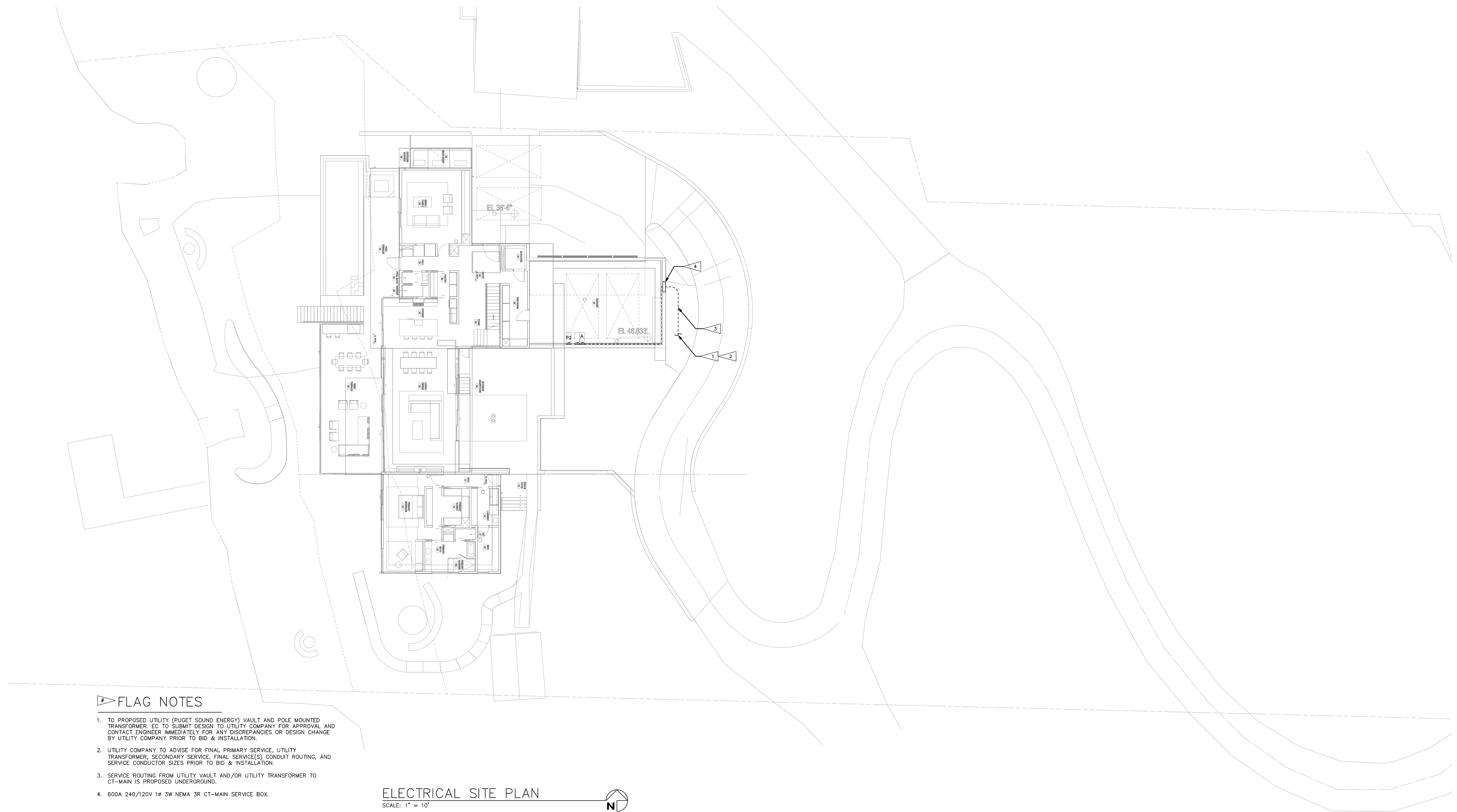

FLAG NOTES

1. TO PROPOSED UTILITY (PUGET SOUND ENERGY) VAULT AND POLE MOUNTED TRANSFORMER. EC TO SUBMIT DESIGN TO UTILITY COMPANY FOR APPROVAL AND CONTACT ENGINEER IMMEDIATELY FOR ANY DISCREPANCIES OR DESIGN CHANGE BY UTILITY COMPANY PRIOR TO BID & INSTALLATION.
2. UTILITY COMPANY TO ADVISE FOR FINAL PRIMARY SERVICE, UTILITY TRANSFORMER, SECONDARY SERVICE, FINAL SERVICE(S), CONDUIT ROUTING, AND SERVICE CONDUCTOR SIZES PRIOR TO BID & INSTALLATION.
3. SERVICE ROUTING FROM UTILITY VAULT AND/OR UTILITY TRANSFORMER TO CT-MAIN IS PROPOSED UNDERGROUND.
4. 600A 240/120V 1Ø 3W NEMA 3R CT-MAIN SERVICE BOX.

ELECTRICAL SITE PLAN

SCALE: 1" = 10'



Olson Kundig

project:
FUSED ELEMENTS
4525 FOREST AVE SE MERCER ISLAND WA 98040

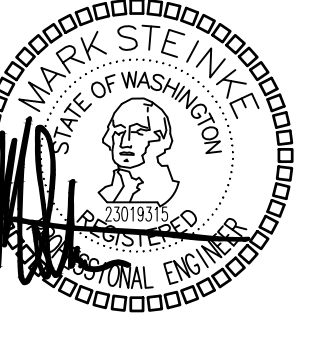

02/23/24

project architect: JAN
 project manager: JAN
 drawn by: HDA
 checked by: FR
 job no.: 1216-001

revisions:

no.	date	description

NOT FOR CONSTRUCTION
 PERMIT SET
 09/08/2023

title:
ELECTRICAL SITE PLAN

sheet:
E1.00

FLAG NOTES:

- 1 STUB 1" CONDUIT FROM PANEL INTO ATTIC SPACE FOR FUTURE SOLAR PV ARRAY.
- 2 VERIFY EXACT LOCATION FOR HEAT PUMP AND GFCI RECEPTACLE.
- 3 TWO RG6, TWO CAT6 OUTLETS.
- 4 ONE RG6 FOR CABLE TV, ONE CAT6 FOR WIRELESS ACCESS POINT CONNECTION.
- 5 STRUCTURED MEDIA PANEL. SIZE TO ACCOMMODATE CONTROL 4 OR EQUIVALENT WIRELESS ROUTER AND BAK PAK LITE.
- 6 PREWIRE AUDIO SPEAKER LOCATION BACK TO A/V CABINET LOCATION WITH #12 AUDIO CABLE RATED FOR IN-WALL INSTALLATION. TYP.
- 7 RING VIDEO DOOR BELL PRO ULTRA SLIM IN BLACK.
- 8 RUN RG6 UP TO ATTIC FOR FUTURE SATELLITE.
- 9 EC TO COORDINATE FINAL LOCATION WITH MECHANICAL DRAWINGS AND PROJECT MANAGER. SINGLE CIRCUIT APPLICATION OF HEATER REQUIRES SINGLE-POINT WIRING KIT ACCESSORY.
- 10 PROVIDE TAMPER RESISTANT RECEPTACLE.
- 11 BRILLIANT BRI 2-GANG SWITCH.
- 12 PROVIDE 5.1 PRECONFIGURED WALL PLATE FOR HOME THEATER SPEAKER RUNS TO TERMINATE. PROVIDE WIREHOME SPIO DISTRIBUTION PANEL(LOR SIMILAR) FOR UP TO TEN ROOMS TO BE TERMINATED AT THE A/V CABINET LOCATION. PROVIDE WALL MOUNTED IMPEDANCE MATCHING VOLUME CONTROL IN EACH ROOM EXCEPT HOME THEATER AREA.
- 13 PROVIDE IONIZATION SMOKE ALARM WITH AN ALARM SILENCER SWITCH.
- 14 COORDINATE EXACT LOCATION OF ENERGY RECOVERY VENTILATOR WITH MECHANICAL DRAWINGS & PROJECT MANAGER PRIOR TO INSTALLATION.
- 15 CAST JUNCTION BOX. EC TO FIELD DETERMINE FINAL LOCATION PRIOR TO BID AND INSTALLATION.
- 16 COORDINATE WITH CONSTRUCTION MANAGER, MANUFACTURER AND OWNER FOR GAS FIREPLACE POWER REQUIREMENTS AND SPECIFICATION. ADJUST WORK AS NECESSARY FOR A COMPLETE FUNCTIONING BUILD.
- 17 COORDINATE FINAL LOCATION OF ELEVATOR EQUIPMENT WITH PROJECT MANAGER PRIOR TO INSTALLATION.
- 18 INDOOR UNIT POWERED FROM OUTDOOR UNIT.
- 19 BRANCH BOX CONTROLLER POWERED FROM OUTDOOR HEAT PUMP UNIT. COORDINATE FINAL LOCATION WITH MECHANICAL DRAWING PRIOR TO INSTALLATION.
- 20 HEAT DETECTORS AND HEAT ALARMS SHALL BE CONNECTED TO AN ALARM OR A SMOKE ALARM THAT IS INSTALLED IN THE DWELLING. ALARMS AND SMOKE ALARMS THAT ARE INSTALLED FOR THIS PURPOSE SHALL BE LOCATED IN A HALLWAY, ROOM, OR OTHER LOCATION THAT WILL PROVIDE OCCUPANT NOTIFICATION.
- 21 COORDINATE EXACT LOCATION AND POWER REQUIREMENTS OF MOTORIZED SHADES POWER SUPPLY PER MANUFACTURER RECOMMENDATIONS AND PROJECT MANAGER PRIOR TO INSTALLATION.
- 22 PROVIDE RECESSED JUNCTION BOX AT THIS LOCATION. CIRCUIT THE JUNCTION BOX THROUGH THE LIGHTING CONTROL PANEL PER THE ZONE(S) NOTED ON THE PLANS FOR ON/OFF DIMMING CONTROL. COORDINATE FIXTURE TYPE AND REMOTE DRIVER LOCATION WITH LIGHTING DESIGN D. ARCHITECTURAL DRAWINGS AND PROJECT MANAGER.(TYPICAL)
- 23 COORDINATE FINAL LOCATION AND POWER REQUIREMENTS OF POOL EQUIPMENT PER MANUFACTURER RECOMMENDATIONS& PROJECT MANAGER PRIOR TO BID AND INSTALLATION.(TYPICAL)
- 24 PROVIDE EXHAUST FAN FOR CRAWL SPACE PER MECHANICAL DRAWING. COORDINATE EXACT LOCATION & POWER REQUIREMENTS PER MANUFACTURER RECOMMENDATION& PROJECT MANAGER PRIOR TO BID AND INSTALLATION.

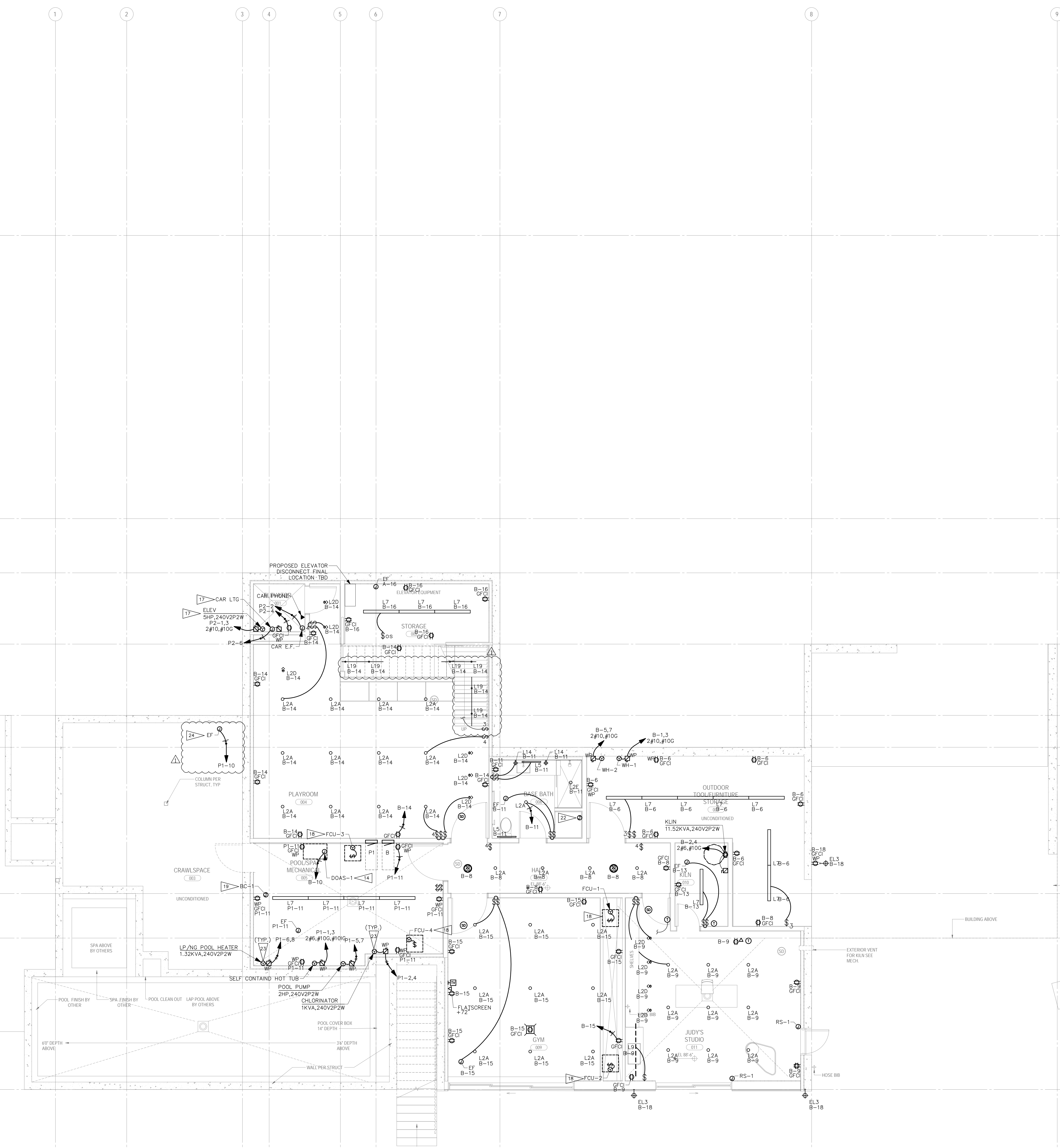

LOWER LEVEL FLOOR
ELECTRICAL PLAN
SCALE: 1/4" = 1'-0"

10750 North Jackson St, Suite 100
Seattle, Washington 98148 USA
P: 206 425 4311
F: 206 425 4312
www.olsonkundig.com

Olson Kundig

project: **FUSED ELEMENTS**
4525 FOREST AVE SE, MERCER ISLAND, WA 98040

stamp seal:

02/23/24

project architect: JMN	project manager: JMN
drawn by: HDA	checked by: PR
job no.: 1216-001	

revisions:	no.:	date:	description:

NOT FOR CONSTRUCTION
PERMIT SET
09/08/2023

title:	ELECTRICAL FLOOR PLANS
--------	---------------------------

sheet:	E2.00
--------	--------------

FLAG NOTES:

- 1 STUB 1" CONDUIT FROM PANEL INTO ATTIC SPACE FOR FUTURE SOLAR PV ARRAY.
- 2 VERIFY EXACT LOCATION FOR HEAT PUMP AND GFCI RECEPTACLE.
- 3 TWO RG6, TWO CAT6 OUTLETS.
- 4 ONE RG6 FOR CABLE TV, ONE CAT6 FOR WIRELESS ACCESS POINT CONNECTION.
- 5 STRUCTURED MEDIA PANEL, SIZE TO ACCOMMODATE CONTROL 4 OR EQUIVALENT WIRELESS ROUTER AND BAK PAK LITE.
- 6 PREWIRE AUDIO SPEAKER LOCATION BACK TO A/V CABINET LOCATION WITH #12 AUDIO CABLE RATED FOR IN-WALL INSTALLATION, TYP.
- 7 RING VIDEO DOOR BELL PRO ULTRA SLIM IN BLACK.
- 8 RUN RG6 UP TO ATTIC FOR FUTURE SATELLITE.
- 9 EC TO COORDINATE FINAL LOCATION WITH MECHANICAL DRAWINGS AND PROJECT MANAGER. SINGLE CIRCUIT APPLICATION OF HEATER REQUIRES SINGLE-POINT WIRING KIT ACCESSORY.
- 10 PROVIDE TAMPER RESISTANT RECEPTACLE.
- 11 BRILLIANT BRI 2-GANG SWITCH.
- 12 PROVIDE 5.1 PRECONFIGURED WALL PLATE FOR HOME THEATER SPEAKER RUNS TO TERMINATE. PROVIDE WIREHOME SPIO DISTRIBUTION PANEL (OR SIMILAR) FOR UP TO TEN ROOMS TO BE TERMINATED AT THE A/V CABINET LOCATION. PROVIDE WALL MOUNTED IMPEDANCE MATCHING VOLUME CONTROL IN EACH ROOM EXCEPT HOME THEATER AREA.
- 13 PROVIDE IONIZATION SMOKE ALARM WITH AN ALARM SILENCER SWITCH.
- 14 COORDINATE EXACT LOCATION OF ENERGY RECOVERY VENTILATOR WITH MECHANICAL DRAWINGS & PROJECT MANAGER PRIOR TO INSTALLATION.
- 15 CAST JUNCTION BOX, EC TO FIELD DETERMINE FINAL LOCATION PRIOR TO BID AND INSTALLATION.
- 16 COORDINATE WITH CONSTRUCTION MANAGER, MANUFACTURER AND OWNER FOR GAS FIREPLACE POWER REQUIREMENTS AND SPECIFICATION. ADJUST WORK AS NECESSARY FOR A COMPLETE FUNCTIONING BUILD.
- 17 COORDINATE FINAL LOCATION OF ELEVATOR EQUIPMENT WITH PROJECT MANAGER PRIOR TO INSTALLATION.
- 18 INDOOR UNIT POWERED FROM OUTDOOR UNIT.
- 19 BRANCH BOX CONTROLLER POWERED FROM OUTDOOR HEAT PUMP UNIT. COORDINATE FINAL LOCATION WITH MECHANICAL DRAWING PRIOR TO INSTALLATION.
- 20 HEAT DETECTORS AND HEAT ALARMS SHALL BE CONNECTED TO AN ALARM OR A SMOKE ALARM THAT IS INSTALLED IN THE DWELLING. ALARMS AND SMOKE ALARMS THAT ARE INSTALLED FOR THIS PURPOSE SHALL BE LOCATED IN A HALLWAY, ROOM, OR OTHER LOCATION THAT WILL PROVIDE OCCUPANT NOTIFICATION.
- 21 COORDINATE EXACT LOCATION AND POWER REQUIREMENTS OF MOTORIZED SHADES POWER SUPPLY PER MANUFACTURER RECOMMENDATIONS AND PROJECT MANAGER PRIOR TO INSTALLATION.
- 22 PROVIDE RECESSED JUNCTION BOX AT THIS LOCATION. CIRCUIT THE JUNCTION BOX THROUGH THE LIGHTING CONTROL PANEL PER THE ZONE(S) NOTED ON THE PLANS FOR ON/OFF DIMMING CONTROL. COORDINATE FIXTURE TYPE AND REMOTE DRIVER LOCATION WITH LIGHTING DESIGN D, ARCHITECTURAL DRAWINGS AND PROJECT MANAGER (TYPICAL).
- 23 COORDINATE FINAL LOCATION AND POWER REQUIREMENTS OF POOL EQUIPMENT PER MANUFACTURER RECOMMENDATIONS & PROJECT MANAGER PRIOR TO BID AND INSTALLATION (TYPICAL).
- 24 PROVIDE EXHAUST FAN FOR CRAWL SPACE PER MECHANICAL DRAWING. COORDINATE EXACT LOCATION & POWER REQUIREMENTS PER MANUFACTURER RECOMMENDATION & PROJECT MANAGER PRIOR TO BID AND INSTALLATION.

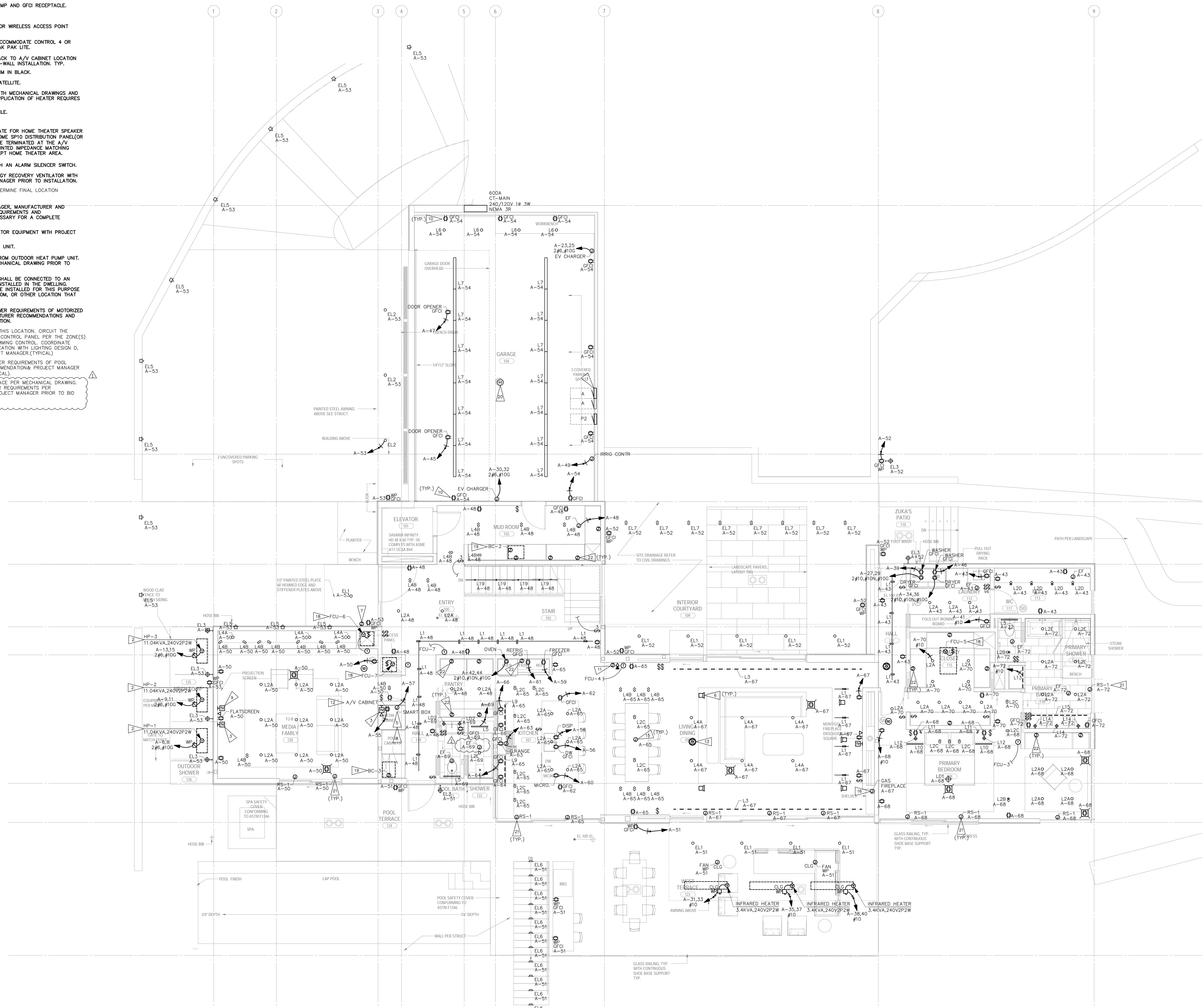

**MAIN LEVEL FLOOR
ELECTRICAL PLAN**
SCALE: 1/4" = 1'-0"

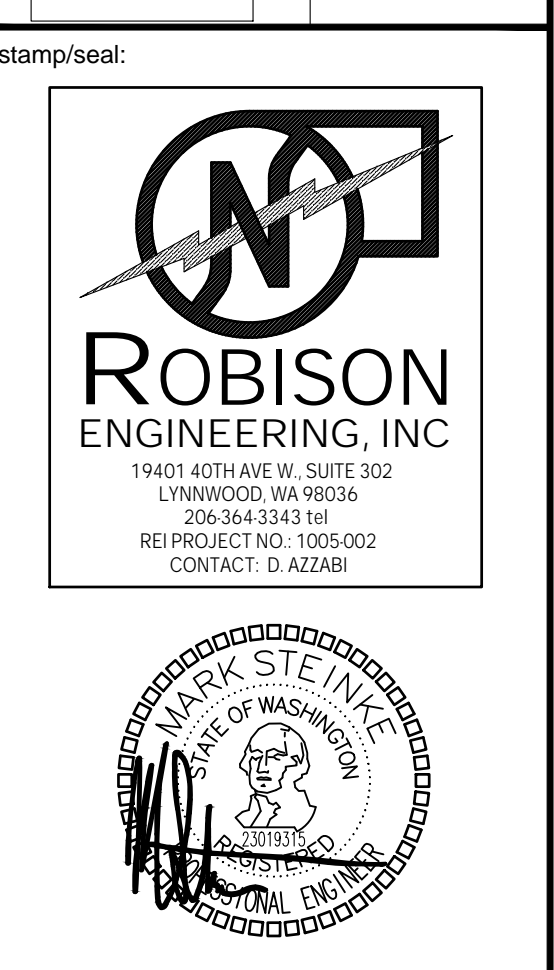

02/23/24

project architect:	JAN
project manager:	JAN
drawn by:	HDA
checked by:	PR
job no.:	1216-001
revisions:	
no.:	description:

FLAG NOTES:

- 1 ▸ STUB 1" CONDUIT FROM PANEL INTO ATTIC SPACE FOR FUTURE SOLAR PV ARRAY.
- 2 ▸ VERIFY EXACT LOCATION FOR HEAT PUMP AND GFCI RECEPTACLE.
- 3 ▸ TWO RG6, TWO CAT6 OUTLETS.
- 4 ▸ ONE RG6 FOR CABLE TV, ONE CAT6 FOR WIRELESS ACCESS POINT CONNECTION.
- 5 ▸ STRUCTURED MEDIA PANEL. SIZE TO ACCOMMODATE CONTROL 4 OR EQUIVALENT WIRELESS ROUTER AND BAK PAK LITE.
- 6 ▸ PREWIRE AUDIO SPEAKER LOCATION BACK TO A/V CABINET LOCATION WITH #12 AUDIO CABLE RATED FOR IN-WALL INSTALLATION, TYP.
- 7 ▸ RING VIDEO DOOR BELL PRO ULTRA SLIM IN BLACK.
- 8 ▸ RUN RG6 UP TO ATTIC FOR FUTURE SATELLITE.
- 9 ▸ EC TO COORDINATE FINAL LOCATION WITH MECHANICAL DRAWINGS AND PROJECT MANAGER. SINGLE CIRCUIT APPLICATION OF HEATER REQUIRES SINGLE-POINT WIRING KIT ACCESSORY.
- 10 ▸ PROVIDE TAMPER RESISTANT RECEPTACLE.
- 11 ▸ BRILLIANT BRI 2-GANG SWITCH.
- 12 ▸ PROVIDE 5.1 PRECONFIGURED WALL PLATE FOR HOME THEATER SPEAKER RUNS TO TERMINATE. PROVIDE WIREHOME SP10 DISTRIBUTION PANEL (OR SIMILAR) FOR UP TO TEN ROOMS TO BE TERMINATED AT THE A/V CABINET LOCATION. PROVIDE WALL MOUNTED IMPEDANCE MATCHING VOLUME CONTROL IN EACH ROOM EXCEPT HOME THEATER AREA.
- 13 ▸ PROVIDE IONIZATION SMOKE ALARM WITH AN ALARM SILENCER SWITCH.
- 14 ▸ COORDINATE EXACT LOCATION OF ENERGY RECOVERY VENTILATOR WITH MECHANICAL DRAWINGS & PROJECT MANAGER PRIOR TO INSTALLATION.
- 15 ▸ CAST JUNCTION BOX. EC TO FIELD DETERMINE FINAL LOCATION PRIOR TO BID AND INSTALLATION.
- 16 ▸ COORDINATE WITH CONSTRUCTION MANAGER, MANUFACTURER AND OWNER FOR GAS FIREPLACE POWER REQUIREMENTS AND SPECIFICATION. ADJUST WORK AS NECESSARY FOR A COMPLETE FUNCTIONING BUILD.
- 17 ▸ COORDINATE FINAL LOCATION OF ELEVATOR EQUIPMENT WITH PROJECT MANAGER PRIOR TO INSTALLATION.
- 18 ▸ INDOOR UNIT POWERED FROM OUTDOOR UNIT.
- 19 ▸ BRANCH BOX CONTROLLER POWERED FROM OUTDOOR HEAT PUMP UNIT. COORDINATE FINAL LOCATION WITH MECHANICAL DRAWING PRIOR TO INSTALLATION.
- 20 ▸ HEAT DETECTORS AND HEAT ALARMS SHALL BE CONNECTED TO AN ALARM OR A SMOKE ALARM THAT IS INSTALLED IN THE DWELLING. ALARMS AND SMOKE ALARMS THAT ARE INSTALLED FOR THIS PURPOSE SHALL BE LOCATED IN A HALLWAY, ROOM, OR OTHER LOCATION THAT WILL PROVIDE OCCUPANT NOTIFICATION.
- 21 ▸ COORDINATE EXACT LOCATION AND POWER REQUIREMENTS OF MOTORIZED SHADES POWER SUPPLY PER MANUFACTURER RECOMMENDATIONS AND PROJECT MANAGER PRIOR TO INSTALLATION.
- 22 ▸ PROVIDE RECESSED JUNCTION BOX AT THIS LOCATION. CIRCUIT THE JUNCTION BOX THROUGH THE LIGHTING CONTROL PANEL PER THE ZONE(S) NOTED ON THE PLANS FOR ON/OFF DIMMING CONTROL. COORDINATE FIXTURE TYPE AND REMOTE DRIVER LOCATION WITH LIGHTING DESIGN D. ARCHITECTURAL DRAWINGS AND PROJECT MANAGER (TYPICAL).
- 23 ▸ COORDINATE FINAL LOCATION AND POWER REQUIREMENTS OF POOL EQUIPMENT PER MANUFACTURER RECOMMENDATIONS & PROJECT MANAGER PRIOR TO BID AND INSTALLATION (TYPICAL).
- 24 ▸ PROVIDE EXHAUST FAN FOR CRAWL SPACE PER MECHANICAL DRAWING. COORDINATE EXACT LOCATION & POWER REQUIREMENTS PER MANUFACTURER RECOMMENDATIONS & PROJECT MANAGER PRIOR TO BID AND INSTALLATION.

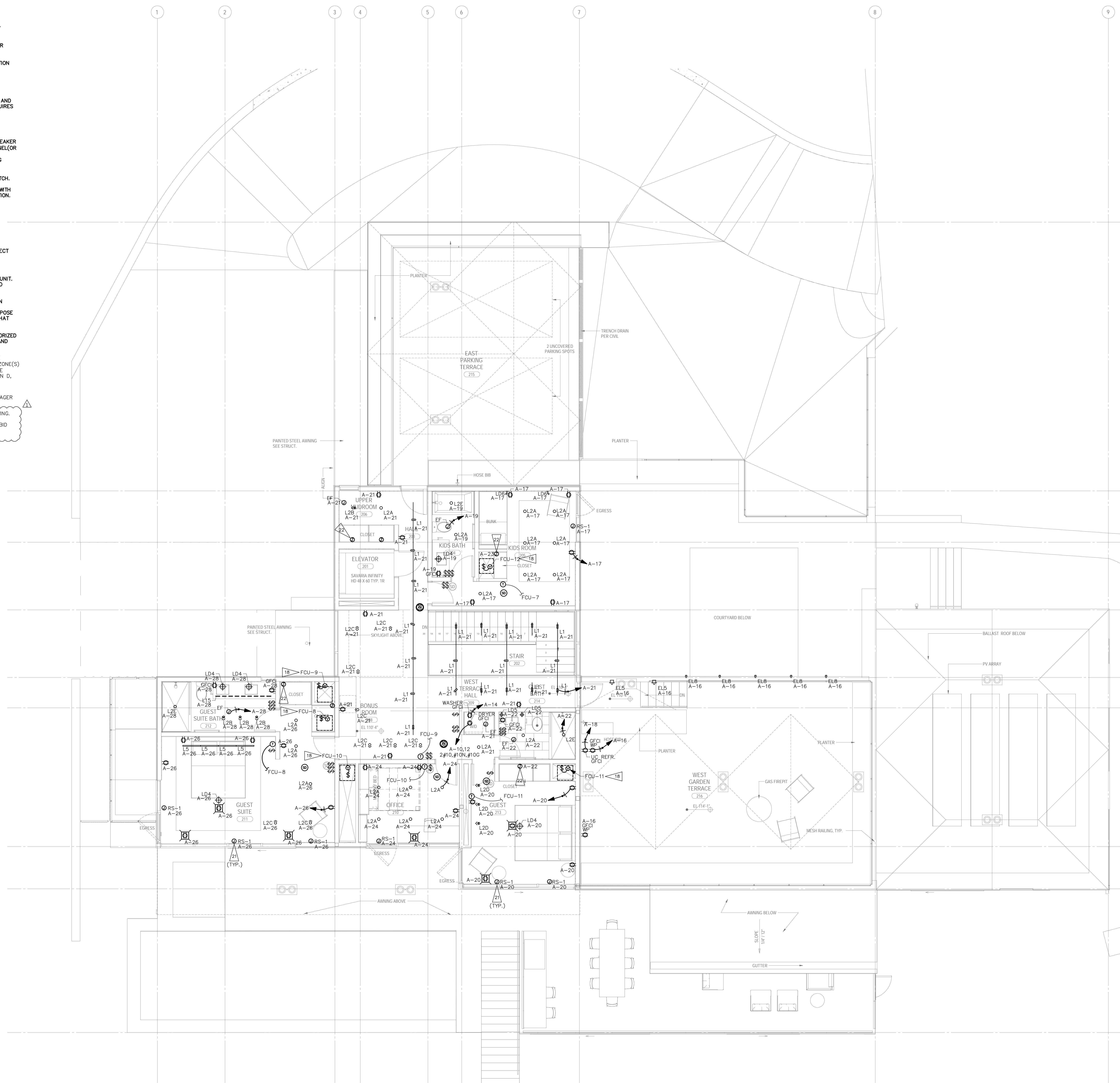

UPPER LEVEL FLOOR
ELECTRICAL PLAN
 SCALE: 1/4" = 1'-0"



02/23/24

project architect: JMN
 project manager: JMN
 drawn by: HDA
 checked by: PR
 job no.: 1316-001

no.	date	description

NOT FOR CONSTRUCTION
 PERMIT SET

09/08/2023
 title: ELECTRICAL FLOOR PLANS

sheet:
E2.02

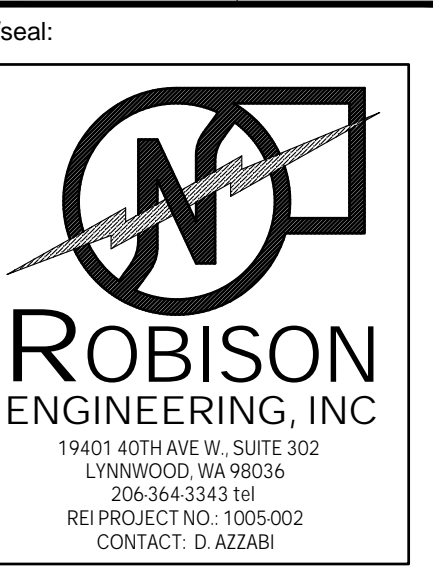

02/23/24

(TWO SECTIONAL PANEL)

Panel	ROOM	VOLTS	240/120V 2P 3W	AIC	42,000		
MOUNTING SURFACE	BUS AMPS	600	MAIN BKR	MLO			
FED FROM	CT-MAIN	NEUTRAL	100%	LUGS	STANDARD		
NOTE: INTEGRAL SURGE PROTECTION							
CKT #	BKR	LOAD KVA	CIRCUIT DESCRIPTION	CKT #	BKR	LOAD KVA	CIRCUIT DESCRIPTION
1	200/2	29.4	PANEL B	2	100/2	7.55	PANEL P2
3	100/2	17.1	PANEL P1	4	60/2	11	L2 HP-1
7	60/2	11	L2 HP-2	8	30/2	4.95	L2 DRYER
11	60/2	11	L2 HP-3	12	20/1	1.5	L2 WASHER
15	20/1	1.08	L2 KIDS RM LIGHTING, RECEPT, RS-1	16	20/1	0.558	L2 WEST TERRACE EX FAN, LIGHTING, RECEPT
17	20/1	0.322	L2 KIDS BATHRM EX FAN, LIGHTING, RECEPT	18	20/1	0.6	L2 WEST TERRACE UC REFRIG
19	20/1	1.7	L2 MUDRM/HALL/BONUSRM EX FAN, LIGHTING, RECEPT	20	20/1	0.876	L2 GUEST RM LIGHTING, RECEPT, RS-1
21	50/2	7.7	L1 GARAGE EV CHARGER	22	20/1	0.348	L2 GUEST BATHRM EX FAN, LIGHTING, RECEPT
23	20/1	1.61	L1 LAUNDRY DRYER	24	20/1	0.854	L2 OFFICE LIGHTING, RECEPT, RS-1
25	30/2	4.95	L1 LAUNDRY DRYER	26	20/1	1.73	L2 GUEST SUITE LIGHTING, RECEPT, RS-1
27	20/1	3.4	L1 WEST TERRACE INFRARED HEATER	28	20/1	0.564	L2 GUEST SUITE BATH EX FAN, LIGHTING, RECEPT
29	20/2	3.4	L1 WEST TERRACE INFRARED HEATER	30	50/2	7.7	L1 GARAGE EV CHARGER
31	20/2	3.4	L1 WEST TERRACE INFRARED HEATER	32	30/2	4.95	L1 LAUNDRY DRYER
33	20/2	3.4	L1 WEST TERRACE INFRARED HEATER	34	20/1	3.2	L1 WEST TERRACE INFRARED HEATER
35	20/1	1.5	L1 LAUNDRY WASHER	38	20/2	3.4	L1 WEST TERRACE INFRARED HEATER
37	20/1	1.5	L1 LAUNDRY SMALL APPLIANCE	40	30/2	4.5	L1 KITCH STEAM OVEN
39	20/1	1.43	L1 HALL/LAUNDRY/MUD EX FAN, LIGHTING, RECEPT	42	20/1	1.5	L1 LAUNDRY WASHER
41	20/1	1.5	L1 GARAGE DOOR OPENER	44	20/1	1.68	L1 MUD/ENTRY/HALL EX FAN, LIGHTING, RECEPT
43	20/1	1.5	L1 GARAGE DOOR OPENER	46	20/1	1.77	L1 MEDIA RM FLATSCREEN, LIGHTING, RECEPT, RS-1
45	20/1	0.36	L1 GARAGE IRRIG CONTR	48	20/1	1.77	L1 MEDIA RM FLATSCREEN, LIGHTING, RECEPT, RS-1
47	20/1	1.25	L1 WEST TERRACE FAN, LIGHTING, RECEPT	50	20/1	1.12	L1 ZUKA PATIO/NERIOR CRTYARD LIGHTING, RECEPT
49	20/1	0.844	L1 EXTERIOR LIGHTING, RECEPT	52	20/1	1.78	L1 GARAGE LIGHTING, RECEPT
51	20/1	0.5	L1 MEDIA RM A/V CABINET	54	20/1	1.83	L1 PRIMARY BEDRM LIGHTING, RECEPT, RS-1
53	20/1	0.36	L1 MEDIA RM SMART BOX	56	20/1	1.5	L1 KITCH DISHWASHER
55	20/1	1.8	L1 KITCH FREEZER	58	20/1	0.8	L1 KITCH DISPOSAL
57	20/1	0.8	L1 KITCH REFRIG	60	20/1	1.5	L1 KITCH MICROWAVE
59	20/1	1.5	L1 KITCH GAS RANGE, HOOD	62	20/1	1.5	L1 KITCH SMALL APPLIANCE
61	20/1	1.11	L1 KITCH LIGHT, LIGHTING, RECEPT, RS-1	64	20/1	1.5	L1 KITCH SMALL APPLIANCE
63	20/1	1.53	L1 LIVING FIREPLACE, FLATSCREEN, LIGHTING, RECEPT, RS-1	66	20/1	1.5	L1 KITCH SMALL APPLIANCE
65	20/1	0.462	L1 POOL BATH/SHOWER EX FAN, LIGHTING, RECEPT	68	20/1	1.83	L1 PRIMARY BEDRM LIGHTING, RECEPT, RS-1
67	20/2	2.9	EX FOND PUMP	70	20/1	0.5	L1 PRIMARY WC LIGHTING, RECEPT
69	20/2	2.9	EX FOND PUMP	72	20/1	0.816	L1 PRIMARY BATH EX FAN, LIGHTING, RECEPT, RS-1
71	20/1	1.5	EX DOCK POWERWASH	74	20/1	0.4	EX LANDSCAPEZ LTG
73	20/1	0.5	EX DOCK LTG	76	20/1	0.4	EX LANDSCAPEZ LTG
75	20/1	0	SPARE	78	20/1	0	SPARE
77	20/1	0	SPARE	80	20/1	0	SPARE
79	20/1	0	SPARE	82	20/1	0	SPARE
81	20/1	0	SPARE	84	20/1	0	FUTURE PV
83	20/1	0	SPARE				

CONN KVA	CALC KVA	(35%>3, 25%>120)	(3 VA/SP)	CONN KVA	CALC KVA	(100%)
42.1	16.7			4.5	3.6	
DWELLING UNIT LIGHTING	31.8	10.522	9			
DWELLING UNIT SMALL-APPLIANCE & LAUNDRY	4.5	0.194	(125%)	14.9	14.9	(100%)
APPLIANCE	68.9	51.7	(75%)	1.1	2.76	(25%)
				6.72	6.72	(100%)
				0.9	0.9	(50%>10)
				0.5	0.5	(100%)
				43.3	43.3	(100%)
				33.1	0	(0%)
				141		
				588 A		
				93.3		
				101%		

(LOWER LEVEL PANEL)

Panel	ROOM	VOLTS	240/120V 2P 3W	AIC	42,000		
MOUNTING SURFACE	BUS AMPS	200	MAIN BKR	MLO			
FED FROM	A	NEUTRAL	100%	LUGS	STANDARD		
NOTE: INTEGRAL SURGE PROTECTION							
CKT #	BKR	LOAD KVA	CIRCUIT DESCRIPTION	CKT #	BKR	LOAD KVA	CIRCUIT DESCRIPTION
1	30/2	5	B1 WH-1	2	50/2	11.5	B1 KLUN
3	30/2	5	B1 WH-2	4	20/1	1.22	B1 MECH STORAGE LIGHTING, RECEPT
7	1	0	B1 JUDY'S STUDIO LIGHTING, RECEPT	8	20/1	0.646	B1 MECH STORAGE/HALL CO/SD, LIGHTING, RECEPT
9	20/1	1.1	B1 JUDY'S STUDIO LIGHTING, RECEPT	10	15/1	0.1	B1 DOAS-1
11	20/1	0.376	B1 BASE BATH EX FAN, LIGHTING, RECEPT	12	20/1	1.51	B1 PLAY ROOM LIGHTING, RECEPT
13	20/1	0.3	B1 KLUN RM EX FAN, LIGHTING, RECEPT	14	20/1	0.815	B1 STORAGE LIGHTING, RECEPT
15	20/1	1.61	B1 GYM EX FAN, FLATSCREEN, LIGHTING, RECEPT	16	20/1	0.24	B1 EXT LIGHTING, RECEPT
17	20/1	0	SPARE	18	20/1	0	SPARE
19	20/1	0	SPARE	20	20/1	0	SPARE
21	20/1	0	SPARE	22	20/1	0	SPARE
23	20/1	0	SPARE	24	20/1	0	SPARE

CONN KVA	CALC KVA	(35%>3, 25%>120)	APPLIANCE LARGEST MOTOR	CONN KVA	CALC KVA	(75%)
15.8	7.47		21.6	16.2		
DWELLING UNIT LIGHTING	15.8	5.261 SF	0.1	0.025		(25%)
DWELLING UNIT LIGHTING	0.155	0.194	0.9	0.9		(50%>10)
				24.8		
				103 A		
				97.1%		
				103%		

(POOL)

Panel	ROOM	VOLTS	240/120V 2P 3W	AIC	42,000		
MOUNTING SURFACE	BUS AMPS	100	MAIN BKR	MLO			
FED FROM	A	NEUTRAL	100%	LUGS	STANDARD		
NOTE: INTEGRAL SURGE PROTECTION							
CKT #	BKR	LOAD KVA	CIRCUIT DESCRIPTION	CKT #	BKR	LOAD KVA	CIRCUIT DESCRIPTION
1	50/2	10.4	SELF CONTAINED HOT TUB	2	20/2	1	CHLORINATOR
3	20/2	2.88	POOL PUMP	4	20/2	1.32	LP/NG POOL HEATER
5	20/1	0.1	POOL LTG	6	20/1	0.16	CRAWL SPACE EX FAN
9	20/1	1.26	POOL/SPA MECH RM EX FAN, LIGHTING, RECEPT	8	20/1	0	SPARE
11	20/1	0	SPARE	14	20/1	0	SPARE
13	20/1	0	SPARE	16	20/1	0	SPARE
15	20/1	0	SPARE	18	20/1	0	SPARE
17	20/1	0	SPARE	20	20/1	0	SPARE
19	20/1	0	SPARE	22	20/1	0	SPARE
21	20/1	0	SPARE	24	20/1	0	SPARE
23	20/1	0	SPARE				

CONN KVA	CALC KVA	(75%)	TOTAL LOAD	CONN KVA	CALC KVA
15.8	11.8		12.5		
APPLIANCE	2.88	0.72	52.3 A		
LARGEST MOTOR			94.3%		
			108%		

(ELEVATOR)

Panel	ROOM	VOLTS	240/120V 2P 3W	AIC	42,000		
MOUNTING SURFACE	BUS AMPS	100	MAIN BKR	MLO			
FED FROM	A	NEUTRAL	100%	LUGS	STANDARD		
NOTE: INTEGRAL SURGE PROTECTION							
CKT #	BKR	LOAD KVA	CIRCUIT DESCRIPTION	CKT #	BKR	LOAD KVA	CIRCUIT DESCRIPTION
1	30/2	6.72	ELEV	2	20/1	0.25	CAR EX FAN
3	20/1	0	SPARE	4	20/1	0.18	ELEV RECEPT
5	20/1	0	SPARE	6	20/1	0.4	CAR LTG
7	20/1	0	SPARE	8	20/1	0	SPARE
9	20/1	0	SPARE	10	20/1	0	SPARE
11	20/1	0	SPARE	12	20/1	0	SPARE

CONN KVA	CALC KVA	(25%)	MOTORS	CONN KVA	CALC KVA	(100%)
6.72	1.68		6.72	6.72		
LARGEST MOTOR				8.4		
				35 A		
				100%		
				93.8%		

FUSED LUMINAIRE SCHEDULE

CALLOUT	SYMBOL	DESCRIPTION	TOTAL VA	VOLTS	NOTE 1
EL1	o	EXTERIOR WET LISTED CANOPY LIGHT	14	120V 1P 2W	
EL2	o	EXTERIOR RECESSED DOWNLIGHT	14	120V 1P 2W	
EL3	+	EXTERIOR SCONCE	20	120V 1P 2W	
EL5	+	EXTERIOR WALL RECESSED STEP LIGHT	14	120V 1P 2W	
EL6	-	EXTERIOR STEP LIGHT	14	120V 1P 2W	
EL7	+	IN-GRADE COURTYARD LIGHT	14	120V 1P 2W	
EL8	+	HANDRAIL STANCHION LIGHT	14	120V 1P 2W	
L1	o	LV TRACK MOUNTED MONOPOINT (W/VARIABLE OPTICS)	14	120V 1P 2W	
L2A	o	FIXED DOWNLIGHT	14	120V 1P 2W	
L2B	o	ADJUSTABLE DOWNLIGHT NARROW DISTRIBUTION	14	120V 1P 2W	
L2C	o	ADJUSTABLE DOWNLIGHT WIDE DISTRIBUTION	14	120V 1P 2W	
L2D	o	WALL WASH	14	120V 1P 2W	
L2E	o	WET LOCATION LISTED	14	120V 1P 2W	
L3	+	UPLIGHT ON CANOPY	20	120V 1P 2W	
L4A	o	DOWNLIGHT+ADJUSTABLE MONOPOINT NARROW DIST	14	120V 1P 2W	
L4B	o	DOWNLIGHT+ADJUSTABLE MONOPOINT WIDE DIST.	14	120V 1P 2W	
L5	-	HIGH EFFICIENCY STRIP LIGHT IN COVE/NICHE	14	120V 1P 2W	
L6	o	FIXED DOWNLIGHT	14	120V 1P 2W	
L7	-	BACK OF HOUSE STRIPLIGHT	20	120V 1P 2W	
L8	+	LV TRACK MOUNTED SMALL MONOPOINT (W/VARIABLE OPTICS)	14	120V 1P 2W	
L9	-	UNDERCOUNTER LIGHT IN KITCHEN	20	120V 1P 2W	
L10	-	LINEAR LED NIGHT LIGHT	14	120V 1P 2W	
L11	+	BEDSIDE READING LIGHT	14	120V 1P 2W	
L12	+	BEDSIDE SCONCE	20	120V 1P 2W	
L13	-	CASEWORK LIGHT	14	120V 1P 2W	
L14	+	MASTER BATH VANITY LIGHT	20	120V 1P 2W	
L15	-	BATH NIGHT LIGHT AT CASEWORK	20	120V 1P 2W	
L16	-	LINEAR LED CLOSED LIGHT	20	120V 1P 2W	
L17	+	FLUSH MOUNT JELLY JAR LIGHT	14	120V 1P 2W	
L19	-	LOW VOLTAGE TRACK (BUSWAY) MOUNTED	5.8	120V 1P 2W	TBD
LD1	+	DECORATIVE FLUSH MOUNT IN MASTER BEDROOM	14	120V 1P 2W	
LD2	+	SCONCE POWDER ROOM	20	120V 1P 2W	
LD3	+	DECORATIVE PENDANT FLUSH MOUNT IN BEDROOM	20	120V 1P 2W	
LD4	+	BATHROOM VANITY PENDANT	14	120V 1P 2W	
LD5	+	SCONCE SHARED BATHROOM	20	120V 1P 2W	
LD6	+	KIDS NIGHT/READING LIGHT	14	120V 1P 2W	

NOT ALL USED
 CONFIRM FINAL MODEL/MAKE & QUANTITY PRIOR TO ORDERING

CT-MAIN

ROOM	MOUNTING SURFACE	FED FROM	VOLTS	240/120V 2P 3W	BUS AMPS	600	NEUTRAL	100%	AIC	4
------	------------------	----------	-------	----------------	----------	-----	---------	------	-----	---